

MhouseKit

CE 0682

WS200S

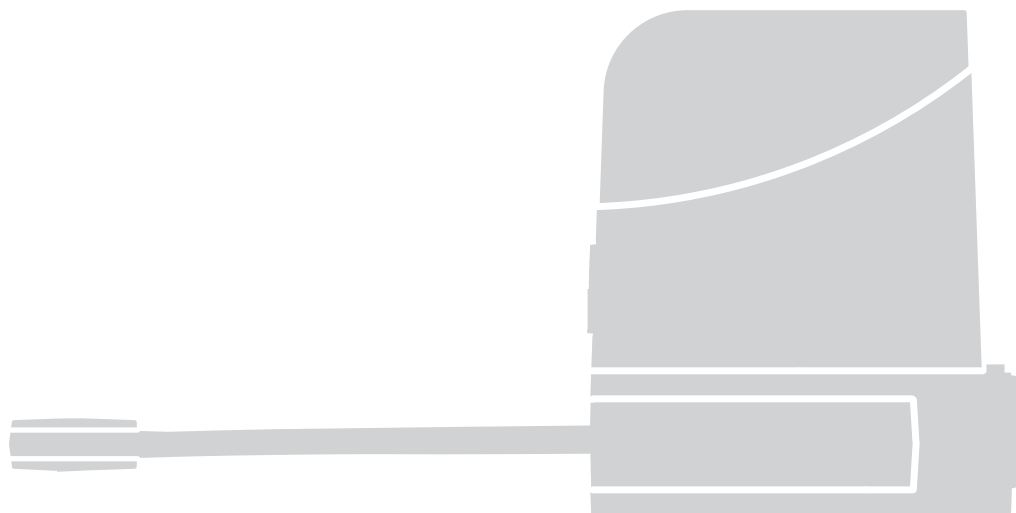

Kit complet pour automatiser un portail battant

FR - Instructions et avertissements pour l'installation et l'utilisation

EN - Instructions and warnings for installation and use

IT - Istruzioni ed avvertenze per l'installazione e l'uso

PL - Instrukcje i ostrzeżenia do instalacji i użytkowania

Nice

Easy For You

— STEP 1 —

Safety warnings

- **WARNING! – This manual contains important safety instructions and warnings.** Incorrect installation could lead to serious injury. Before starting, please read all sections of the manual carefully. If in any doubt, suspend installation and call the Nice Support Service for clarification.
- **WARNING! – Important instructions: please retain this manual for any future maintenance work and product disposal.**
- **WARNING! – According to the most recent legislation, the installation of an automatic door or gate must be in full observance of the standards envisaged by European Directive 2006/42/EC (Machinery Directive) and in particular standards EN 12445; EN 12453; EN 12635 and EN 13241-1, which enable declaration of presumed conformity of the automation. Taking this into account, all connection to electricity grid, test, commissioning and maintenance operations on the product must be performed exclusively by a qualified and skilled technician!**
However, all preliminary set-up, installation, connection of devices to one another, and programming operations may be performed by personnel with standard skills, provided that all instructions and the relative sequences in this manual are strictly observed, with special reference to the warnings in STEP 1.

– Installation warnings

While reading this manual, take care to observe all instructions marked with the following symbol:



These symbols indicate subjects that may be the source of potential hazards and therefore the prescribed operations **must be performed exclusively by qualified and skilled personnel**, in observance of these instructions and current safety standards.

- Before commencing the installation, check that this product is suitable for controlling your gate or doorway (see STEP 3 and the “Product technical specifications” chapter). If it is not suitable, DO NOT continue with the installation.
- Provide a disconnection device (not supplied) in the plant’s power supply grid, with a contact opening distance that permits complete disconnection under the conditions dictated by overvoltage category III.
- **All installation and maintenance work must be carried out with the automation system disconnected from the electricity supply.** If the power disconnection device cannot be seen from where the automation system is positioned, then before starting work a notice must be attached to the disconnection device bearing the words “CAUTION! MAINTENANCE IN PROGRESS”.
- **WARNING! - Turning on the power supply to the motor before you have completed its installation on the gate pillar and leaf is strictly prohibited.**
- Handle the product with care during installation, taking care to avoid crushing, denting or dropping it, or contact with liquids of any kind. Keep the product away from sources of heat and naked flames. Failure to observe the above can damage the product, and increase the risk of danger or malfunction. Should this occur, suspend installation work

- immediately and contact the Nice Support Service.
- Do not modify any part of the product. Operations other than as specified can only cause malfunctions. The manufacturer declines all liability for damage caused by makeshift modifications to the product.
- If the power supply cable is damaged, it must be replaced only by a qualified and skilled technician, so as to prevent any risk.
- Connect the control unit to an electric power line equipped with an earthing system.
- The product is not intended for use by persons, including children, with limited physical, sensory or mental capacities, or who lack experience or knowledge, unless supervised or trained in the use of the product by a person responsible for their safety.
- The key selector must be positioned within view of the automation mechanism, far away from its moving parts, at a minimum height of 1.5 m from the ground and in a location which is not accessible to the public. If it is used in “manned” mode, make sure there are no people in the vicinity of the automation mechanism.
- Any children near the automation system must be kept under supervision to ensure that they do not play with it.
- Check that there are no points where people could become trapped or crushed against fixed parts when the gate is fully open or fully closed; if there are, provide protection for these parts.
- The product may not be considered a complete anti-intrusion protection system. If you wish to have effective protection, combine the automation mechanism with other security devices.
- The automation mechanism cannot be used before it has been commissioned as specified in the chapter on “Testing and commissioning”.
- Inspect the automation mechanism frequently to check for unbalancing, signs of wear or damage to electrical cables and mechanical parts. Do not use the automation mechanism if adjustment or repair is required.
- If it is not used for a long time, remove the optional battery (PR1) and keep it in a dry place to make sure it does not leak harmful substances.
- Do not allow children to play with the fixed control devices. Keep remote control devices out of their reach as well.
- The packing materials of the product must be disposed of in compliance with local regulations.

Operation warnings

- Clean the surfaces of the product with a soft, slightly damp cloth. Use only water; do not use cleaning products or solvents.

KNOWLEDGE OF THE PRODUCT AND PREPARATION FOR INSTALLATION

NOTE TO MANUAL

- This manual describes how to implement a complete and optimal automation, like that shown in fig. 1, using all the Mhouse devices which form part of the automation system known as “WS200S”. Some of these devices are optional and may not be present in this kit. For a complete overview of the devices, see the Mhouse product catalogue.
- This manual is designed as a step-by-step guide. Therefore, for the safety and ease of assembly and programming work, we advice you to carry out all the operations described in the same order in which they are presented.

— STEP 2 —

2.1 - PRODUCT DESCRIPTION AND INTENDED USE

The devices in this kit, plus other accessories (some optional and some not included), together form the automation system called “WS200S”, designed for automation of a hinged gate for “residential” use. **All uses other than the intended use described and use in environmental conditions other than those described in this manual should be considered improper and forbidden!**

The main automation component is made up of an electromechanical gearmotor, provided with a 24 V direct current motor and a reduction unit with worm screws; it is equipped with a mechanical release and key which allows you to manually move the gate in the event of a lack of power supply. The gearmotor is equipped with a command control unit that manages the operation of all of the automation. The command control

unit is made up of an electronic board and an integrated radio receiver, to receive commands sent by the user via the transmitter. It can memorise up to 256 GTX4 transmitters (if these are memorised in "Mode I") and up to 6 PH100 photocell pairs. Connection of the control unit to the various devices takes place via a single cable with two electrical conductors ("ECSbus" system). Furthermore, the control unit can be powered by a fixed electrical network (230 V) or, alternatively, by the Mhouse PF solar power system. If powered from the grid, it can host a buffer battery (mod. PR1, optional accessory) which ensures that the automation can execute certain manoeuvres, during the hours following a loss of power (electrical black-out). During the black-out, or at any other time, it is possible to move the gate manually also, by first releasing the gearmotor using the appropriate key (see chapter 11.3 - Usage guide).

2.2 - DEVICES REQUIRED TO CREATE A FULL SYSTEM

The **fig. 2** shows all the devices required to create a full system, such as that shown in **fig. 1**. The devices are:

- A** - 2 electromechanical WS100SK gearmotors, complete with mounting brackets
- B** - 3 release keys
- C** - 1 pair of PH100 photocells (made up of a TX and an RX)
- D** - 2 GTX4 radio transmitters
- E** - 1 FL100 flashing indicator with built-in antenna
- F** - Brackets for fixing and curved anti-shear arms: the screws needed to fasten the slotted arms are not provided, because they vary according to the material and thickness of the doors.
- G** - Metal hardware

Note - Some devices and accessories mentioned in this manual are optional and may not be present in the kit. For a complete overview, see the Mhouse product catalogue or visit www.niceforyou.com.

— STEP 3 —

3.1 - CHECK SUITABILITY OF GATE TO BE AUTOMATED AND OF THE ENVIRONMENT

- Ensure that the mechanical structure of the gate is suitable for automation and complies with local standards. To verify this, refer to the technical data on the label of the gate. **Important** - This product cannot automate a gate that is not already secure and efficient; moreover, it cannot resolve defects caused by improper installation of the gate or from its poor maintenance.
- Manually move the gate leaf in both directions (open/closed) and make sure that the movement takes place with a constant friction at every point in its course (there should be no points that require more effort nor less).
- If there is an access door in the gate, or within the range of movement of the gate, make sure that it does not obstruct normal travel and, if necessary, provide an appropriate interlock system.
- Manually bring the door of the gate into any position; then, leave it closed and make sure that it does not move.
- Ensure that the environment in which the gearmotor is to be installed has sufficient space to be able to perform the manual manoeuvre of releasing the gearmotor.
- Make sure that the surfaces selected for the installation of the devices, are strong and can ensure a stable attachment; for the photocells, choose a flat surface that can ensure a correct alignment of the pair (Tx and Rx).
- Ensure that all devices to be installed are in a sheltered location and protected against the risk of accidental impact.

3.2 - PRODUCT APPLICATION LIMITS

Before proceeding with installation perform the following checks in the suggested order and check their compliance with both the data in this paragraph and the technical data in the chapter "Product technical specifications":

- 1 - Check that the gate leaf has dimensions and weight which fall within the following limits:
 - maximum length **2.2 m**
 - maximum weight **150 kg**
 - opening angle **110°**
- 2 - Check that the maximum and minimum temperatures of the installation environments are within the temperature limits specified for operating this product. Refer to the technical data contained in the chapter "Product technical specifications".
- 3 - Taking into account the direction from which the (pre-existing) electric line which is to power the product originates, decide to which leaf you intend to affix the gearmotor with the Control unit.

- 4 - Check, on each leaf and on the wall (or pillar) adjacent, that there is enough space to attach the gearmotor, referring to the values indicated in **fig. 3-4-6-7** and to the following notes:

- a) Fig. 3:** shows the measurements of the total size of the gearmotor.
 - b) Fig. 4:** shows the horizontal space in which the rear support of the gearmotor is to be placed. The exact location in which to place the support must be calculated by referring to point O2 of STEP 5.
 - c) Fig. 6:** shows the maximum distance required "B" between the leaf pivot point and the wall surface to which the rear support of the gearmotor will be attached.
 - d) Fig. 7:** shows the minimum distance required "E" (400 mm) between the gearmotor arm and any possible obstacle in the vicinity (wall, flowerbed edging, etc.) when the leaf is fully open.
- Note – This measurement must be taken starting from the centreline of the gearmotor.*

3.3 - PRODUCT DURABILITY

Durability is the average economic life span of the product. The value of the life span is strongly influenced by the intensity of the manoeuvres, i.e. the sum of all factors that contribute to product wear, see Table 1. To estimate the life span of your automated device, proceed as follows:

- 01.** Add up all the values of the entries in **Table 1**;
- 02.** In **Graph 1**, from the value obtained above, trace a vertical line until it intersects the curve; from this point trace a horizontal line until it intersects the line of the "manoeuvre cycles". The obtained value is the estimated life span of your product.

The lifetime values specified in the graph are only obtainable if the maintenance schedule is strictly observed. See chapter 9 - Maintenance schedule. The estimation of durability is made on the basis of design calculations and the results of tests performed on prototypes. As it is only an estimation, it does not represent any form of guarantee on the effective life span of the product.

		Severity index %
Leaf length m	1 - 1.5 m	10%
	1.5 - 2.2 m	25%
Leaf weight Kg	< 80 kg	10%
	80 - 150 kg	25%
Surrounding temperature greater than 40°C or lower than 0°C or humidity greater than 80%		20%
Solid leaf		15%
Installation in suction cup area		15%

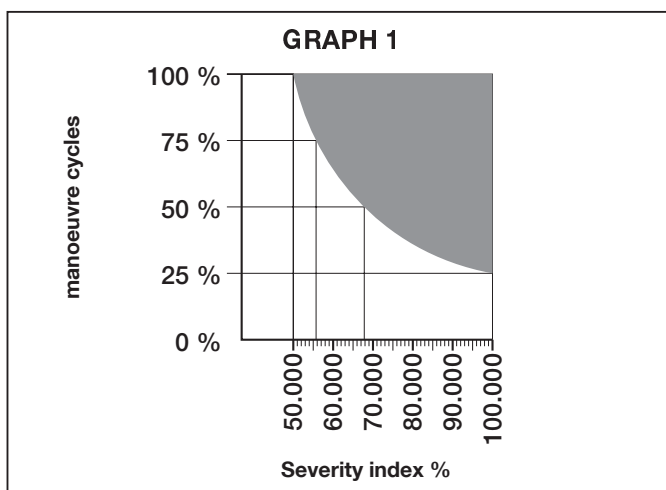

Example of durability calculation: automation of a gate with a door 1.8m long with a weight of 100 kg, installed in a windy area. Table 1 shows the "severity index" for this type of installation: 25% ("Door length"), 10% ("Door weight") and 15% ("Installation in windy area"). These indicators must be added together to obtain the overall severity index, which is in this case 50%. With the value identified (50%), look at the vertical axis of Graph 1 ("severity index"), and identify the value corresponding to the number of "manoeuvre cycles" our product will be able to perform in its life span, about 72,000 cycles.

— STEP 4 —

4.1 - WORKS PRIOR TO INSTALLATION

4.1.1 - Establish the position of the devices in the system

With reference to **fig. 1** and **fig. 5**, locate the approximate position for installation of each device envisaged in the system. The **fig. 1** shows a system built with this product plus other optional accessories from the Mhouse line. The various elements are positioned according to a standard and usual layout. The devices used are:

- [a] - 1 FL100 flashing indicator with built-in antenna
- [b] - 1 pair of PH100 photocells (made up of a TX and an RX)
- [c] - 1 KS100 Key-operated selector switch
- [d] - 2 photocells columns
- [e] - WS100SK gearmotor with incorporated CL7SKA control unit
- [f] - WS100SK gearmotor
- [g] - Closure stop (not supplied)

WARNING! - Some of these devices are optional and may not be present in this package (see the Mhouse product catalogue).

WARNINGS:

- The gearmotors must be affixed to the column/wall, laterally to the respective gate leaves;
- Fixed type control devices must be positioned:
 - in view of the automation;
 - away from its moving parts;
 - at a minimum height of 1.5 m from the floor/ground;
 - not accessible to strangers.

4.1.2 - Establish the position of all the connecting cables

Refer to the instructions in section 4.2 to determine the space in which to dig the routes for the cable ducts for the electrical cables.

4.1.3 - Obtain the tools and materials required for the work

Before beginning work, make sure you have all the tools and materials required to carry out the work. Make sure that these are in good condition and comply with local safety regulations.

4.1.4 - Carry out the preparatory works

Prepare the environment for the subsequent installation of the devices, carrying out preliminary work such as, for example:

- excavation of routes for the cable ducting for the electrical cables (alternatively, external raceways may be used);
- installation of the cable ducting and their attachment in the concrete;
- sizing of all electrical cables to the desired length (see section 4.2) and their passage in the ducting.

Caution! - At this stage do not implement any type of electrical connection.

Warnings:

- Ducting and raceways are used to protect the electrical cables from damage due to accidental impacts.
- When laying the ducting, also take into account that due to possible deposits of water in the routing ducts, the ducting might create condensation in the control unit, with consequent damage to the electronic circuits.
- Place the ends of the ducting in the vicinity of the points provided for affixing the devices.

4.2 - ELECTRICAL CABLES PREPARATION

To prepare all connection cables, proceed as follows.

- a) - Observe **fig. 5** to understand how the various devices should be connected to the control unit and the terminals to be used for each connection. **Important** - Only devices which support "ECSbus" technology can be connected to the "ECSbus" terminal.
- b) - Observe **fig. 1** to understand how to position the electrical cables in the environment. Then, draw a similar diagram on paper, adapting it to the specific needs of your system. **Note** - This diagram will be useful, both to guide the excavation of the routes for the cable ducting, and for drawing up a complete list of the cables required.
- c) - Read **Table 2** to determine the type of cables to use; then use the diagram you just drew and the environmental measurements to determine the length of each individual cable. **Caution! - Each cable must not exceed the maximum length indicated in Table 2.**

WARNING - The "ECSbus" technology allows you to connect multiple devices together, using, between one device and the next, a single "bus" cable, with two internal electrical conductors. The connection between the devices can adopt a "cascade", a "star" or a "mixed" configuration, between the first two.

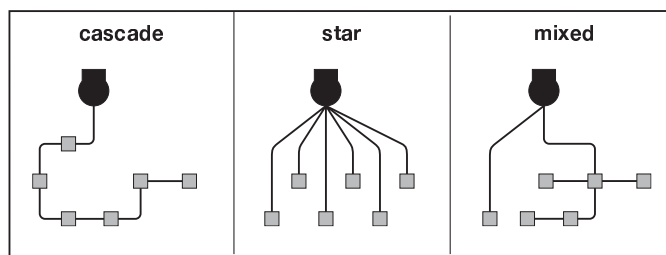

TABLE 2 – Technical specifications of electric cables

Connection	Cable type (minimum gauge values)	Maximum admissible length
A - Electric power line	Cable 3 x 1.5 mm ²	30 m (note 1)
B - FLASH flashing indicator output	Cable 2 x 1 mm ²	6 m
C - Antenna cable	RG58 type shielded cable	20m (less than 5m recommended)
D - ECSBus DEVICES cable	Cable 2 x 0.5 mm ²	20 m (note 2)
E - STOP input	Cable 2 x 0.5 mm ²	20 m (note 3)
F - OPEN input	Cable 2 x 0.5 mm ²	20 m (note 3)
G - GEARMOTOR POWER SUPPLY cable	Cable 3 x 1.5 mm ²	10m

Note 1 - A power supply cable longer than 30m may be used provided it has a larger gauge (3 x 2.5mm²), and that a safety earthing system is provided near the automation.

Note 2 - If the "ECSBus" cable is longer than 20m, up to 40m, a larger gauge (2 x 1mm²) cable is needed.

Note 3 - These two cables may be replaced by a single 4 x 0.5 mm² cable.

CAUTION! - The cables used must be suited to the type of environment of the installation site.

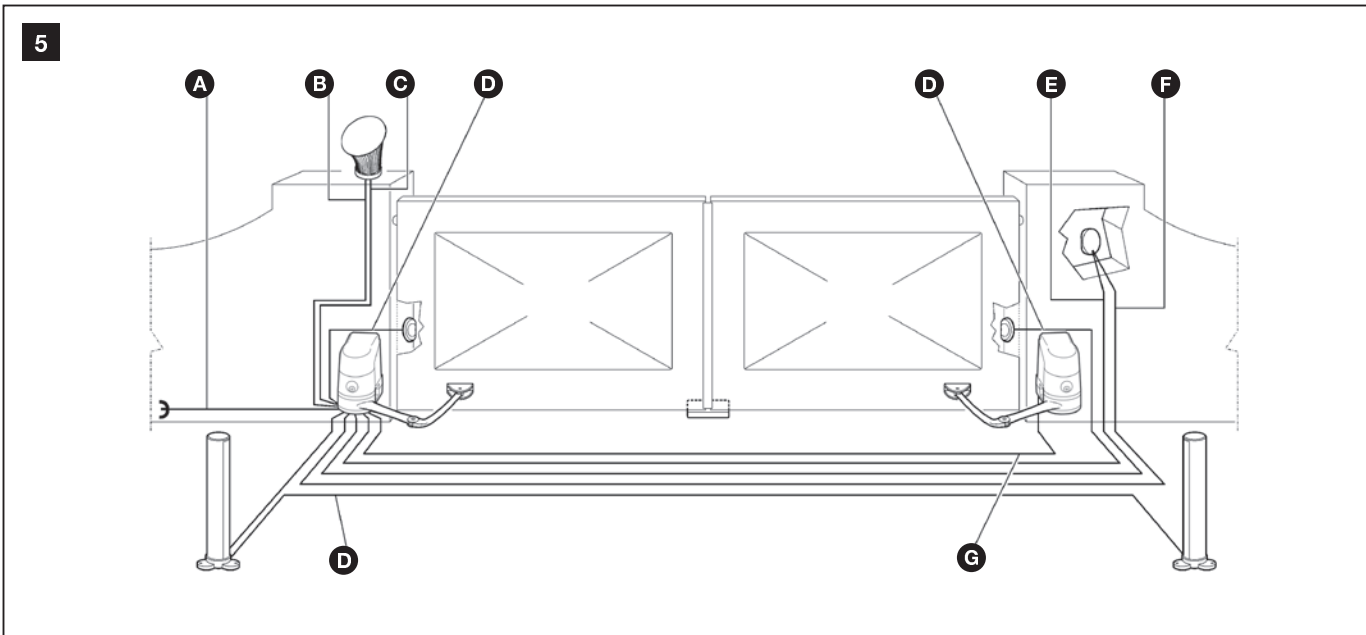
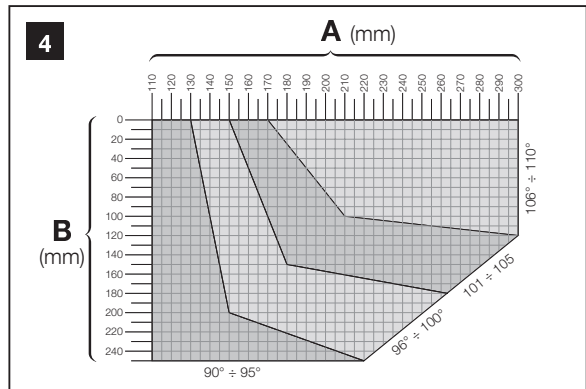
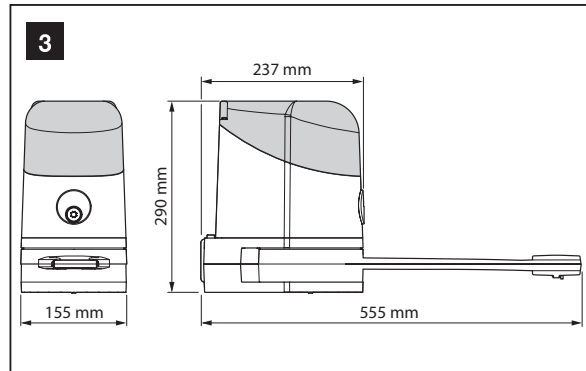
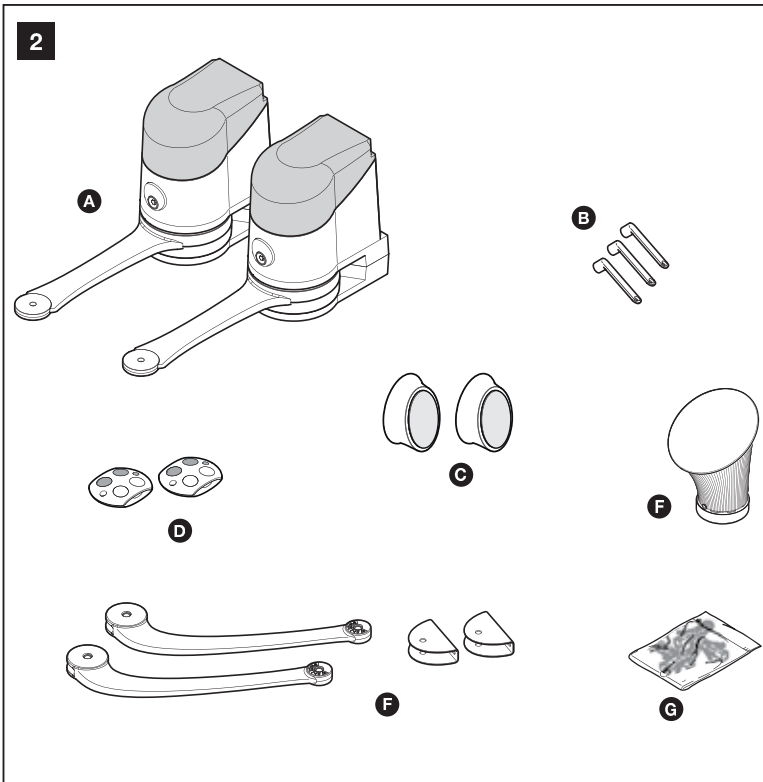
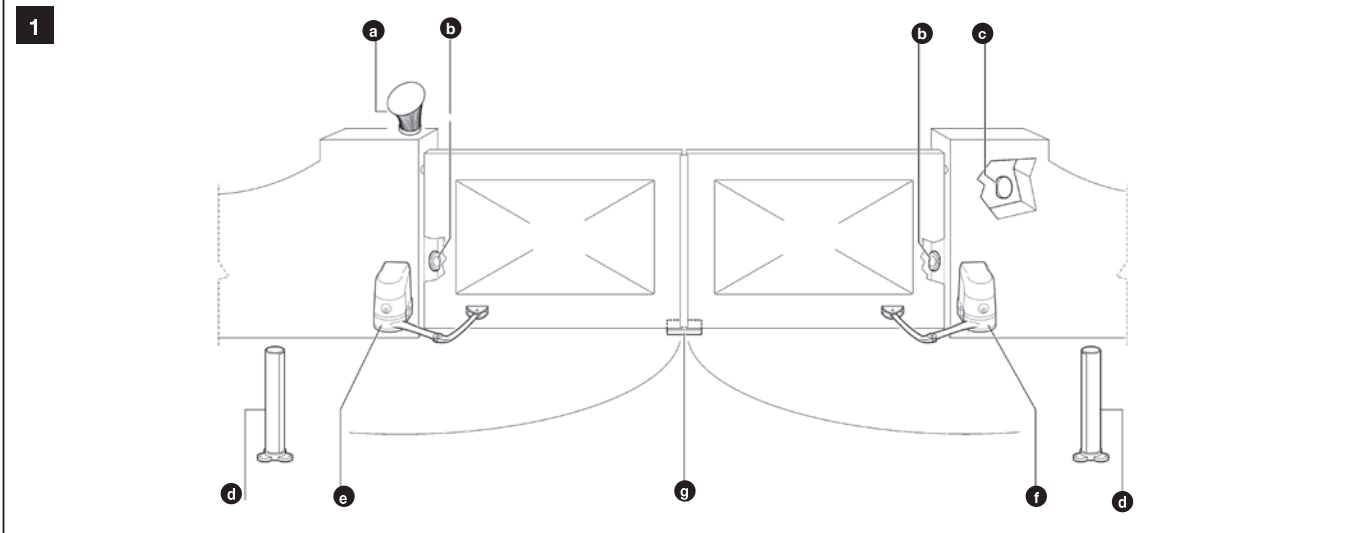

— STEP 5 —

IMPORTANT!

- The following assembly steps illustrate installation of the WS100SK/WS100SCK gearmotor.
 - For correct system operation it is necessary to supply mechanical stops, on the ground or wall, positioned at the maximum Opening and Closing points of the door. **Note** - These end stops are not included in the kit and do not form part of the Mhouse product range.

WARNINGS

- **Incorrect installation may cause serious physical injury to those working on or using the system.**
- **Before starting automation assembly, carry out the preliminary checks as described in STEP 3.**

5.1 - WS100SCK AND WS100SK GEARMOTOR INSTALLATION

01. Measure distance "B" (fig. 6).
02. Move the leaf to the desired maximum opening position, and check whether the angle value found falls within the values listed in **Graph 4**.
03. As shown in **fig. 4**, using value "B" and the opening angle, determine value "A". *Example: if "B" is 100mm and the angle required is equal to 100°, the distance "A" is around 180 mm.*
04. Affix the gearmotor mounting bracket to the wall, in a horizontal position, as shown in **fig. 8** and **9**. Use suitable anchors, screws and washers (not supplied).
05. Remove the mechanical stop located on the underside of the motor, using a 13mm wrench (**fig. 11**): loosen and unscrew the self-locking nut of the screw of the mechanical stop.
06. Insert the back of the gearmotor into the space provided on the mounting bracket, taking care to line up the holes on the motor with those on the bracket (**fig. 12**).
07. Support the gearmotor with one hand and with the other hand insert the two screws supplied into the holes. *Note – If the screws do not go in easily, use a hammer and a hex nut driver to insert them fully (see **fig. 13**). Then, fasten the screws with suitable nuts; to do this, use an Allen wrench to hold the head of the screw and a (10 mm) hex nut screwdriver, with external dimensions not exceeding 14.5 mm, to tighten the nut.*
08. Now, affix the curved arm to the gearmotor. **IMPORTANT!** – The arm must be positioned with the curvature pointing towards the gate leaf. Then align the holes on the two arms and insert the pin supplied and the ringed stop. (**fig. 14**).
09. To secure the attachment bracket to the gate leave, proceed in the following way:
 - a) Insert the bracket to the end of the curved arm, aligning the respective holes, and insert the pin supplied (without ring stop - **fig. 15**).
 - b) Release the gearmotor using the required key (refer to chapter "Manually releasing and locking the gearmotor" in the "Usage Guide").
 - c) Move the gate leaf into the fully closed position required, and extend the arm to its full length (**fig. 16**). Then, bring the latter to the leaf, until the mounting bracket is fully locked onto it.
 - d) Now, using a pencil, mark the drilling points and then drill the leaf using a drill. *Note – The screws required for leaf-fixture of the bracket are not included in the pack, as their type depends on the material and thickness of the gate or door in which they are inserted.*
10. Detach the bracket from the arm of the gearmotor, and affix it to the gate leaf. **Important** – Check that the bracket sits perfectly level.
11. Attach the gearmotor arm to the bracket by inserting the pin and the ring stop supplied.
12. **CAUTION!** – If, in your installation environment, there are no mechanical stops placed on the ground, refer to **STEP 5.2**.
13. Finally, still with the gearmotor released, manually move the two gate leaves into the position shown in **fig. 17** and lock the gearmotor using the appropriate key (refer to the chapter "Manually releasing and locking the gearmotor" found in the "TECHNICAL DOCUMENTATION" section). Now, using just a slight movement, move the gate leaf a few centimetres in the direction of full opening, until you hear a click.
14. **If the gate to be automated is a dual leaf type, repeat the same operations describe in this STEP 5 to also install the second gearmotor.**

5.2 - ADJUSTING THE OPENING MECHANICAL LIMIT SWITCH

If, in your installation environment, there are no mechanical stops placed

on the ground, designed to stop the wings of the gate at the end of their opening movement, it is necessary to adjust the mechanical stop on the bottom side of each motor, in the following manner:

01. With the gearmotor released, manually move the leaf to the Open position.
02. Locate the centrepoint (axis) of the gearmotor arm, and mark it using a piece of adhesive tape placed in the fixed part of the gearmotor, above the arm (**fig. 18**).
03. Now close the gate leaf.
04. In order to facilitate mounting the mechanical stop, we recommend that you add a piece of adhesive tape, up to the base of the gearmotor, as shown in **fig. 19**.
05. Place the mechanical stop in the following way: if you are working on the gearmotor that moves the left-hand leaf, the mechanical stop must be fixed to the left of the adhesive tape, adjacent to it; conversely, if you are working on the gearmotor on the right the mechanical stop should be attached to the right of the adhesive tape, adjacent to it (**fig. 20**). Then fasten it using its self-locking nut (**fig. 21**).
06. Now, by moving the gate leaf manually, check that the latter stops exactly at the desired maximum opening point. If this is not the case, move the mechanical stop by one or two "teeth"; then check the maximum opening position again.
07. Finally, with the gearmotor still released, manually move the gate leaf to around half its travel, and lock the gearmotor using the appropriate key (refer to chapter "Manually releasing and locking the gearmotor" in the "Usage Guide"). Now, using just a slight movement, move the gate leaf a few centimetres in the direction of full opening until you hear a click.

5.3 - WS100SCK AND WS100SK GEARMOTOR CONNECTION

CAUTION! – All electrical connections must be made while disconnected from the grid and disconnected from the backup battery (if any).

To make the electrical connections, remove the top cover of the gearmotor as shown in **fig. 23**.

- **WS100SCK:** thread the cable through the appropriate duct located on the back of the gearmotor, and make the electrical connections as shown in **fig. 24**, replace the cover.
- **WS100WCK:** thread the cables through the appropriate duct located on the back of the gearmotor, and make the electrical connections as shown in **fig. 22**, replace the cover.

Bearing in mind that:

01. To facilitate connection operations, you can remove the terminals. After having made the connections, insert the terminals back into their dedicated seats.

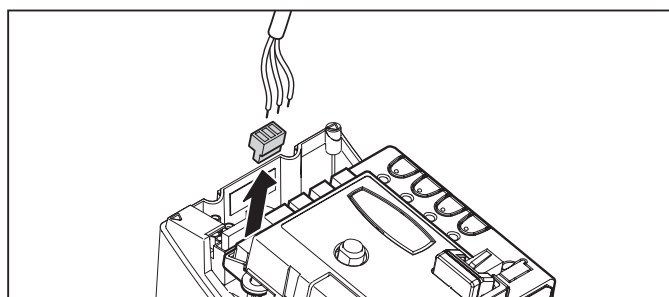

02. The WS100SK cable is connected as shown in detail (B) in **fig. 22**.
03. Remember that in order to avoid the risk of the two leaves colliding, the WS100WCK command unit first commands the motor connected to the M2 output to open, and then the motor connected to M1, whilst during closing, the reverse happens. Then, make sure that the (outer) terminal M1 is connected to the motor that drives the leaf resting on the mechanical stop, and terminal M2 to the top leaf.
 If you are using only one motor (gate with only one leaf), connect it to terminal M2, leaving terminal M1 free.
04. The grey terminals (open) and red (stop) of the KS100 key selector switch (optional accessory), are connected respectively to the grey terminals (open) and red (stop) of the control unit. You do not need to observe any polarity for the connection.
05. If you are using an external antenna (optional accessory), you will need to connect the control unit core and the screen of the shielded cable as shown in detail (A) in **fig. 22**.

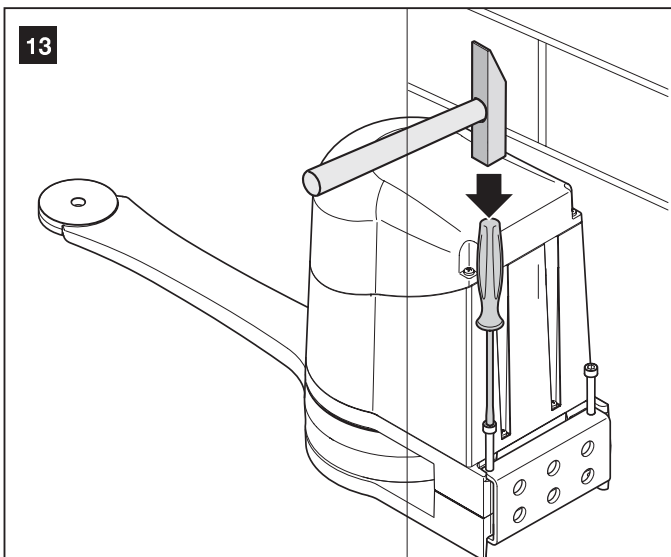
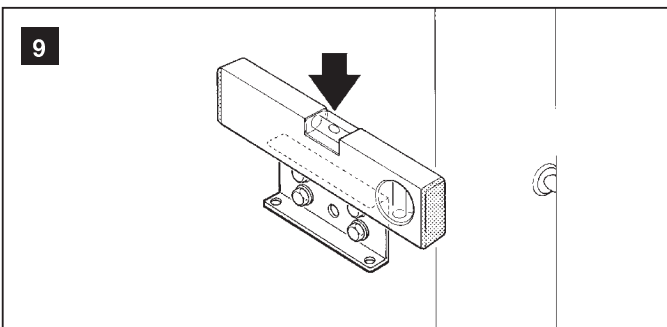
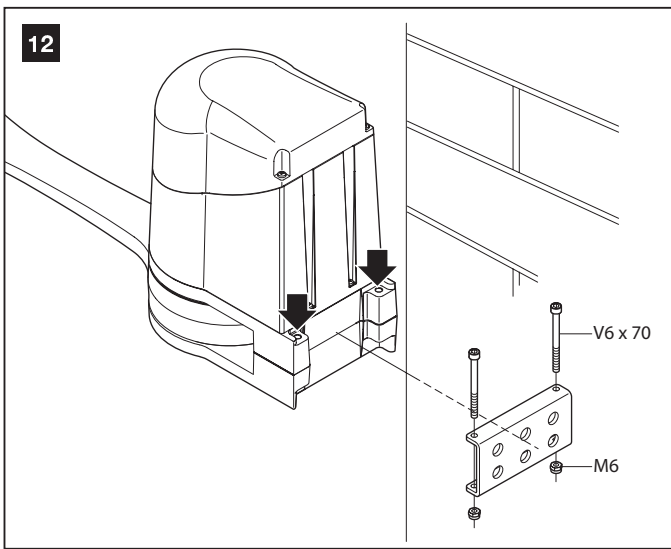
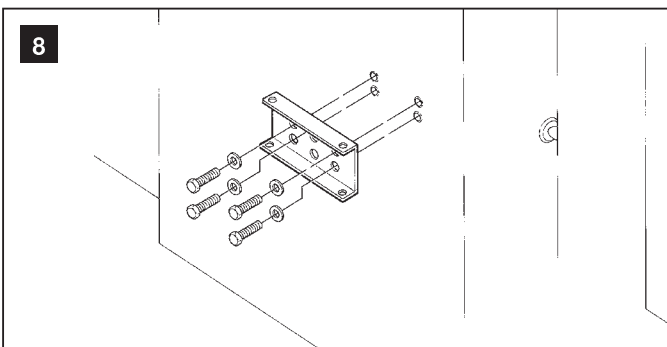
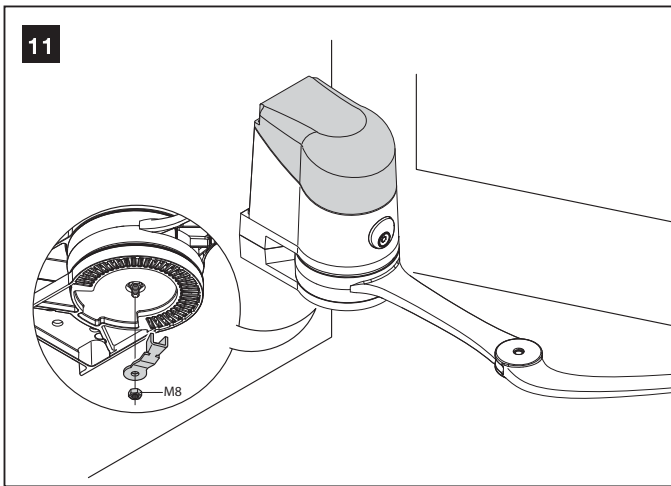
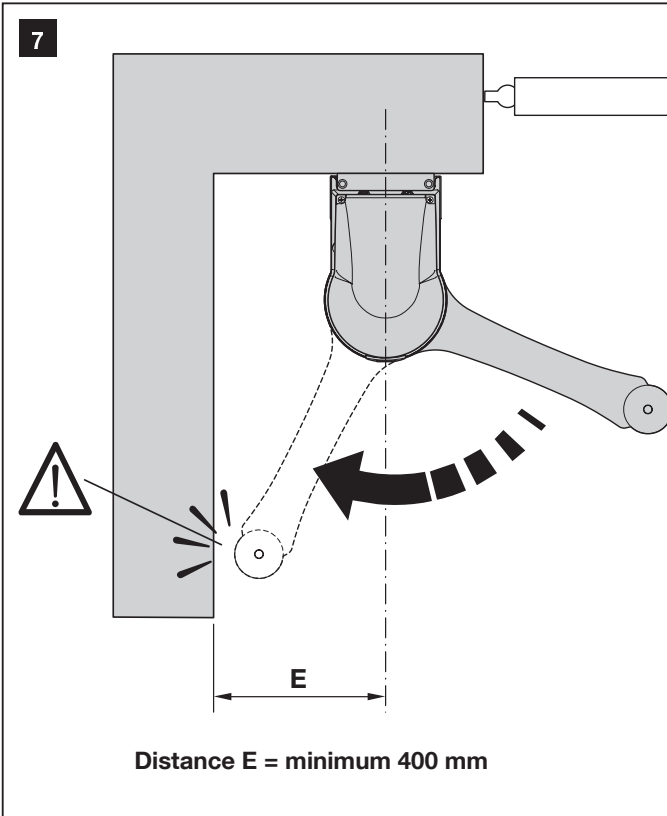
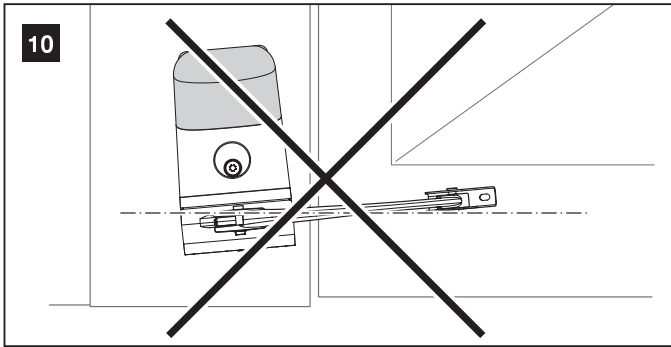
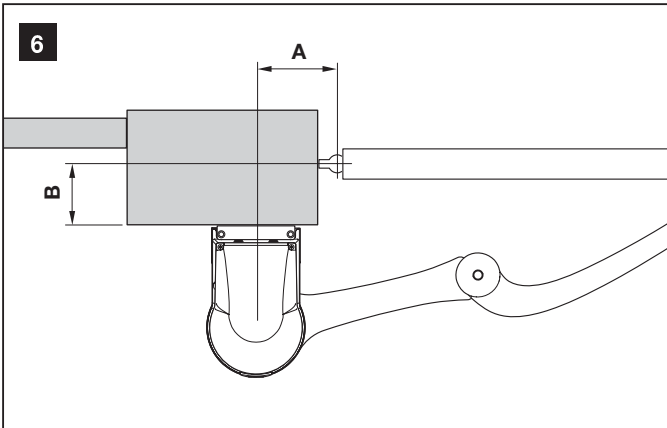

14

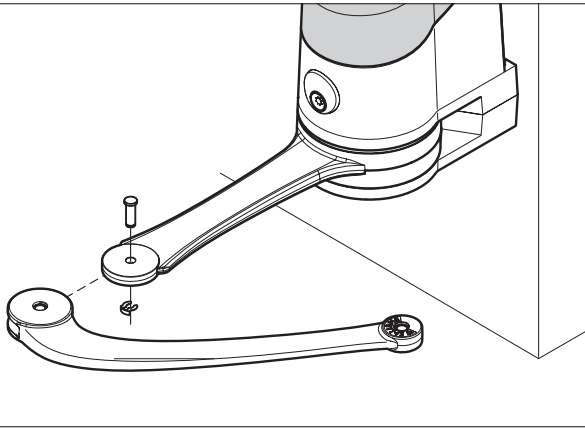

18

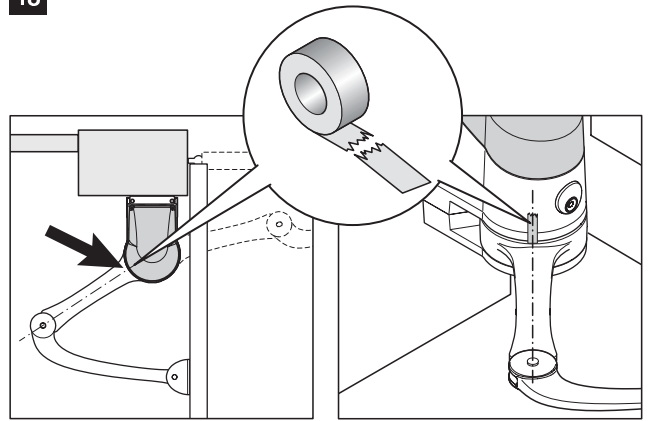

15

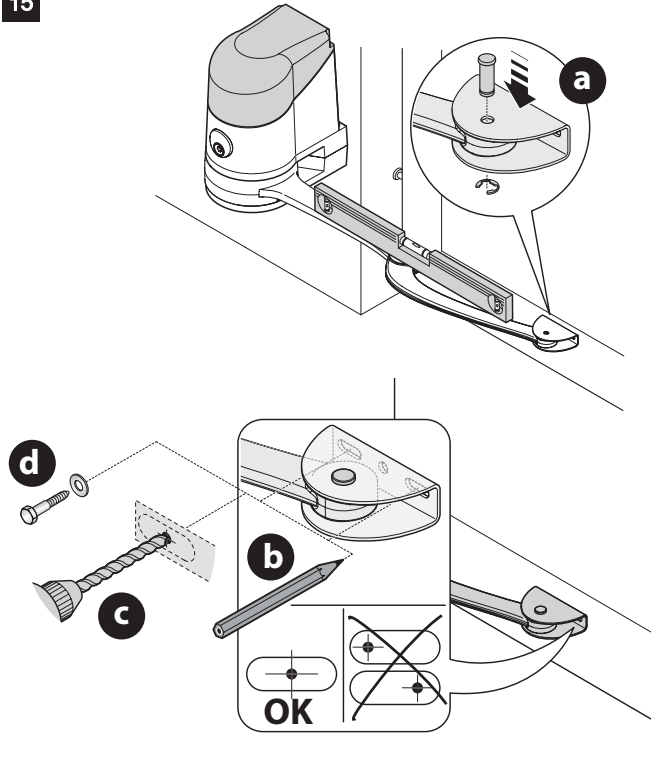

19

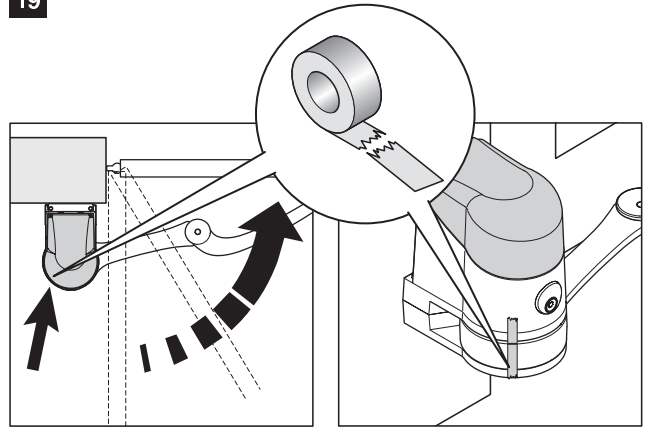

16

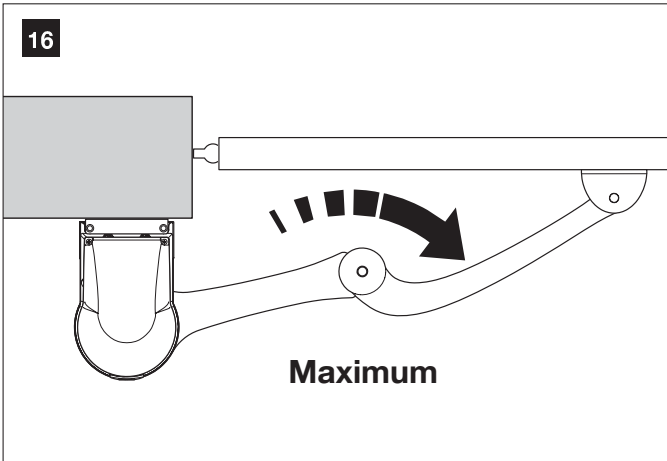

20

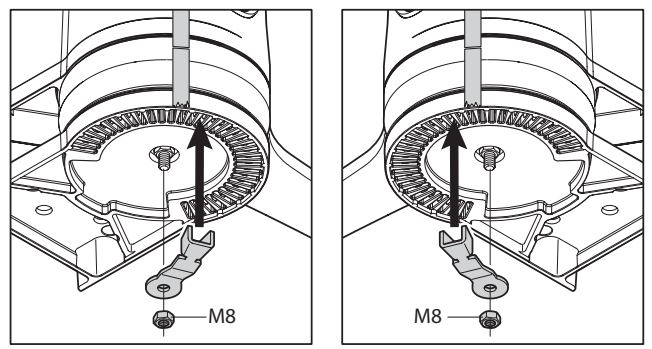

17

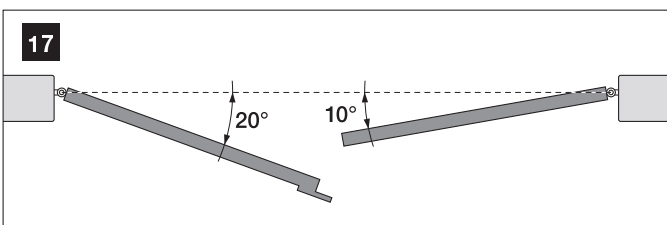

21

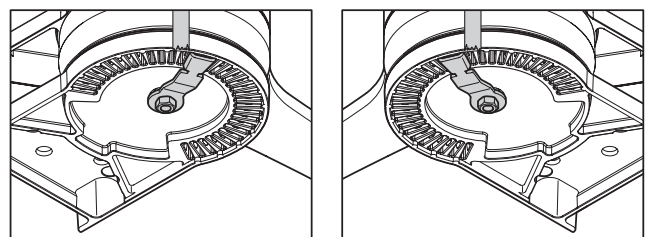

22

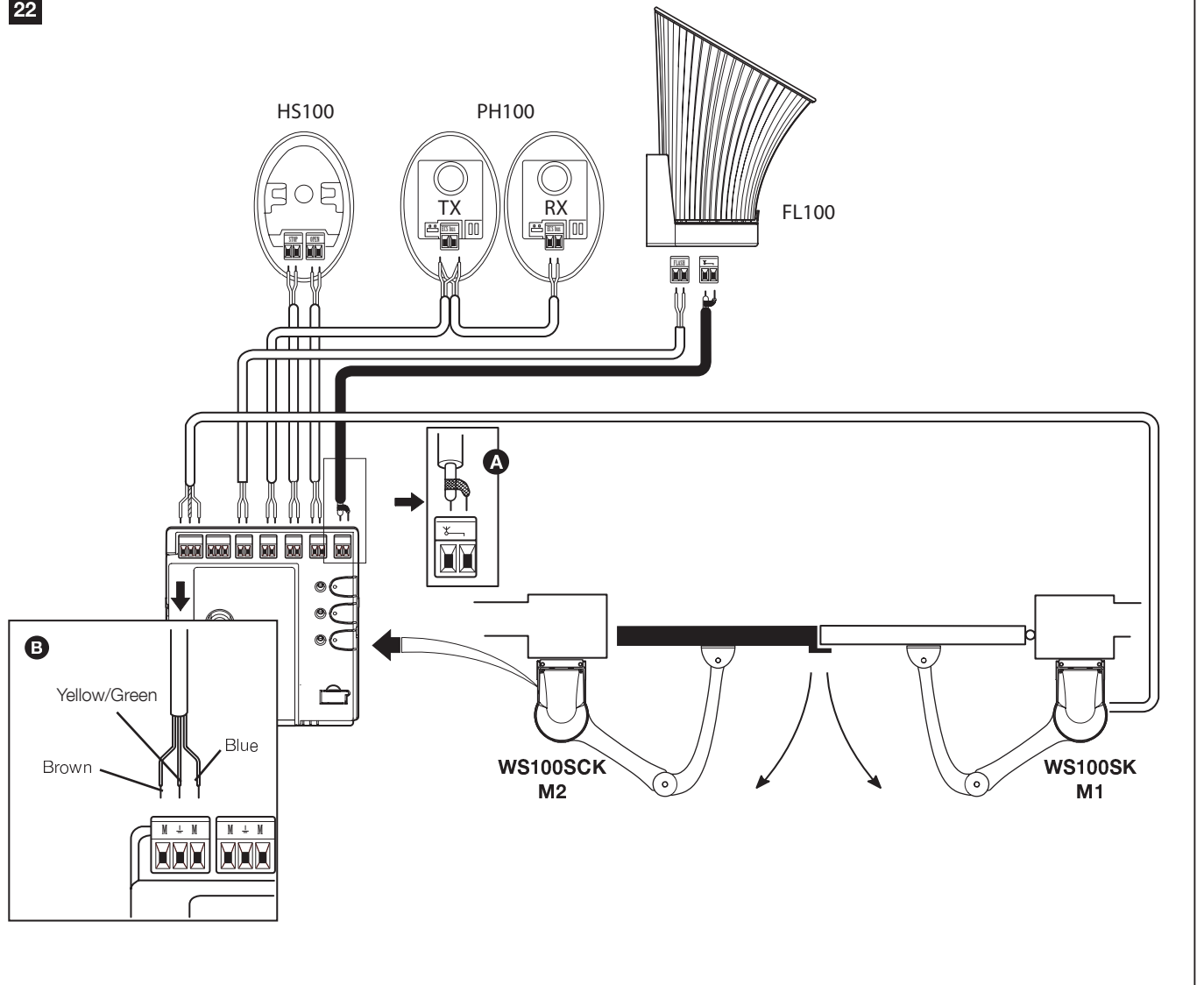

23

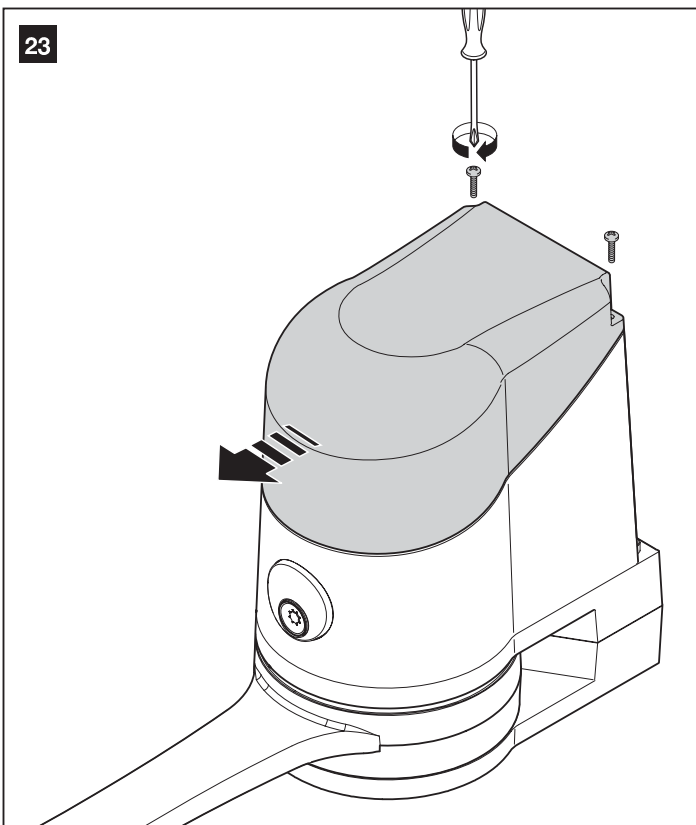

24

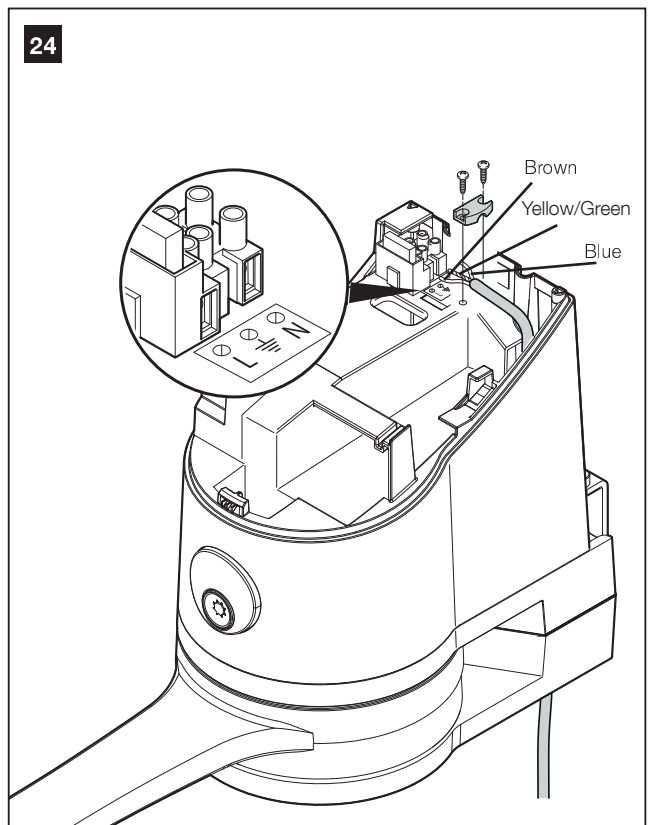

— STEP 6 —

6.1 - INSTALL AND CONNECT PH100 PHOTOCELLS (fig. 25)

Caution: disconnect the power supply to the system before performing any installation operations; if the system is equipped with a PR1 buffer battery, the latter must be disconnected.

Warnings: Be careful not to damage the oring (fig. 25-3) [A].

Choose the positioning of the two elements that make up the photocell (TX and RX) respecting the following requirements:

- Place them at a height of 40-60 cm above ground, at the sides of the area to be protected, and as close as possible to the gate wire (no further than 15 cm).
- Ducting for passage of the cables must be provided at the intended point.
- Point the TX transmitter towards the RX receiver, with a maximum misalignment of 5°.

01. Remove the front glass (fig. 25-1).
02. Position the photocell at the point where the cable passage ducting starts.
03. Mark the drilling points using the bottom as a reference. Drill the holes in the wall using a hammer drill fitted with a 5mm bit and insert the 5 mm screw anchors.
04. To pass the electrical cables through holes (made as desired): see fig. 25-2.
05. Secure the bottom with the relative screws [B] in fig. 25-3 doing so in such a way that the hole on the bottom [C] in fig. 25-3 corresponds to the cables output. 2 self-tapping screws are also provided for fixing on surfaces of different densities.
06. Connect the electric cable to the correct terminals, TX and RX (fig. 25-4). From an electrical point of view, TX and RX are connected in parallel to one another (fig. 25-5) and to the blue terminal on the

control card. You do not need to observe any polarity.

07. Affix the housing cover [D] in fig. 25-6 with the two screws [E] in fig. 25-6 and a Phillips screwdriver. Finally insert the outer cover [F] in fig. 25-6 closing it with slight pressure.

6.2 - INSTALL AND CONNECT FL100 FLASHING INDICATOR (fig. 26)

Choose the location of the flashing indicator, so that it is in the vicinity of the gate and easily visible. This may be secured to a horizontal or vertical surface; fig. 26 shows the two situations:

01. Remove the cover, by unscrewing the screw;
02. Divide the bottom, unscrewing the screws that are used to allow the electrical cables to pass;
03. Mark the drilling points using the bottom as a reference, and doing it so that the hole at the bottom corresponds to the cables output: vertical fixing (A) or horizontal fixing (B);
04. Drill the holes in the wall using a hammer drill fitted with a 6 mm bit and insert the 6 mm screw anchors;
05. Secure the bottom with the screws;
06. Connect the electrical cables in the relevant FLASH and "antenna" terminals as shown in the figure: to facilitate the work you can remove the terminals, make the connections and then reinsert them. In the FLASH terminal is not necessary to comply with any polarity; while in the connection of the shielded antenna cable, connect the sock;
07. Put the lamp door in the base taking care to push it down so that it locks;
08. Join the body of the flashing indicator to the mounting bracket and turn to the left until you hear a click, and secure with the screw.

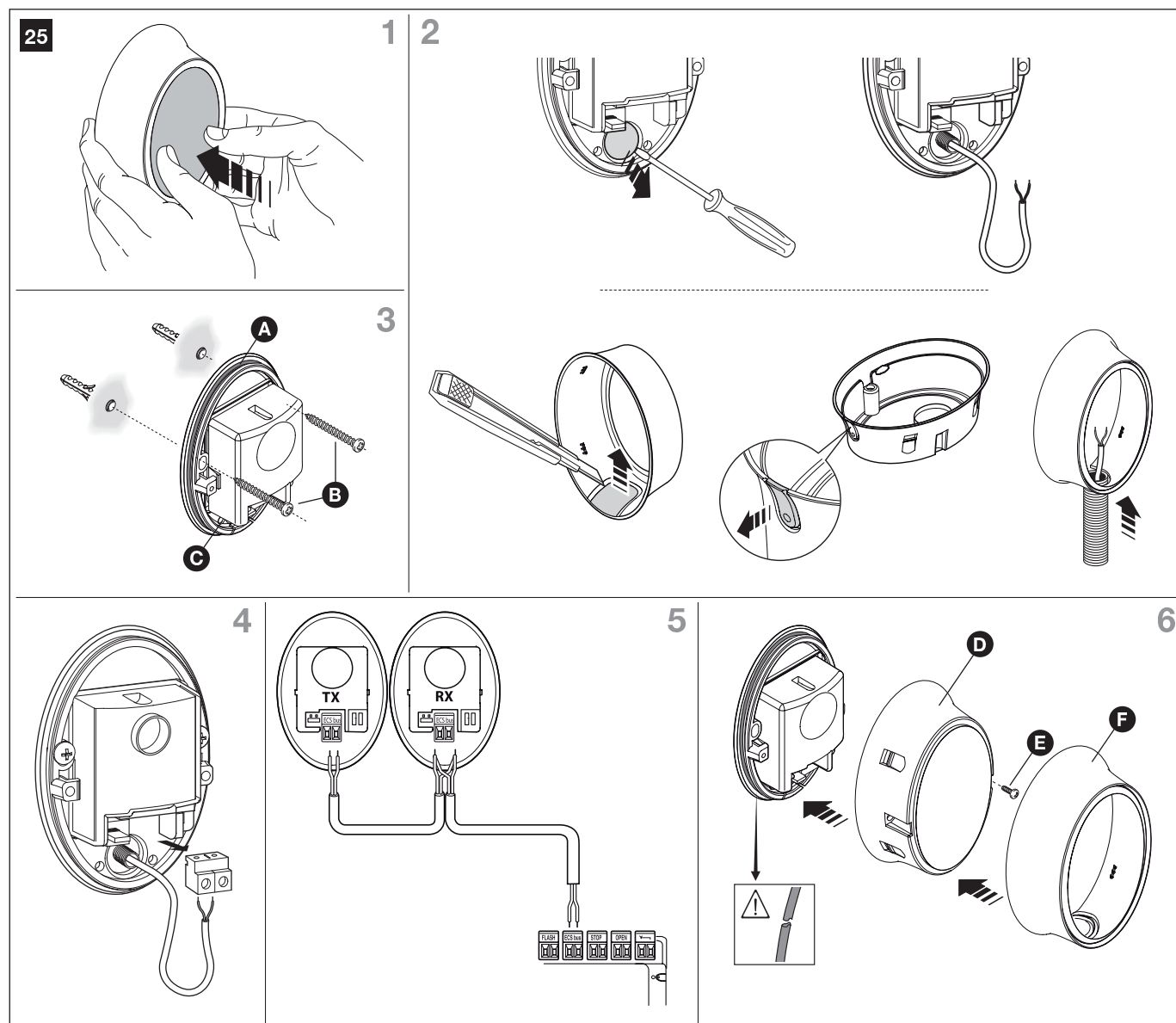

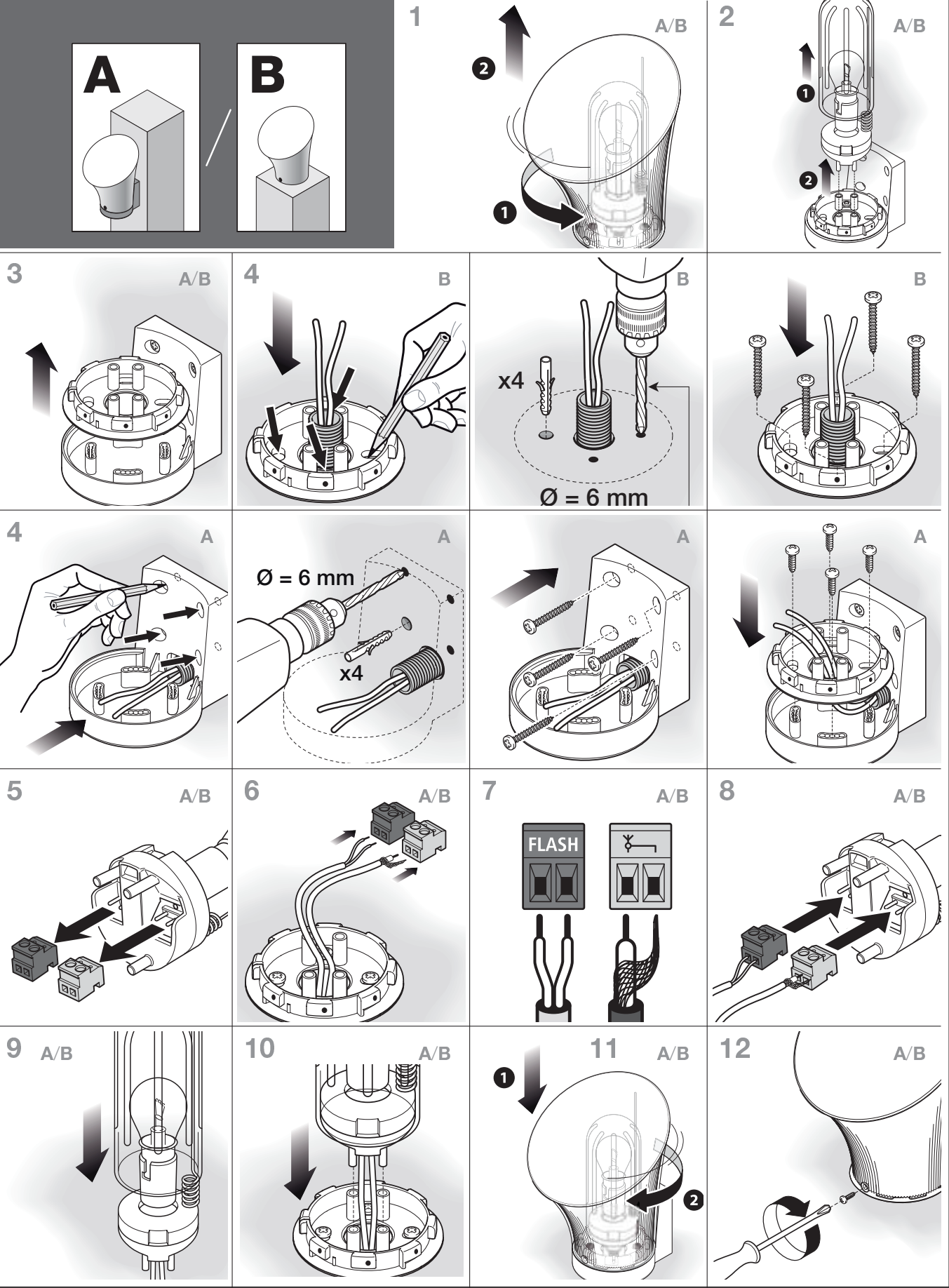



— STEP 7 —

7.1 - POWER SUPPLY CONNECTION**WARNINGS!**

– The PVC power cable is suitable for indoor installations. For installation outdoors, you must protect the entire cable with a protective duct. Alternatively, you can replace the cable with one of type H07RN-F.

– The final connection of the automation to the electrical mains or substitution of the cable supplied must be performed exclusively by a qualified and expert electrician, in compliance with local safety standards and the following instructions.

• For operational and programming tests of the automation, use the cable supplied, inserting the plug into an electrical socket. If the socket is far from the automation, use a suitable extension lead.

• For the test and commissioning phase of the automation you must connect the control unit permanently to the mains power supply, replacing the supplied cable with another of suitable length. To make the connection between the cable and the gearmotor control unit, proceed as described below:

WARNING:

Provide a device inside the electricity supply line that ensures complete disconnection of the automation mechanism from the grid. The disconnection device must have contacts with an opening distance large enough to permit complete disconnection under the conditions sanctioned by overvoltage category III, in accordance with installation regulations. The device ensures quick, safe disconnection from the power supply if needed, and must therefore be positioned in view of the automation mechanism. If, on the other hand, it is located in a position which is not visible, there must be a system for preventing accidental or unauthorized reconnection with the power grid to prevent this risk. The disconnection device is not supplied with the product.

01. Make sure that the gearmotor plug is not plugged into the wall socket.
02. Disconnect the power supply terminal electrical cable from the gearmotor.
03. Loosen the collar found under the terminal and remove the electric cable.
Replace it with a permanent power supply cable.
04. Connect the electric cable to the gearmotor power supply terminal.
05. Tighten the collar to secure the electric cable.

7.2 - PRELIMINARY CHECKS

As soon as the control unit is electrically powered, you are advised to carry out some simple tests:

01. Check that the “ECSBus” LED [A] (fig. 27) is flashing steadily, at a speed of around one flash per second.
02. Check that the “SAFE” LED [B] (fig. 27) on the photocells is flashing (both on TX and RX); the type of flash is not important as this depends on other factors; it is simply important that it is not either permanently lit or unlit.
03. If you have a KS100 key selector switch, check that the night light is on.
04. If the above conditions are not satisfied, it is advisable to switch off the power supply to the control unit and check the electrical connections more carefully. For other useful information see also chapters 10.5 “Troubleshooting” and 10.6 “Diagnostics and signals”.

7.3 - CONNECTED DEVICES RECOGNITION

Once the initial checks are complete, you need to allow the control unit to recognise the devices connected to it on the “ECSBus” and “STOP” terminals.

01. On the control unit, press and hold down P2 [A] (fig. 28) for at least 3 seconds, then release it.
02. Wait a few seconds until the control unit has completed the device recognition procedure.
03. On recognition completion the STOP LED [B] (fig. 28) must remain lit, whilst the P2 LED [C] (fig. 28) must go out. If the P2 LED flashes, it means that an error has occurred; see section 10.5 “Troubleshooting”.

The phase of self-learning the devices connected can be repeated at any time also after installation (such as in the case that a photocell is added); it is sufficient to repeat it from point 01.

7.4 - GATE LEAF OPEN AND CLOSURE ANGLES RECOGNITION

After self-learning the devices, the control unit must recognise the leaf opening and closing angles. In this phase the opening angle of the leaves from the mechanical end closing stop up to the mechanical opening stop is detected. The presence of fixed and sufficiently robust mechanical stops is essential.

01. Carry out motors release using the appropriate keys (see paragraph 11.3 - Usage guide) and move the leaves to mid-course, in such a way that they are free to move in the opening and closing directions; then release the motors.
02. On the control unit press and release P3 [B] (fig. 28); wait for the control unit to perform the recognition: closure of motor M1 up to the mechanical stop, closure of motor M2 up to the mechanical stop, opening of the motor M2 and the motor M1 up to the mechanical opening stop; full closure of M1 and M2.
 - If the first manoeuvre of one or both wings is not a closure, press P3 to stop the recognition phase and then invert the polarity of the opening motor(s) by swapping over the two brown and blue wires on the terminal.
 - If the first motor to carry out a closing move is not M1, press P3 to stop the recognition phase and then swap the motors connections on the terminals.
 - If during the recognition phase a device actuates (photocells, key selector switch, P3 pressed, etc.) the recognition phase will be stopped immediately. It will then be necessary to repeat it in full.
03. If the P3 LED [A] (fig. 28) flashes at the conclusion of the recognition process, it means that an error has occurred; see section 10.5 “Troubleshooting”.

The recognition stage of the opening angles can be repeated again at any time, even after the installation (for example, if one of the opening stops is moved); it is sufficient to repeat the procedure starting from step 1.

7.5 - RADIO TRANSMITTERS CHECK

To check the transmitters, you just need to press on one of its 4 keys, check that the LED flashes and that the automation carries out the command sent.

The command associated to each key depends on the way in which they were stored (see paragraph 10.4 “Memorisation of radio transmitters”). The transmitters supplied are already memorised, and pressing their keys transmits the following commands (fig. 29):

Key T1 = “OPEN” command

Key T2 = “Pedestrian Opening” command

Key T3 = “Open Only” command

Key T4 = “Close Only” command

7.6 - ADJUSTMENTS**7.6.1 - Leaf speed selection**

Leaf opening and closing can be done in two speeds: “slow” or “fast”.

To move between one speed and the other, quickly press P2 (fig. 28); the corresponding P2 LED (fig. 28) lights up or goes out; when the LED is off the speed is “slow”, when the LED is lit the speed is “fast”.

7.6.2 - Selecting the operating cycle type

The closing and opening of the gate can be performed according to two different operating cycles:

- single cycle (semiautomatic): with one command the gate opens, and will remain open until the next command causing it to close.
- Complete cycle (automatic closure): with one command, the gate opens and recloses automatically after a short space of time (for the duration see paragraph 10.1 “Parameter adjustment using radio transmitter”).

To move between one operating cycle and the other, quickly press P3 (fig. 28); the corresponding LED (fig. 28) lights up or goes out; when the LED is off the cycle is “single”, when the LED is lit the cycle is “complete”.

27

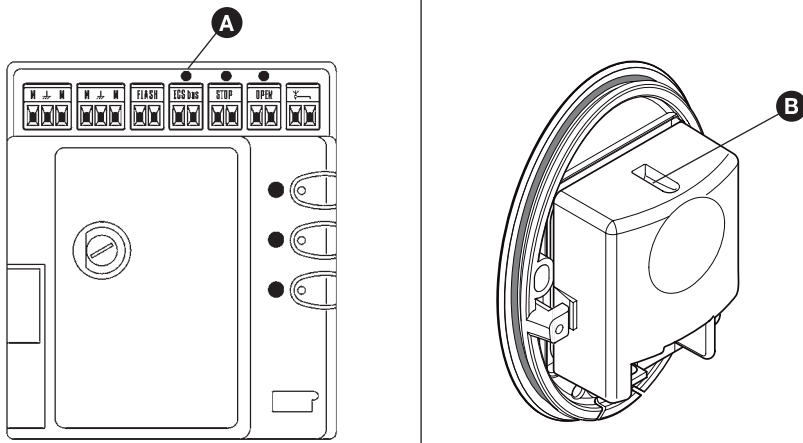

28

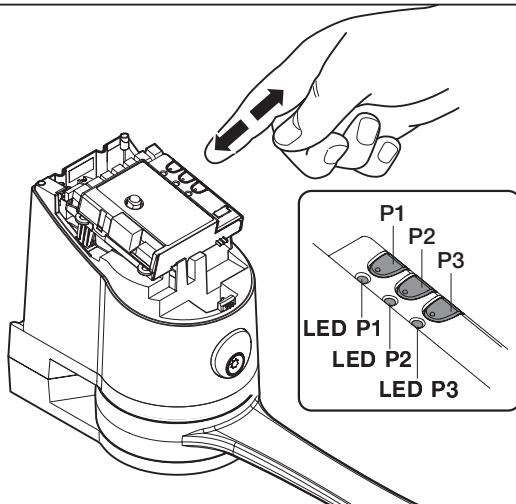

29

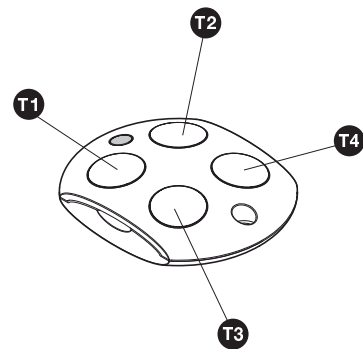

TESTING AND COMMISSIONING

— STEP 8 —

These are the most important stage in the automation system installation procedure in order to ensure the maximum safety levels. Testing can also be adopted as a method of periodically checking that all the various devices in the system are functioning correctly.

Testing and commissioning of the automation must be performed by skilled and qualified personnel, who are responsible for the tests required according to the risks present, and for ensuring observance of all legal provisions, standards and regulations, and in particular all requirements of the standard EN 12445, which establishes the test methods for checking automations for gates.

8.1 - TESTING

01. Ensure that you have strictly complied with the instructions and warnings in STEP 1.
02. Using the selector switch or the radio transmitter, carry out testing of opening and closing the gate and check that the movement of the leaves corresponds to what is expected. It is useful to perform several tests to evaluate the freedom of movement of the gate and any adjustment or installation faults, as well as the presence of particular points of friction.
03. Check the proper operation of all the safety devices, one by one (photocells, safety edges, etc.). In particular, each time a device is activated, the "ECSBus" LED on the control unit flashes longer, confirming that the control unit has recognised this.
04. To check the photocells and make sure that there is no interference with other devices, pass a 5 cm diameter, 30 cm long cylinder (fig. 30) on the optical axis, first near TX, then near RX and finally at the mid-point between them and make sure that in all these cases the device is triggered, switching from the active to the alarm status and

vice-versa; finally, make sure that it causes the intended action in the control unit; for example that it causes the reversal of the movement during the closing manoeuvre.

05. Measure the force as specified in the standard EN 12445. If the motor force control is used as an auxiliary function for reduction of impact force, test and identify the setting that obtains the best results.

30

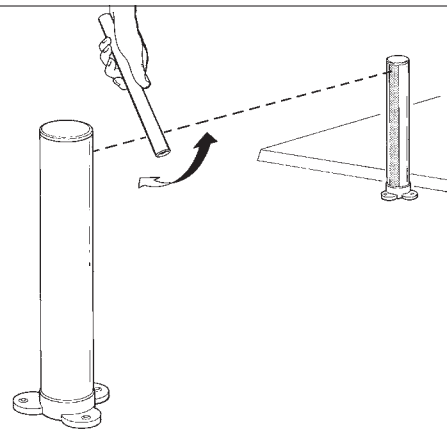

8.2 - COMMISSIONING

Commissioning can take place only after all testing phases have been terminated successfully. Partial or "makeshift" commissioning is strictly prohibited.

01. Draw up the technical dossier of the automation that should include as a minimum: overall design (for example fig. 1), electrical connec-

tions wiring diagram (for example **fig. 5**), risk analysis and related adopted solutions, manufacturer conformance declaration for all the devices used (use Annex 1, "CE conformity declaration for all WS200S components").

02. Post a label on the door providing at least the following data: type of automation, name and address of manufacturer (person responsible for the "commissioning"), serial number, year of manufacture and CE mark.
03. Permanently affix the label present in the package to the gate, concerning the manual operations of releasing and locking the gearmotor.
04. Prepare the declaration of conformity of the automation system and

deliver it to the owner (use Annex 2).

05. Compile the usage guide for the automation system and deliver it to the owner; for this purpose, Annex 3 "Usage guide" (chapter 11.3) can be used as an example.
06. Prepare the maintenance schedule of the automation system and deliver it to the owner; it must provide all directions regarding the maintenance of all the automation devices.
07. Before commissioning the automation, ensure that the owner is adequately informed of all associated residual risks and hazards.



MAINTENANCE

— STEP 9 —

The maintenance operations must be performed in strict compliance with the safety directions provided in this manual and according to the applicable legislation and standards.

The automation devices do not require special maintenance operations; however periodically check, at least once every six months, the perfect

efficiency of all the devices.

For this purpose, to perform all the tests and checks provided for in paragraph 8.1 "Testing" and carried out as provided for in paragraph "User-admissible maintenance operations".

If other devices are present, follow the steps as laid out in the relevant maintenance schedule.



DISPOSAL OF THE PRODUCT

This product is an integral part of the automation system it controls and must be disposed of along with it.

As with installation operations, disposal operations must be performed by qualified personnel at the end of the product's useful life.

This product is made of various types of materials, some of which can be recycled while others must be scrapped. Seek information on the recycling and disposal systems required by local regulations in your area for this product category.

Caution! – some parts of the product may contain pollutants or hazardous substances which, if released into the environment, may cause serious damage to the environment or human health.

As indicated by the symbol on the side, disposal of this product as domestic waste is strictly prohibited. Separate waste into categories for disposal, according to the methods established by local regulations, or return the product to the retailer when purchasing a new version.



Caution! – Local legislation may envisage serious fines in the event of abusive disposal of this product.

FURTHER DETAILS

— STEP 10 —

10.1 - ADVANCED ADJUSTMENTS

10.1.1 - Parameter adjustment using radio transmitter

Using the radio transmitter you can adjust certain operating parameters on the control unit: there are eight parameters.

- 1) Pause time: duration for which the leaves remain open (in the case of automatic closure).
- 2) Pedestrian opening: pedestrian opening mode of the leaves.
- 3) Motor force: maximum force above which the control unit detects an obstacle, and reverses the movement.
- 4) "OPEN" function: sequence of movements associated to each "OPEN" command.
- 5) Open input configuration on control unit: allows you to program the Open input functionality, as described in Table 4.
- 6) Flash output configuration. Allows you to program the Flash output functionality, as shown in Table 4.
 - a) flashing indicator: the output emits one flash per second during the manoeuvre (paragraph 10.6.2).
 - b) courtesy light functionality, the output activates at the start of the manoeuvre and goes out automatically after 60 seconds have expired following completion of the manoeuvre.
 - c) gate open indicator functionality: the output has the following behaviour:
 - off when gate closed,
 - flashes slowly during the opening manoeuvre,
 - flashes quickly during the closing manoeuvre,
 - steady on in all other cases.

Note - Before to modifying the operation of the Flash output, check that the device connected to the output meets the specifications given in the chapter "Product components technical specifications".

- 7) Discharging Motor 1 and Motor 2 when closing: adjusts the length of the "brief reverse" of the motors after execution of the closing manoeuvre, in order to reduce the final residual force.

vre, in order to reduce the final residual force.

- 8) Discharging Motor 1 and Motor 2 when opening: adjusts the length of the "brief reverse" of the motors after execution of the opening manoeuvre, in order to reduce the final residual force. The parameters adjustment operation can be carried out by any one of radio transmitters, as long as it is stored in mode 1, like those supplied (see paragraph 10.4.1 "Mode 1 memorisation").

In the event that no transmitter stored in Mode 1, it is possible to memorise one just for this phase, and delete it straight afterwards (see paragraph 10.4.4 "Deleting a radio transmitter").

CAUTION! – When making adjustments using the transmitter, you must allow the command unit time to recognise the radio command; in practice, the keys must be pressed and released slowly, with at least one second of pressure, one second of release, and so on.

To program the parameters in Table 3:

01. Press T1 and T2 together (**fig. 31**) on the radio transmitter for at least 5 s.
02. Release the two keys.
03. Within three seconds, carry out the action set out in Table 6 based on the parameter to change.

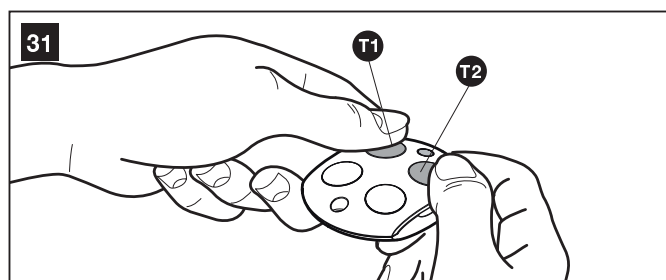

Example: to adjust the pause time to 40 s.

01. Press the T1 and T2 keys and hold them down for at least 5s

02. Release T1 and T2

03. Press T1 three times

All the parameters can be adjusted as required without any contraindication; only the adjustment of the "motor force" could require special care:

- Do not use high force values to compensate for the fact that the gate has anomalous friction points. Excessive force can be detrimental to the functioning of the safety system or can damage the gate.
- If the "Motor force control" is used in support of the system for impact force reduction, the force measurement procedure must be performed after each adjustment, as envisaged by standard EN 12445.
- Weather conditions may affect the movement of the gate. Periodically you may need to readjust.

To program the parameters in Table 4:

01. Press T1 and T3 together (**fig. 32**) on the radio transmitter for at least 5 s.

02. Release the two keys.

03. Within three seconds, carry out the action set out in Table 4 based on the parameter to change.

Example: to adjust the closing discharge of motors 1 and 2 to level 4.

01. Press the T1 and T3 keys and hold them down for at least 5s

02. Release T1 and T3

03. Press T3 four times

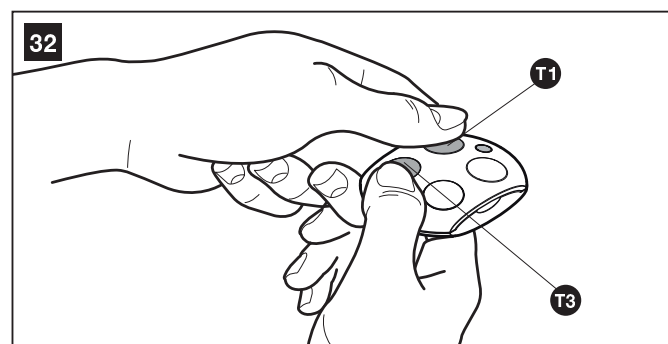

TABLE 3

Parameters	N°	Value	Action: operation to be carried out at step 3 in the recognition phase
Pause time	1	10s	Press T1 once
	2	20s (*)	Press T1 twice
	3	40s	Press T1 three times
	4	80s	Press T1 four times
Pedestrian opening	1	Open 1 leaf halfway	Press T2 once
	2	Fully open 1 leaf (*)	Press T2 twice
	3	2 leaves partially opened to 1/4 of the full course	Press T2 three times
	4	2 leaves partially opened to half of the full course	Press T2 four times
Motor force	1	Low	Press T3 once
	2	Medium low (*)	Press T3 twice
	3	Medium high	Press T3 three times
	4	High	Press T3 four times
"OPEN" function	1	"Open", "Stop", "Close", "Stop"	Press T4 once
	2	"Open", "Stop", "Close", "Open" (*)	Press T4 twice
	3	"Open", "Close", "Open", "Close"	Press T4 three times
	4	Open only	Press T4 four times

(*) Original factory value

TABLE 4

Parameters	N°	Value	Action to perform
Open input configuration on the control unit	1	Open (*)	Press T1 once
	2	pedestrian opening	Press T1 twice
Flash output configuration	1	Flashing light (*)	Press T2 once
	2	Courtesy light	Press T2 twice
	3	Gate open indicator	Press T2 three times
Motor 1 and Motor 2 discharge in closure	1	No discharge (*)	Press T3 once
	2	0.1s (Minimum)	Press T3 twice
	3	0.2s	Press T3 three times
	4	0.3s	Press T3 four times
	5	0.4s (Medium)	Press T3 five times
	6	0.5s	Press T3 six times
	7	0.6s	Press T3 seven times
	8	0.7s (Maximum)	Press T3 eight times
Motor 1 and Motor 2 discharge in opening	1	No discharge (*)	Press T4 once
	2	0.1s (Minimum)	Press T4 twice
	3	0.2s	Press T4 three times
	4	0.3s	Press T4 four times
	5	0.4s (Medium)	Press T4 five times
	6	0.5s	Press T4 six times
	7	0.6s	Press T4 seven times
	8	0.7s (Maximum)	Press T4 eight times

(*) Original factory value

10.1.2 - Checking adjustment using radio transmitter

With a radio transmitter which has been memorised in Mode 1, you can check at any time the adjusted values for each parameter using the following sequence.

To view the parameters in table 5:

01. Press T1 and T2 together on the radio transmitter for at least 5s.
02. Release the two keys.
03. Within three seconds, carry out the action set out in **Table 5** based on the parameter to change.
04. Release the key when the flashing indicator starts flashing.
05. Count the number of flashes and, based on the number, check in Table 3 for the corresponding value.

Example: If, after having pressed T1 and T2 for 5 s and then T1, the flashing indicator will emit three flashes; the pause time has been programmed at 40 s.

To view the parameters in table 6:

01. Press T1 and T3 together on the radio transmitter for at least 5s.
02. Release the two keys.
03. Within three seconds, carry out the action set out in **Table 6** based on the parameter to change.
04. Release the key when the flashing indicator starts flashing.
05. Count the number of flashes and, based on the number, check in Table 4 for the corresponding value.

TABLE 5

Parameter	Action
Pause time	Press and hold T1
Pedestrian leaf	Press and hold T2
Motor force	Press and hold T3
"OPEN" function	Press and hold T4

TABLE 6

Parameter	Action
Open input configuration on the control unit	Press and hold T1
Flash output configuration	Press and hold T2
Discharge on close Motor 1 and Motor 2	Press and hold T3
Discharge on open Motor 1 and Motor 2	Press and hold T4

10.2 - OPTIONAL ACCESSORIES

In addition to the devices present in WS200S, there are others available as optional accessories that can integrate with the automation system.

PR3: 24 V buffer battery; in the event of a lack of mains power supply, this ensures around ten full cycles.

PF: 24 V solar energy system; useful in cases where power from the fixed electrical grid is unavailable.

PT50: Pair of 500 mm high columns with a photocell

PT100: Pair of 1000 mm high columns with two photocells

For information on new accessories, refer to the Mhouse product catalogue or visit www.niceforyou.com.

DS1: digital selector switch which allows you, after having correctly entered the secret combination, to control the automation remotely. For programming see paragraph 10.4.6

10.2.1 - Installing the PR3 buffer battery (fig. 33)

CAUTION! - Electrical connection of the battery to the unit must be performed exclusively after completing all stages in installation and programming, as the battery is an emergency power supply.

To install and connect the PR3 buffer battery to the command unit, see **fig. 33** and refer to the PR3 instruction manual.

When automation is powered by the buffer battery, after 60 s following completion of a manoeuvre, the control unit automatically turns off the "ECSbus" output (and all the devices connected to it), the Flash output and all of the leds, excluding the ECSbus led that will flash more slowly; this is the "Standby" function. When a command arrives, the control unit will reset to normal functioning (after a brief delay). This feature is designed to reduce power consumption, as this is a very important consideration with battery power.

10.2.2 - Install the PF solar power supply system (fig. 34)

CAUTION! - When the automation mechanism is powered exclusively by the "PF" solar power supply system, IT MUST NOT BE POWERED by the electricity grid at the same time.

To connect the PF solar power supply system to the control unit, see **fig. 34** and refer to the PF instruction manual.

When automation is powered by the solar panel, after 60 s following completion of a manoeuvre, the control unit automatically turns off the "ECSbus" output (and all the devices connected to it), the Flash output and all of the leds, excluding the ECSbus led that will flash more slowly; this is the "Standby" function. When a command arrives, the control unit will reset to normal functioning (after a brief delay). This feature is designed to reduce power consumption, as this is a very important consideration with solar power.

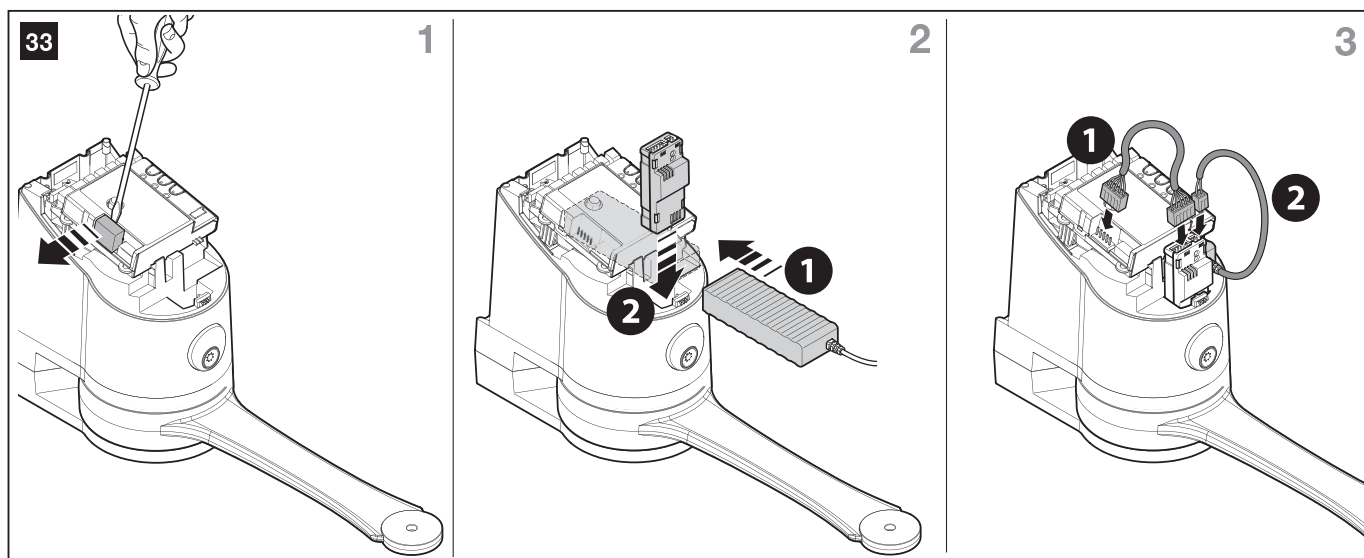

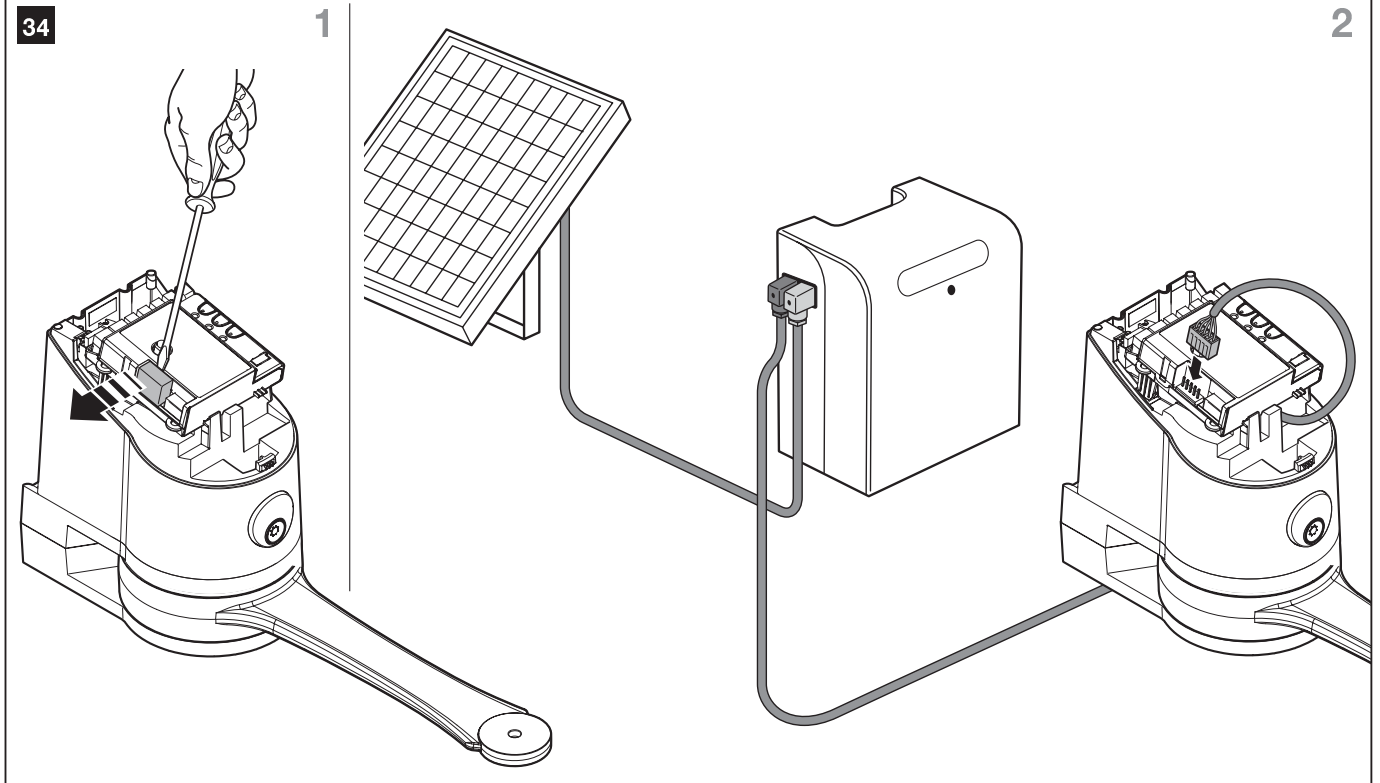

10.2.3 - Calculation of maximum number of cycles per day

This product is expressly designed to also be able to operate with the power supply system of the PF solar energy model. Suitable technologies have been supplied to minimise the power consumption when the automation is stopped, by turning off all the devices that are not essential to the operation (for example the photocells or the key selector light). In this way all the available energy is stored in the battery, and will be used for the movement of the gate.

Caution! - When the automation mechanism is powered by PF, it cannot and IT MUST NOT BE POWERED by the electricity grid at the same time.

Usage limits: maximum number of cycles per day, in a given period of the year.

The PF solar-powered system allows full energy independence for the automation, whilst the energy produced by the solar energy panel and stored in the battery remains higher than that consumed by the gate manoeuvres. With a simple calculation it is possible to estimate the maximum number of cycles per day that the automation can execute in a given period of the year in order that this energy balance remains positive.

The first part of the **available energy calculation**, is explained in the PF instruction manual; the second part of **calculation of energy consumed** and therefore, the maximum number of cycles per day, is explained in this chapter.

Establish the available energy

To determine the available energy (see also the PF instruction manual) proceed as follows:

01. In the ground map supplied in the PF kit instruction manual, locate the system installation point; then obtain the value of **Ea** and the degrees of **latitude** of the location (Ex. $Ea = 14$ and degrees = $45^\circ N$)
02. In the graphs (North or South) shown in the PF kit instruction manual, locate the curve which relates to the degrees of **latitude** of the position (ex. $45^\circ N$)
03. Choose the **period of the year** for which you wish to do the calculation, or choose the **lowest point** of the curve if you wish to carry out the calculation for **the harshest period** of the year; then find the corresponding **Am** value (i.e., December, January: $Am = 200$)
04. Calculate the available energy value **Ed** (produced by the panel) by multiplying: $Ea \times Am = Ed$ (i.e. $Ea = 14$; $Am = 200$ thus $Ed = 2800$)

Establish the energy consumed

To calculate the energy consumed by the automation proceed as follows:

05. In the table below choose the box corresponding to the intersection of the row with the **weight** and the column with the **opening angle** of the gate. The box contains the **severity index** (K) of each manoeuvre (i.e. WU200S with 130kg leaf and opening of 100° ; $K = 106$).

	Opening angle		
Leaf weight	$\leq 95^\circ$ ($B \approx 250$)*	$95-105^\circ$ ($B \approx 180$)*	$105-110^\circ$ ($B \approx 70$)*
< 75 kg	69	88	93
75-100 kg	85	108	115
100-125 kg	102	130	139
125-150 kg	118	151	161

(*) the value of B shown in the table represents the optimum value; in the event that B is less than this value, add 20% to the K value shown in the table.

06. In **table A** below, select the box corresponding to the intersection of the row with the value of Ed and the column with the value of K. The box contains the maximum possible number of cycles per day (e.g. $Ed = 2800$ and $K = 106$; daily cycles ≈ 22)

If the number obtained is too low for the intended use, or falls within the "not recommended usage area", you can evaluate the use of 2 or more solar power panels or a solar power panel of greater power. Contact the Nice Support Service for further information.

The method described, allows you to calculate the maximum possible number of cycles **per day** that the automation is capable of carrying out, according to the solar energy supplied. The calculated value should be considered as the average value and equal for all the days of the week. Considering the presence of the accumulator, which acts as an energy "store", and considering that the accumulator allows you independent automation even during long periods of bad weather (when the solar panel produces very little energy) it is therefore possible to occasionally exceed the maximum number of cycles per day, provided that the average on 10-15dd is within the limits.

In **table B** below the maximum possible number of cycles is shown, according to the **severity index** (K) of the manoeuvre, using the **stored solar energy** of the accumulator. It is assumed that initially the accumulator is fully charged (e.g., after a long period of good weather or after a refill with the optional power supply model PCB) and that the operations are carried out within a period of 30 days

When the accumulator has exhausted its energy, the led will start to report on the discharged status of the battery with a short flash every 5 seconds, accompanied by a "beep" sound.

TABLE A - Maximum number of cycles per day

To	K=70	K=80	K=90	K=100	K=110	K=120	K=130	K=140	K=150	K=160
9500	131	115	102	92	84	77	71	66	61	58
9000	124	109	97	87	79	73	67	62	58	54
8500	117	103	91	82	75	68	63	59	55	51
8000	110	96	86	77	70	64	59	55	51	48
7500	103	90	80	72	65	60	55	51	48	45
7000	96	84	74	67	61	56	52	48	45	42
6500	89	78	69	62	56	52	48	44	41	39
6000	81	71	63	57	52	48	44	41	38	36
5500	74	65	58	52	47	43	40	37	35	33
5000	67	59	52	47	43	39	36	34	31	29
4500	60	53	47	42	38	35	32	30	28	26
4000	53	46	41	37	34	31	28	26	25	23
3500	46	40	36	32	29	27	25	23	21	20
3000	39	34	30	27	25	23	21	19	18	17
2500	31	28	24	22	20	18	17	16	15	14
2000	24	21	19	17	15	14	13	12	11	11
1500	17	15	13	12	11	10	9	9	8	8
1000	10	9	8	7	6	6	5	5	Usage not recommended area	

TABLE B - Maximum number of cycles just on accumulator charge

K=70	K=80	K=90	K=100	K=110	K=120	K=130	K=140	K=150	K=160
794	695	618	556	505	463	428	397	371	348

10.3 - DEVICES ADDITION OR REMOVAL

Devices can be added to or removed from an automation which is automated with WS200S at any time.

Caution! – Do not add devices before you have checked that they are fully compatible with WS200S; for details please refer to the NICE Support Service.

10.3.1 - ECSBus

ECSBus is a system which allows you to connect ECSBus devices using only two wires which carry both the power supply and the communication signals. All the devices are connected in parallel on the 2 wires of the ECSBus itself; each device is individually recognised because a univocal address is assigned to it during the installation.

The control unit, via the appropriate recognition phase, identifies one by one all connected devices and is able to detect with extreme safety all possible faults. For this reason, each time a device connected to ECSBus is added or removed the control unit must go through the recognition process; see paragraph 10.3.3 “Recognition of other devices” devices.

10.3.2 - STOP input

STOP is the input that stops movement immediately, (with a brief reverse of the manoeuvre). Devices with output featuring normally open “NO” contacts and devices (for instance, the KS100 selector switch), and with normally closed “NC” contacts, as well as devices with 8.2kΩ constant resistance output, like sensitive edges, can be connected to this input.

Multiple devices, even of different types, can be connected to the STOP input if suitable arrangements are made; see **Table 7**.

		1st device type:		
2nd device type:		NO	NC	8.2 KΩ
	NO	In parallel (<i>note 2</i>)	(<i>note 1</i>)	In parallel
	NC	(<i>note 1</i>)	In series (<i>note 3</i>)	In series
	8.2KΩ	In parallel	In series	(<i>note 4</i>)

Note 1. NO and NC combinations are possible by placing the 2 contacts in parallel, taking care to place a 8.2kΩ resistance in parallel to the NC contact (thus enabling the combination of 3 devices: NO, NC and 8.2kΩ).

Note 2. Any number of NO devices can be connected to each other in parallel.

Note 3. Any number of NC devices can be connected to each other in series.

Note 4. Only two devices with 8.2kΩ constant resistance output can be connected in parallel; if needed, multiple devices must be connected “in cascade” with a single 8.2 kΩ terminal resistance.

Caution! – If the STOP input is used to connect devices with safety

functions, only the devices with 8.2 kΩ constant resistance output guarantee the failsafe category 3.

As in the case of ECSBus, the control unit recognises the type of device connected to the STOP input during the self-learning phase; after which a STOP command is activated whenever a variation with respect to the learned status is detected.

10.3.3 - Recognition of Other Devices

Normally the recognition of the devices connected to the ECSBus and the STOP input takes place during the installation stage. However, if new devices are added or old ones removed, the recognition process can be gone through again by proceeding in the following way:

01. On the control unit, press and hold the P2 button (**fig. 34**), for at least three seconds, then release the button.
02. Wait a few seconds until the control unit has completed the device recognition procedure.
03. When the recognition procedure has completed, the P2 LED (**fig. 35**) will go off. If the P2 LED flashes, it means that an error has occurred; see section 10.5 “Troubleshooting”.
04. After you have added or removed any devices, the automation system must be tested again according to the directions contained in paragraph 8.1 “Testing”.

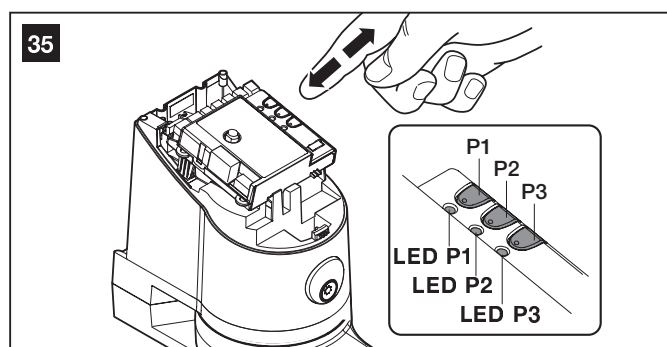

10.3.4 - Optional photocells addition

At any time, you can install additional photocells in addition to those already provided as standard with WS200S. In an automation with sliding gates, it is possible to place them as shown in **fig. 37**.

For correct photocells recognition by the control unit, you need to carry out its addressing, through the use of suitable electrical jumpers. The addressing operation must be carried out both on TX and RX (setting the electrical jumpers in the same way) and by making sure there are no other couples of photocells with the same address. The photocells addressing serves both for correct recognition by other devices on the ECSBus, and to assign the function performed.

01. Open the photocell housing.
02. Locate the position in which they are installed according to Figure 37 and install the jumper according to **Table 8**.
The unused jumpers are stored in a compartment on their reserve, to be able to be reused in the future (fig. 36).
03. Carry out the recognition phase as described in paragraph 10.3.3 "Recognition of other devices".

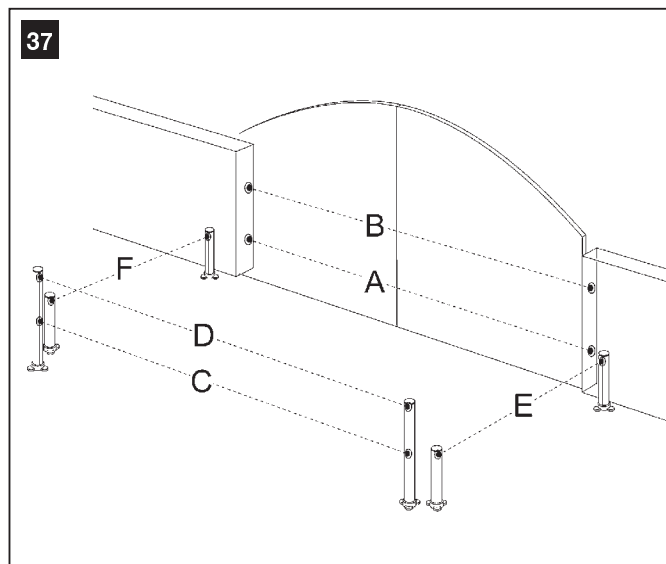
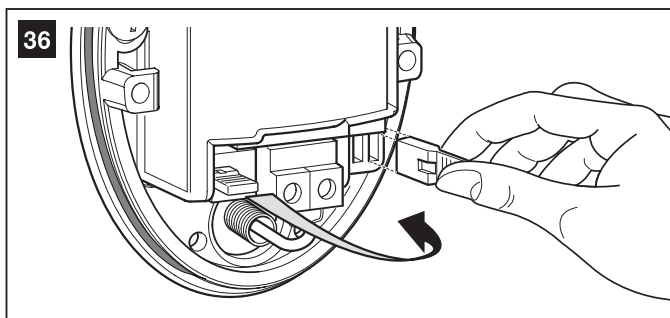

Photocell	Jumper	Photocell	Jumper
A Photocell h = 50cm activated when gate closes		D Photocell h = 100cm activated when gate opens and closes	
B Photocell h = 100cm activated when gate closes		E Right photocell activated when gate opens	
C Photocell h = 50cm activated when gate opens and closes		F Left photocell activated when gate opens	

10.4 - RADIO TRANSMITTERS MEMORISATION

The control unit contains a radio receiver for transmitters GTX4; the transmitter contained in the package is already memorised and working. If you want to memorise a new radio transmitter you have two possible choices:

• **Mode 1:** in this "mode" the radio transmitter is used in full, that is, all the keys carry out a predefined command (the transmitter supplied with WS200S is memorised in Mode 1). It is clear that in mode 1 a radio transmitter can be used to control a single automation; namely:

Key T1	"OPEN" command
Key T2	"Pedestrian Opening" command
Key T3	"Open Only" command
Key T4	"Close Only" command

• **Mode 2:** one of the four available commands can be assigned to each key. By using this mode correctly, you can also control 2 or more different automations; for example:

Key T1	"Open Only" command Automation No. 1
Key T2	"Close Only" command Automation No. 1
Key T3	"OPEN" command Automation No. 2
Key T4	"OPEN" command Automation No. 3

Naturally each transmitter is a specific case and in the same control unit there may be some stored in mode 1 and others in mode 2.

Overall, the memory capacity is 150 units; mode 1 memorisation occupies a unit for each transmitter while mode 2 occupies a unit for each key.

Caution! – Since the memorization procedures are timed (10s), you must read the instructions in the following paragraphs before you proceed with their execution.

10.4.1 - Mode 1 memorisation

01. Press P1 (**fig. 35**) for at least 3 s. When the LED P1 lights up, release the key.
02. Within 10s, press any key on the radio transmitter to be memorised and hold it down for at least 3s. If the procedure was memorised correctly, the P1 LED will flash 3 times.
03. If there are other transmitters to memorise, repeat step 2 within another 10 seconds; otherwise, the memorisation phase will stop automatically.

10.4.2 - Mode 2 memorisation

With memorisation of the radio transmitter in Mode 2, each key can be associated with any of the commands listed in table 10.

In Mode 2 each key requires its own memorisation phase.

01. If the transmitter to be memorised is already memorised (this is the case with the supplied transmitters that are already stored in mode 1) you must first delete the transmitter by performing the procedure described in: "10.4.4 - Deleting a radio transmitter".
02. Press P1 [**B**] (**fig. 40**) on the control unit, the same number of times as your desired command, as shown in **Table 9** (e.g. 3 times for the "Open Only" command).
03. Check that LED P1 emits a number of quick flashes which are equal to the selected command.
04. Within 10 seconds press the desired button on the transmitter to be memorised, holding it down for at least 2 seconds. If the procedure was memorised correctly, the P1 LED will flash slowly 3 times.
05. If there are other transmitters to memorise for the same command type, repeat step 03 within another 10 seconds; otherwise, the memorisation phase will stop automatically.

TABLE 9

1 time	“Open” command	Commands the automation as described in table 3 (Open function)
2 times	“Pedestrian opening” command	Causes partial opening of one or two leaves as described in table 3 (Pedestrian Opening)
3 times	“Open only” command	Causes the leaves to open (open - stop - open etc.)
4 times	“Close only” command	Causes the leaves to close (close - stop - close etc.)
5 times	“Stop” command	Halts the manoeuvre
6 times	“Apartment block open” command	The command has no effect on opening, when closing the command causes the movement to reverse, that is, opens the leaves
7 times	“High priority open” command	Works also when the automation is locked
8 times	“Pedestrian opening 2” command	Causes partial opening of leaf M2, equal to halfway
9 times	“Pedestrian opening 3” command	Causes partial opening of both the leaves, equal to halfway
10 times	“Open + lock automation” command	Causes an opening manoeuvre and when this is complete, the automation is locked; the control unit will not accept any command other than “High priority open” and “Release” of the automation
11 times	“Close + lock automation” command	Causes a closure manoeuvre and when this is complete, the automation is locked; the control unit will not accept any command other than “High priority open” and “Release” of the automation
12 times	“Lock automation” command	Causes a halt of the manoeuvre and locks the automation; the control unit will not accept any command other than “High priority open” and “Release” of the automation.
13 times	“Release automation” command	Causes automation release and reset to normal operation

10.4.3 - “Remote” memorisation

You can store a new radio transmitter in the control unit, without pressing its keys directly. A previously memorised and operational “OLD” transmitter must be available. The “NEW” radio transmitter to be stored will “inherit” the characteristics of the OLD one; that is, if the OLD radio transmitter is memorised in mode 1, the NEW will be memorised in mode 1; in this case, during the programming phase, any key can be pressed on either of the two transmitters. If, on the other hand, the OLD radio transmitter is memorised in Mode 2, you must press the key with the command you want on the OLD transmitter, and on the NEW, the key to which you want to associate that command.

Holding the two transmitters, position yourself within the operating range of the automation and perform the following operations:

01. Press the key on the NEW radio transmitter and hold it down for at least 5s, then release it.
02. Press the button on the OLD radio transmitter 3 times slowly.
03. Press the key on the NEW radio transmitter once slowly.

At this point, the NEW radio transmitter will be recognised by the control unit, and take on the characteristics that the OLD one had.

If there are other transmitters to memorise, repeat all the above steps for each new transmitter.

10.4.4 - Deleting a radio transmitter

If you have available only one radio transmitter, use this operation to delete it.

If the transmitter is memorised in Mode 1, one deletion phase is sufficient and at point 3 you may press any key. If the transmitter is stored in mode 2, a deletion phase is required for each memorised key.

01. Press the P1 key [B] key (**fig. 38**) on the control unit and hold it down.
02. Wait until the LED P1 lights up, within three seconds.
03. Press the key of the radio transmitter to be deleted for at least three seconds. If cancellation was successful the LED P1 will flash quickly five times. If LED P1 emits 1 slow flash, the deletion phase was unsuccessful because the transmitter is not memorised.
04. If there are other transmitters to delete, keeping P1 depressed, repeat step 3 within another 10 seconds; otherwise, the deletion phase will stop automatically.

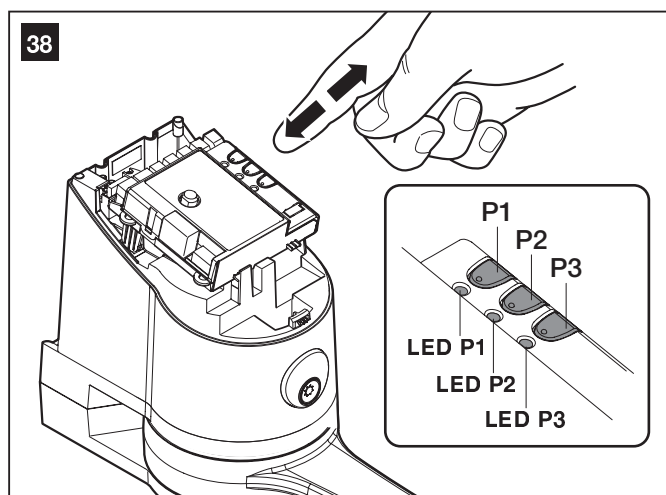

10.4.5 - Deleting all memorised radio transmitters

This operation deletes all memorised transmitters.

01. Press the P1 key [B] key (**fig. 38**) on the control unit and hold it down.
02. Wait for the P1 LED to light up, then wait for it to switch off and then wait for it to flash 3 times.
- 03 Release button P1 exactly during the third flash.
- 04 Wait for around 4s for the deletion phase to finish; during this time the LED P1 will flash very quickly.

If the procedure is successful, after a few moments the P1 LED will flash slowly 5 times.

10.5 - TROUBLESHOOTING

Table 10 contains instructions to help you solve malfunctions or errors that may occur during the installation stage or in case of failure.

10.6 - DIAGNOSTICS AND SIGNALS

A few devices give out special signals that allow you to recognise the operating status or possible malfunctions.

10.6.1 - Photocells

In the photocells, there is a "SAFE" LED [A] (fig. 40) which allows you to check the operating state at any time, see **Table 11**.

TABLE 10 (fig. 38)

Symptoms	Probable cause and possible solution
The radio transmitter is not emitting a signal (the LED [A] is not lit)	<ul style="list-style-type: none"> • Check to see if the batteries are spend. Replace if necessary (see paragraph 11.5)
The manoeuvre does not start and the LED "ECSBbus" [B] does not flash	<ul style="list-style-type: none"> • Make sure that the power supply cable is properly inserted into the electrical network socket • Check to see if the fuses [E] or [F] are blown; if necessary, identify the reason for the failure and then replace the fuses with others of equal value
No manoeuvre starts and the flashing light is off	<ul style="list-style-type: none"> • Make sure that the commands are actually received. If the command is delivered to the OPEN input the relative "OPEN" LED [D] must light up; otherwise if the radio transmitter is used, the "ECSBus" LED flashes slowly twice
No manoeuvre starts and the flashing light flashes a few times	<ul style="list-style-type: none"> • Check that the STOP input is active, that is, the LED "STOP" [C] is lit. If this does not happen, check the device connected to the STOP input • The photocells test which is carried out at the start of each manoeuvre has not given a positive result; check them, referring also to compliance with Table 11
The manoeuvre starts but it is immediately followed by a reverse run	<ul style="list-style-type: none"> • The selected force could be too low for this type of gate. Check to see whether there are any obstacles; if necessary increase the force as described on page 15
The manoeuvre is carried out but the flasher does not work	<ul style="list-style-type: none"> • Make sure that there is voltage on the flashing light's FLASH terminal during the manoeuvre (being intermittent, the voltage value is not important: approximately 10-30 Vac); if there is voltage, the problem is due to the lamp; in this case replace the lamp with one having the same characteristics

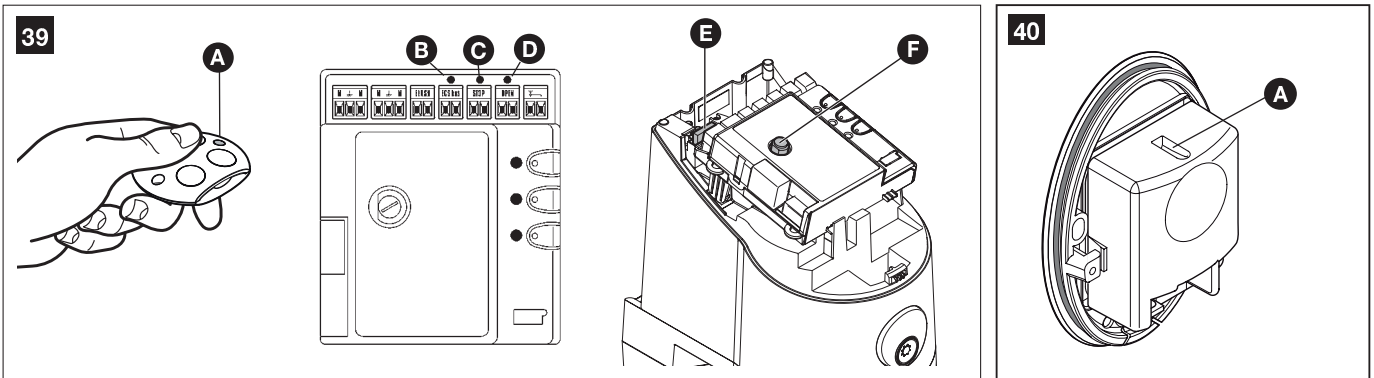

TABLE 11

"SAFE" LED	STATUS	ACTION
Off	The photocell has no power supply or is faulty	Check that on the terminals of the photocell there is a voltage of approximately 8-12 Vdc; if the voltage is correct, it is likely that the photocell is faulty.
3 quick flashes and 1 second pause	Device not recognised by control unit	Repeat the recognition procedure on the control unit. Check that all photocell pairs on the ECSBus have different addresses (see Table 8)
1 very slow flash	The RX is receiving optimum signal	Normal operation
1 slow flash	The RX is receiving good signal	Normal operation
1 quick flash	The RX is receiving poor signal	Normal operation but it is necessary to check the TX-RX alignment and correct cleaning of the glasses
1 very quick flash	The RX is receiving bad signal	It is at the limit of normal operation. It is necessary to check the TX-RX alignment and correct cleaning of the glasses
Always on	The RX is receiving no signal	Check for any obstruction between TX and RX. Check that the LED on TX emits a slow flashing. Check the TX-RX alignment

10.6.2 - Flashing indicator

During the manoeuvre the flashing indicator flashes once every second. When something is wrong the flashes are more frequent (every half sec-

ond); the light flashes twice with a second's pause between flashes, see **Table 12**.

TABLE 12

Quick flashes	Status	Action
1 flash 1 second pause 1 flash	Error on ECSbus	At the beginning of the manoeuvre, the verification of the devices present does not correspond to those learned; check and possibly try to redo the learning (10.3.3 "Recognition of other devices"). Some faulty devices may be present; check and replace them.
2 flashes 1 second pause 2 flashes	Triggering of a photocell	At the start of the manoeuvre, one or more photocells are preventing movement; check to see if there are any obstacles. During the movement, although the obstacle is effectively present, no action is required.
3 flashes 1 second pause 3 flashes	Action of the "motor force" limiting device	During the movement, the gate experienced excessive friction; identify the cause.
4 flashes 1 second pause 4 flashes	Activation of the STOP input	At the start of or during the manoeuvre, the STOP input was activated; identify the cause.
5 flashes 1 second pause 5 flashes	Error in the internal parameters of the electronic control unit	Wait at least 30 seconds, then try giving a command; if the condition persists it means there is a serious malfunction and the electronic board has to be replaced.
6 flashes 1 second pause 6 flashes	The maximum manoeuvre limit/hour has been exceeded	Wait for a few minutes until the manoeuvre limiting device drops to under the maximum limit.
7 flashes 1 second pause 7 flashes	There is an error in the internal electric circuits	Disconnect all the power circuits for a few seconds and then try to give the command again. If the condition persists it means there is a serious malfunction and the electronic board has to be replaced.
8 flashes 1 second pause 8 flashes	A command that does not permit other commands to be performed is already present	Check the type of command that is always present; for example, it could be a command from a timer on the "open" input.
9 flashes 1 second pause 9 flashes	The automation is locked	Release the automation by sending an automation release command to the control unit.

10.6.3 - Control unit

The control unit has a series of LEDs, each of which can give particular signals both during regular operation and when there is a problem, see **Table 13**.

TABLE 13 (fig. 40)

ECSBus LED [A]	Status	Action
Off The led flashes slowly	Malfunction	Make sure there is power supply; check to see if the fuses are blown; if necessary, identify the reason for the failure and then replace the fuses ones of the same type.
On	Serious malfunction	There is a serious malfunction; try switching off the control unit for a few seconds; if the condition persists, it means there is a malfunction and the circuit board has to be replaced.
One flash every second	All OK	Normal operation of control unit
2 long flashes	The status of the inputs has changed	This is normal when there is a change in one of the inputs: OPEN, STOP, triggering of photocells or the radio transmitter is in use.
1 flash every 5 seconds	Automation in "standby" mode	All OK; when a command arrives, the control unit will reset to normal functioning (after a brief delay).
Series of flashes separated by a pause	This is the same signal as on the flasher, see Table 12	An overload has been detected and therefore the power supply to the ECSBus has been turned off. Check, possibly by disconnecting each device one at a time.
Fast flashing	ECSBus short circuit	To switch on power to the ECSBus you simply need to give the command, for example, using the radio transmitter.
LED STOP [B]	Status	Action
Off *	Activation of the STOP input	Check the devices connected to the STOP input
On	All OK	STOP Input active
LED OPEN [C]	Status	Action
Off	All OK	OPEN input not active
On	OPEN input activation	Normal only if the device connected to the OPEN input is definitely active.

LED P1 [D]	Status	Action
Off *	All OK	No memorisation in progress.
On	Memorisation in Mode 1	During memorisation in mode 1, it is normal for it to take a maximum of 10 s.
Series of quick flashes, from 1 to 4	Memorisation in Mode 2	During memorisation in mode 2, it is normal for it to take a maximum of 10 s.
5 quick flashes	Cancellation OK	Completion of deletion of a transmitter.
1 slow flash	Wrong command	A command has been received from an unmemorised transmitter
3 slow flashes	Memorisation OK	Memorisation completed successfully
5 slow flashes	Cancellation OK	Completion of deletion of all transmitters.
LED P2 [E]	Status	Action
Off *	All OK	"Slow" speed selected
On	All OK	"Fast" speed selected
1 flash per second	The device recognition phase has not been carried out, or there are errors in the data saved	It is possible that there are faulty devices. Check and if necessary repeat the device recognition phase (see paragraph 10.3.3 "Recognition of other devices")
2 flashes per second	Devices recognition phase in progress	Indicates that it is in the process of recognising the attached devices (this will take a maximum of a few seconds)
LED P3 [F]	Status	Action
Off *	All OK	Cycle operation
On	All OK	Complete cycle operation
1 flash per second	There is no memorised opening angle	Carry out the recognition phase (see chapter "3.5.2 - Leaf open and closure angles recognition").
2 flashes per second	Opening angles auto-recognition phase in progress	Indicates that the open angles self-learning phase is in progress.

* or it could be in "Standby" mode

41

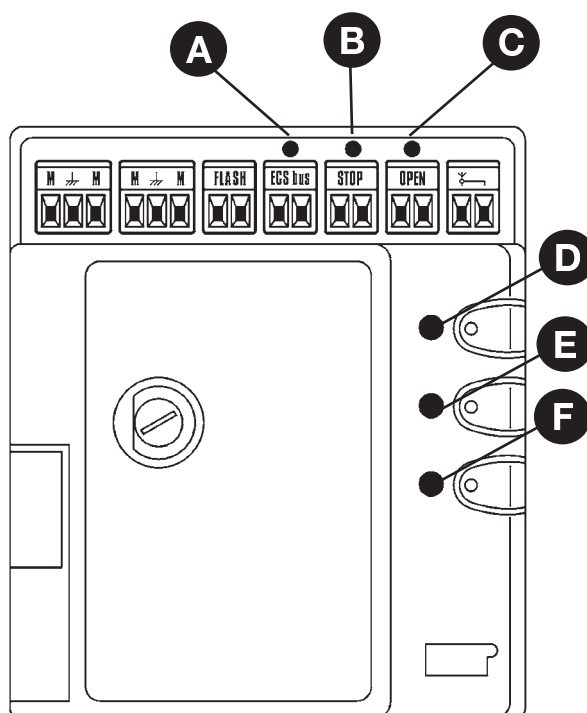

TECHNICAL SPECIFICATIONS OF PRODUCT COMPONENTS

WS200S is manufactured by NICE S.p.a. (prov. of Treviso – Italy). Nice S.p.a., in order to improve its products, reserves the right to modify their technical characteristics at any time without prior notice. In any case, the manufacturer guarantees their functionality and fitness for the intended purposes. Note: all the technical characteristics refer to a temperature of 20°C.

Model:	WS100SCK	WS100SK
Type	Electromechanical gearmotor for automation of automatic gates and doors with incorporated command control unit, complete with radio receiver for "GTX4" transmitters.	
Technology adopted	24Vdc motor, reducer with helical gears; mechanical release. A transformer inside the motor, but separate from the control unit, reduces the mains voltage to the nominal 24 V $\overline{\text{---}}$ voltage used in all of the automation system.	
Peak thrust	150 Nm	
Nominal torque	50 Nm	
Speed (no load)	1.7 RPM	
Nominal torque speed	1.4 RPM	
Maximum cycles frequency	20 cycles/hour at 50°C	
Maximum continuous cycle time	5 minutes	
Operating limits	The structural features make it suitable for use on gates with a weight of up to 150kg and a leaf length of up to 2.2 m. Opening angle of 110°	
Mains powered WS100SCK - WS100SK	230 V \sim (+10% -10%) 50/60Hz	24 Vdc
Nominal absorbed power	150 W; at peak the power is 250 W for a maximum duration of 1s	
Nominal absorbed current		2 A, at peak power the maximum current is 4 A for a maximum duration of 1s
Emergency power supply	Provision for "PR1" buffer battery	
FLASH output	For traffic lights: flashing light indicator lamp of 12 V maximum 21 W, Courtesy light lamp 24 V maximum 4 W, Gate open indicator lamp 24 V maximum 4 W	
ECSbus output	One output with maximum load of 15 ECSbus units	
"OPEN" input	For normally open contacts (the closing of the contact causes the "OPEN or Pedestrian Opening" command)	
"STOP" input	For normally closed or normally open contacts and/or for constant resistance of 8.2 K Ω , or normally closed contacts with self-recognition of the "normal" state (any variation from the memorised status causes the "STOP" command)	
Radio Antenna input	50 Ω for RG58 or similar type of cable	
Maximum cable length	Mains power supply: 30 m; inputs/outputs: 20 m with antenna cable preferably shorter than 5m (observe the warnings regarding minimum gauge and type of cables)	
Ambient operating temperature	-20 ÷ 50°C	
Use in acid, saline or potentially explosive atmospheres	NO	
Mounting	On a horizontal plane using the appropriate mounting plate	
Protection rating	IP54	
Dimensions / weight	237 x 155 x h 290 mm / 7 kg	237 x 155 x h 290 mm / 6.2 kg
Remote control compatibility	Using GTX4 transmitters, the control unit is able to receive one or more of the following commands: "OPEN", "Partial Open", "Open Only" and "Close Only"	
Memorisable GTX4 transmitters	This range can vary if there are obstacles or electromagnetic disturbances, and is affected by the position of the receiving aerial incorporated in the flasher	
Programmable functions	"Cycle" or "Complete cycle" (automatic closure) functionality "Slow" or "fast" motors speed Pause time during "complete cycle", selectable from 10, 20, 40, 80 seconds Partial opening type selectable in 4 modes Obstacle detection system sensitivity, 4 selectable levels "OPEN" command functionality selectable in 4 modes Open input configuration on the control unit: open or pedestrian opening FLASH output configuration: flashing light, courtesy light or gate open indicator Motors discharge on closure selectable from 8 levels Motors discharge on opening selectable from 8 levels	
Self-programming functions	Auto-recognition of devices connected to the ECSbus output Auto-recognition of the type of "STOP" device (NO or NC contact or 8.2 K Ω resistance) Recognition of the opening angle for each motor Automation recognition with 1 or 2 motors	

PH100 photocells (optional)

Type	Presence detector for automation of automatic gates and doors (type D in accordance with EN 12453) made up of a pair of a transmitter "TX" and a receiver "RX"
Technology adopted	Optical, via direct TX-RX interpolation with modulated infrared beam
Detection capacity	Opaque objects placed on the optical axis between TX-RX with dimensions greater than 50mm and a speed of below 1.6 m/s
TX transmission angle	approx. 20°
RX reception angle	approx. 20°
Useful range	Up to 10m for maximum $\pm 5^\circ$ TX-RX offset (the device can signal an obstacle even in the event of particularly adverse weather conditions)
Power supply/output	The device can be connected only to "ECSBus" networks, from which it obtains electrical power and sends the output signals
Absorbed power	1 ECSBus unit
Maximum cable length	Up to 20 m (observe the warnings regarding minimum gauge and type of cables)
Addressing capability	Up to 6 detectors with security features and 2 to control the open command Automatic synchronisation avoids interference between the various detectors
Ambient operating temperature	-20 ÷ 50°C
Use in acid, saline or potentially explosive atmospheres	No
Mounting	Vertical, wall-mounted
Protection rating	IP44
Dimensions / weight	64 x 89.2 h 29 mm / 60 g

FL100 signalling light (optional)

Type	Flashing indicator light for automatic gate and door automations The device incorporates a receiving antenna for remote control
Technology adopted	Illuminating indicator with 12V 21W lamp, controlled by the control units for automation supplied by Mhouse
Lamp	12V 21W BA15 fitting (self-moving lamp type)
Power input	The device may only be connected to the "FLASH" and "ANTENNA" terminals on Mhouse automation control units.
Ambient operating temperature	-20 ÷ 50°C
Use in acid, saline or potentially explosive atmospheres	No
Mounting	Horizontal on the ground or vertical on the wall
Protection rating	IP55
Dimensions / weight	120 x 60 h 170mm / 285g

GTX4 transmitters	
Type	Radio transmitters for remote control of automations for automatic gates and doors
Technology adopted	AM OOK radio encoded modulation
Frequency	433.92 MHz
Coding	Rolling code with 64 Bit code (18 billion, billion combinations)
Buttons	4, each key can be used for the various control unit commands or to command other control units
Radiated power	1mW approx.
Power input	3V +20% -40% with 1 lithium battery type CR2032
Battery life	3 years, estimated on the basis of 10 commands/day, each lasting 1s at 20°C (at low temperatures the efficiency of the batteries decreases)
Ambient operating temperature	-20 ÷ 50°C
Use in acid, saline or potentially explosive atmospheres	No
Protection rating	IP40 (suitable for use indoors or in protected environments)
Dimensions / weight	50 x 50 h 17mm / 16g

CE declaration of conformity

Declaration in accordance with the following Directives: 1999/5/EC (LVD), 2004/108/EC (EMC); 2006/42/CE (MD) annex II, part B

Note: - The contents of this declaration correspond to declarations in the official document filed in the offices of Nice S.p.a., and particularly the latest version thereof available prior to the printing of this manual. The text herein has been re-edited for editorial purposes. A copy of the original declaration can be requested from Nice S.p.A. (prov. of Treviso – Italy)

Declaration number: 476/WS200S

Revision: 0

Language: EN

Manufacturer's Name: NICE s.p.a.
Address: Via Pezza Alta 13, 31046 Rustignè di Oderzo (TV) Italy
Person authorized to draw up technical documentation: NICE S.p.A.
Product type: Electromechanical gearmotor and accessory equipment
Model / Type: WS100SC, WS100SK, GTX4, PH100, FL100
Accessories:

The undersigned Luigi Paro, as Managing Director, hereby declares under his own responsibility that the products identified above comply with the provisions of the following directives:

- The models WS100SC and GTX4 conform to Directive 1999/5/EC OF THE EUROPEAN PARLIAMENT AND OF THE COUNCIL of 9 March 1999 on radio equipment and telecommunications terminal equipment and the mutual recognition of their conformity, in accordance with the following harmonised standards:
 - Health and safety (Art. 3(1)(a)): EN 62479:2010
 - Electrical safety (Art. 3(1)(a)): EN 60950-1:2006+A11:2009
 - Electromagnetic compatibility (Art. 3(1)(b)): EN 301 489-1 V1.9.2:2011, EN 301 489-3 V1.4.1:2002
 - Radio spectrum (Art. 3(2)): EN 300 220-2 V2.3.1:2010

In accordance with Directive 1999/5/EC (appendix V), the GTX4 product is class 1 and marked: **CE 0682**

- Models WS100SC, WS100SK, PH100 and FL100 conform to DIRECTIVE 2004/108/EC OF THE EUROPEAN PARLIAMENT AND COUNCIL of December 15 2004 concerning alignment of Member States' legislation regarding electromagnetic compatibility and abrogating directive 89/336/EEC, according to the following harmonized standards: EN 61000-6-2:2005, EN 61000-6-3:2007

In addition, the WS100SC, WS100SK products conform to the following directive in accordance with the provisions applicable to partly completed machinery:

Directive 2006/42/EC OF THE EUROPEAN PARLIAMENT AND COUNCIL of May 17 2006 regarding machines and amending directive 95/16/EC (consolidated text)

- I hereby declare that the pertinent technical documentation has been drafted in accordance with Annex VII B of Directive 2006/42/EC and that the following essential requirements have been fulfilled:
 - 1.1- 1.1.2- 1.1.3- 1.2-1-1.2.6- 1.5.1-1.5.2- 1.5.5- 1.5.6- 1.5.7- 1.5.8- 1.5.10- 1.5.11
- The manufacturer agrees to send the national authorities pertinent information on the partly completed machinery, in response to a motivated request, without affecting its intellectual property rights.
- If the partly completed machinery is operated in a European country with an official language other than the language used in this declaration, the importer must include a translation with this declaration.
- The partly completed machinery must not be operated until the final machine in which it is to be incorporated is declared to conform to the provisions of Directive 2006/42/EC, if applicable.

The WS100SC and WS100SK products also comply with the following standards:
 EN 60335-1:2002 + A1:2004 + A11:2004 + A12:2006 + A2:2006 + A13:2008 + A14:2010 + A15:2011
 EN 60335-2-103:2003+A1:2009

The parts of the WS100SC and WS100SK products which are subject to the following standards comply with them:
 EN 13241-1:2003, EN 12445:2002, EN 12453:2002, EN 12978:2003

Oderzo, 31 July 2013

Mr. **Luigi Paro** (Managing Director)



— STEP 11 —

It is recommended to keep this guide and make it available to all users of the automation.

11.1 – Safety precautions

- Supervise the door in movement and keep at a safe distance until the door is fully open or closed; do not pass through the opening until the door is fully open and stopped.
- Do not let children play near the door or with its commands.
- Keep the transmitters away from children.

- Immediately discontinue use of the automation as soon as you notice any abnormal functioning (noises or jolting movements); failure to heed this warning may result in serious dangers and risks of injury.
- Do not touch any part while it is moving.
- Do perform periodic checks as provided for in the maintenance schedule.
- Maintenance or repairs must be carried out only by qualified technical personnel.

11.2 – Gate control

• With radio transmitter

The radio transmitter provided is already ready for use and the four keys have the following functions (fig. 42):

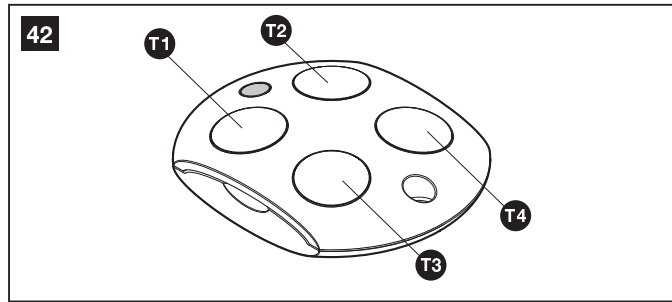

	Function(*)
T1 Key	
T2 Key	
T3 Key	
T4 Key	

(*) This table must be compiled by the person who programmed the automation.

• With selector switch (optional accessory)

The selector has two positions with automatic return to the centre (fig. 43).

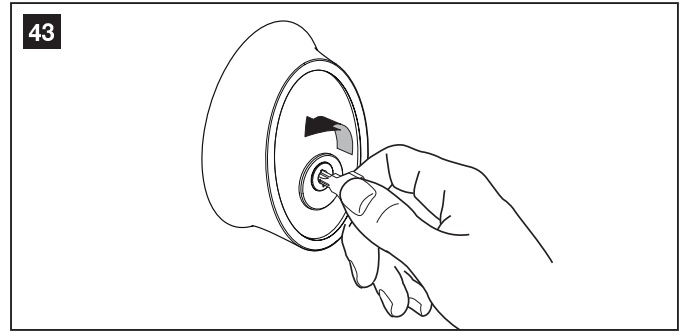

Action	Function
Rotated to the right: "OPEN"	(*)
Rotated to the left: "STOP"	Stops the door movement sectional or up-and-over

(*) This item must be compiled by the person who programmed the automation.

• Control with safety devices out of order

In the event of safety devices malfunctioning or being out of service, the door may still be moved.

01. Operating the gate control (with remote control or key selector switch). If the safety devices give consent the door opens normally; otherwise within 3 seconds you must try again and keep the control actuated.
02. After approximately 2s the door will start moving in the "man present" mode, i.e. so long as the control is maintained the gate will keep moving; as soon as the control is released the gate will stop.

If the safety devices are out of order the automation must be repaired as soon as possible.

11.3 – Manually releasing and locking the gearmotor (fig. 44)

WS100SK-WS100SCK are equipped with a mechanical system that allows you to open and close the gate manually (that is, as if the gearmotor were not present).

Manual operation must be used in the case of a power failure or in the event of a fault in the system. In the event of a power failure, you can use the buffer battery (optional accessory PR3).

In the event of a gearmotor fault, you can still try to use the motor release to check if the fault lies in the release mechanism.

01. Insert the key into the release pin.
02. Turn the key clockwise some 180° until you hear the gate release.
03. The gate can now be moved manually.
04. To restore automation functionality, turn the key anticlockwise while moving the gate, until you hear it latch.
05. Remove the key.

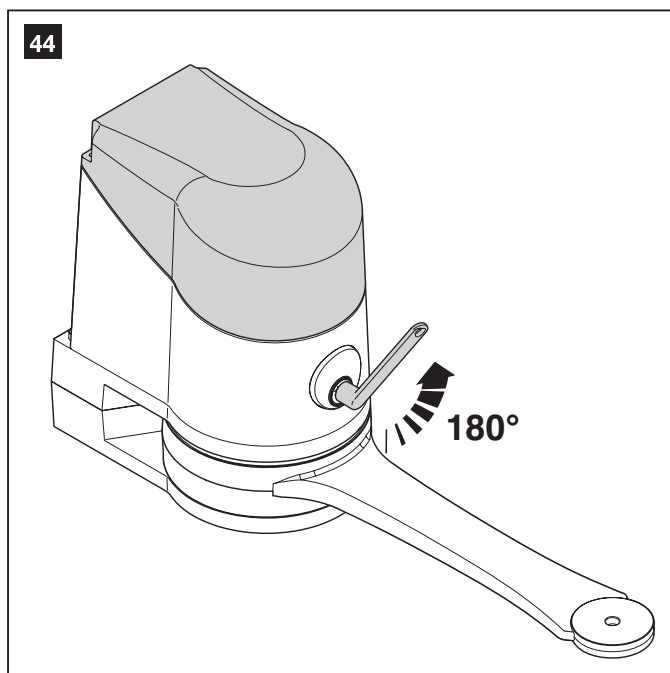

11.4 – User-admissible maintenance operations

Listed below are the operations that the user must perform periodically.

- Use a slightly damp cloth (not wet) for cleaning the surfaces of the devices. Never use substances containing alcohol, benzene, diluents or other flammable substances. Use of these substances may damage to the devices and cause fires or electric shocks.
- Remove power to the automation before removing leaves and stones, to ensure that no one can operate the door.
- Check the system periodically, in particular all cables, springs and supports to detect possible imbalance, signs of wear or damage. Do not use the automation if repairs or adjustments are required; any fault or an incorrectly balanced door may lead to physical injury.

11.5 – Remote control battery replacement (fig. 45)

When the battery is discharged, the transmitter capacity is significantly reduced. If, when a button is pressed, the led L1 turns on and immediately fades to off, it means that the battery is completely discharged and should be immediately replaced.

If, on the other hand, the led L1 turns on only for a moment, it means that the battery is partially discharged; it is necessary to hold the button down for at least half a second because the transmitter can attempt to send the command. However, if the battery level is too low to complete the command (and possibly wait for the response), the transmitter will turn off, with the led L1 that fades. In these cases, to restore normal transmitter operation, the battery must be replaced with a version of the same type, noting the polarity as specified.

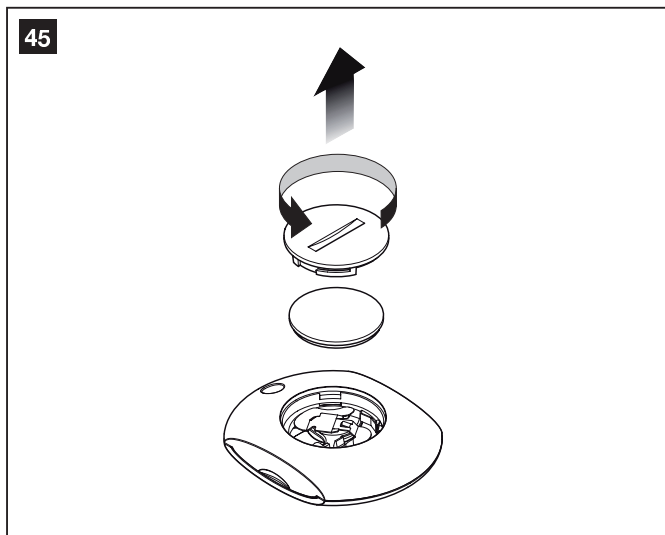

Batteries contain polluting substances: do not dispose of them together with other waste but use the methods established by local regulations.

11.6 – Remote control support installation

To install the remote control support see fig. 46.

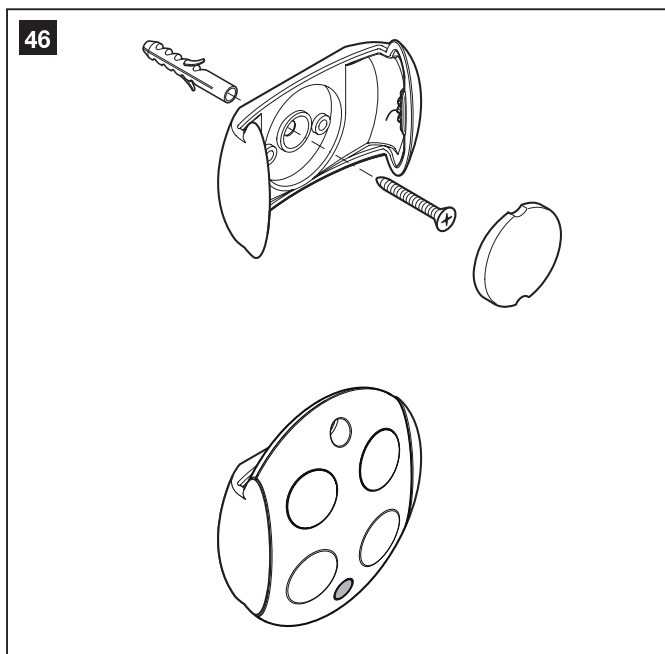

CE DECLARATION OF CONFORMITY

In conformity with Directive 2006/42/EC, Appendix II, part A (EC declaration of conformity for machinery)

The undersigned/company (*name or company name of whoever commissioned the motorised gate*):

.....

Address:

.....

Hereby declares under his/her sole responsibility that:

- **the automation:** hinged leaves motorised gate
- **Serial No.:**
- **Year of manufacture:**
- **Location (address):**

.....

Complies with the essential requirements of the following directives:

- 2006/42/EC** "Machines" Directive
- 2004/108/EEC** Directive on electromagnetic compatibility
- 2006/95/EEC** "Low voltage" Directive
- 1999/5/EC** R&TTE Directive

and as provided for in the following harmonised standards:

- EN 12445** "Industrial, commercial and garage doors and gates. Safety in use of Power-operated doors and gates – Test Methods"
- EN 12453** "Industrial, commercial and garage doors and gates. Safety in use of Power-operated doors and gates – Requirements"

Name: Signature:

Date:

Place:

