

MhouseKit SL1^S - SL10^S

CE

For automation of a sliding gate



Installation instructions and warnings, and User Manual

mhouse
4

CONTENTS

SAFETY WARNINGS AND GENERAL PRECAUTIONS

STEP 1	2
---------------	---

KNOWLEDGE OF THE PRODUCT AND PREPARATION FOR INSTALLATION

STEP 2	2
2.1 - PRODUCT DESCRIPTION AND INTENDED USE	2
2.2 - COMPONENTS USED TO SET UP A COMPLETE SYSTEM	3

PRELIMINARY CHECKS FOR INSTALLATION

STEP 3	3
3.1 - CHECKING SUITABILITY OF GATE TO BE AUTOMATED AND RELATIVE ENVIRONMENT	3
3.2 - PRODUCT APPLICATION LIMITS	3
3.3 - PRODUCT DURABILITY	3

STEP 4	4
4.1 - PRODUCT APPLICATION LIMITS	4
4.2 - PREPARING ELECTRIC CABLES	4

INSTALLATION: ASSEMBLY AND CONNECTION OF COMPONENTS

STEP 5	6
5.1 - INSTALLING THE GEARMOTOR ON THE GATE WITHOUT A RACK	6
5.2 - INSTALLING THE GEARMOTOR ON THE GATE WITH AN EXISTING RACK	6

STEP 6	10
6.1 - INSTALLING THE PH100 PHOTOCELLS	10
6.2 - INSTALLING THE KS100 KEY-OPERATED SELECTOR SWITCH	10
6.3 - INSTALLING THE FL100 FLASHING LIGHT	10
6.4 - ELECTRICAL CONNECTION TO CONTROL UNIT	10

PROGRAMMING

STEP 7	14
7.1 - POWER SUPPLY CONNECTION	14
7.2 - INITIAL CHECKS	14
7.3 - LEARNING CONNECTED DEVICES	14
7.4 - CHECKING GATE LEAF MOVEMENT	14
7.5 - CHECKING THE RADIO TRANSMITTERS	14
7.6 - SETTINGS	14

TESTING AND COMMISSIONING

STEP 8	16
8.1 - TESTING	16
8.2 - COMMISSIONING	16

MAINTENANCE

STEP 9	16
---------------	----

PRODUCT DISPOSAL	16
-------------------------	----

FURTHER INFORMATION

STEP 10	17
10.1 - ADVANCED SETTINGS	17
10.2 - OPTIONAL ACCESSORIES	17
10.3 - ADDING OR REMOVING DEVICES	19
10.4 - MEMORIZING ALL RADIO TRANSMITTERS	21
10.5 - TROUBLESHOOTING	22
10.6 - DIAGNOSTICS AND SIGNALS	22

TECHNICAL SPECIFICATIONS OF PRODUCT

COMPONENTS	25
-------------------	----

APPENDIX 1 - EC declaration of conformity	28
--	----

USER'S GUIDE

STEP 11	29
11.1 - SAFETY INSTRUCTIONS	29
11.2 - GATE CONTROL	29
11.3 - MANUALLY RELEASING OR LOCKING THE GEARMOTOR	29
11.4 - MAINTENANCE OPERATIONS ADMISSIBLE TO THE USER	30
11.5 - REMOTE CONTROL BATTERY REPLACEMENT	30
11.6 - INSTALL THE REMOTE CONTROL SUPPORT	30

APPENDIX 2 - EC declaration of conformity	31
--	----

SAFETY WARNINGS AND GENERAL PRECAUTIONS

— STEP 1 —

Safety warnings

- **CAUTION! – This manual contains important instructions and warnings for personal safety.** Incorrect installation could cause serious physical injury. Carefully read all parts of this manual before starting any work. If in doubt, suspend installation immediately and contact the Mhouse Technical Assistance.
- **CAUTION! – Important instructions: keep this manual in a safe place to enable future product maintenance and disposal procedures.**
- **CAUTION! - According to the most recent European legislation, the production of a power-operated door or gate must comply with the standards envisaged in the Directive 2006/42/EC (Machinery Directive) and in particular standards EN 12445; EN 12453; EN 12635 and EN 13241-1, which enable declaration of presumed conformity of the automation. In consideration of this, all mains connection, testing commissioning and maintenance operations must be performed exclusively by a qualified and skilled technician!**
All preliminary set-up, installation and programming operations may be performed by personnel with standard skills, provided that all instructions and the relative sequences in this manual are strictly observed, with particular reference to the warnings in this STEP 1.

Installation warnings

While reading this manual, take care to observe all instructions marked with the following symbol:



These symbols indicate subjects that may be the source of potential hazards and therefore the prescribed operations **must be performed exclusively by qualified and skilled personnel, in observance of these instructions current safety standards.**

- Before installation, ensure that this product is suitable for automation of your gate or door (see STEP 3 and chapter “Product Technical Specifications”). If not suitable, do NOT proceed with installation.
- On the system power mains install a device for disconnection (not supplied), to guarantee a gap between contacts and complete disconnection in the conditions of overvoltage category III.
- **All installation and maintenance operations must be performed with the automation disconnected from the power supply.** If the power disconnect device is not visible from the location of the automation, before work a notice should be affixed on the disconnect device, with the text “CAUTION! MAINTENANCE IN PROGRESS”.
- **CAUTION! - Never power up the motor before fully installed on the column and leaf of the gate.**
- During installation, handle the automation with care, avoiding the risk of impact, dropping or contact with any type of liquid. Never place the product near to sources of heat and never expose to naked flames. This may damage product components and cause malfunctions, fire or hazardous situations. If this occurs, suspend installation immediately and contact the MhouseTechnical Assistance.

- Never make modifications to any part of the product. Operations other than as specified can only cause malfunctions. The manufacturer declines all liability for damage caused by makeshift modifications to the product.
- If the power cable is damaged, it must be replaced exclusively by a qualified technician, to avoid potential risks.
- Connect the control unit to an electric power line equipped with an earthing system.
- This product is not designed to be used by persons (including children) whose physical, sensorial or mental capacities are reduced, or with lack of experience or skill, unless suitable instructions regarding use of the product have been provided by a person responsible for safety.
- The key-operated selector switch must be positioned in sight of the automation, but far from moving parts and at a height of at least 1.5 m from the ground, not accessible by the public. If this is used in “hold-to-run” mode, ensure that there are no persons in the vicinity of the automation.
- In the vicinity of the automation children must be supervised to ensure that they do not play with it.
- Ensure that there are not points of entrapment or crushing with fixed parts when the gate leaf is in the maximum opening or closing position; protect parts if necessary.
- The product may not be considered an efficient system of protection against intrusion. If an efficient protection system is required, the automation must be integrated with other safety devices.
- The automation must not be used before performing the commissioning procedure as specified in the chapter “Testing and commissioning”.
- Check the automation frequently to ensure there is no imbalance, signs of wear or damage to electrical or mechanical parts. Do not use the automation if adjustments or repairs are necessary.
- In the event of long periods of disuse, to avoid the risk of leaks of harmful substances from the optional battery (PR1) disconnect it from the automation and store in a dry location.
- Do not allow children to play with fixed control devices. Keep remote control devices out of reach of children.
- The product’s packaging materials must be disposed of in full compliance with local regulations.

Operation warnings

- For cleaning the product surfaces, use a soft damp cloth. Use water only; never use detergents or solvents for cleaning.

KNOWLEDGE OF THE PRODUCT AND PREPARATION FOR INSTALLATION

NOTES TO MANUAL

- This manual describes how to set up a complete and optimal automation, such as that shown in fig. 3, using all Mhouse devices that are part of the automation system named “SL1S-SL10S”. Some of these devices are optional and may not be present in the kit. For a complete overview of the devices, refer to the Mhouse product catalogue.
- This manual has been drawn up as a **step-by-step guide**. Therefore, to ensure safe and facilitated assembly and programming procedures, perform all operations described in the same order as specified in this document.

— STEP 2 —

2.1 - PRODUCT DESCRIPTION AND INTENDED USE

The devices in this kit, plus other accessories (some optional and not included in the pack), form the automation system named “SL1S-SL10S”, designed for the automation of a “residential” sliding gate. **Any other use than as specified herein or in environmental conditions other than as stated in this manual is to be considered improper and is strictly prohibited!**

The main part of the automation comprises an electromechanical gear-motor, fitted with a 24 V dc motor with helical teeth gear; it is fitted with a mechanical key release which enables manual movement of the gate in the event of a power failure. The gearmotor is equipped with a control unit that manages operation of the entire automation. The control unit comprises a board and incorporated radio receiver which receives the

commands sent by the user via a transmitter. It can memorise up to 256 GTX4 transmitters (if memorised in "Mode I") and up to 6 pairs of PH100 photocells.

Connection of the control unit with the various devices is by means of a single 2-wire cable ("ECSbus" system). The control unit can also be mains-powered (230 V) or alternatively by the Mhouse PF photovoltaic system.

If mains-powered, it can house a buffer battery (mod. PR1, optional accessory) which guarantees a number of manoeuvres, during the hours following a mains power failure). During the power failure, or at any other time, the gate leaf can be moved manually if required, by first releasing the gearmotor using the relative key (see chapter 11.3 - User's Guide).

2.2 - COMPONENTS USED TO SET UP A COMPLETE SYSTEM

Fig. 1 illustrates all components used to set up a complete system, such as that shown in fig. 3.

Components shown in fig. 1:

A - 1 electromechanical gearmotor SL1SC/SL10SC with integrated control unit and foundation plate

B - 2 limiter brackets

C - 3 release keys

D - 1 pair of PH100 photocells (one TX and one RX)

E - 2 GTX4 radio transmitters

F - 1 FL100 flashing light with integrated aerial

G - Metal hardware

Notes:

- Some devices and accessories specified in the manual are optional and may not be present in the kit. For a complete description, refer to the Mhouse product catalogue or visit the website.

- The mechanical limit stops are not supplied in the pack and are not part of the Mhouse product range.

— STEP 3 —

PRELIMINARY CHECKS FOR INSTALLATION

3.1 - CHECKING SUITABILITY OF GATE TO BE AUTOMATED AND RELATIVE ENVIRONMENT

- Ensure that the mechanical structure of the gate complies with current national standards and that it is suitable for automation. For this check, refer to the information specified on the gate dataplate. **Important** - This product cannot be used to automate a gate that is not already efficient and safe; furthermore it cannot solve defects caused by incorrect gate installation or poor maintenance.
- Manually move the gate in both directions (opening/closing) and ensure that friction is constant throughout travel (there must be no points of increased or decreased force).
- If the leaf is fitted in a pedestrian pass door or a door onto the leaf movement area, ensure that this door does not obstruct normal travel, and install a suitable interlock device if necessary.
- Manually move the gate to any position; leave it stationary and ensure that it does not move when left.
- Ensure that there is no risk of gate derailing or risks of exit from the tracks.
- Ensure that the space around the site of gearmotor installation enables safe and easy manual gate release.

- Make sure that the area where the gearmotor is fixed is not subject to flooding. If necessary, mount the gearmotor raised from the ground.
- Ensure that the selected surfaces for installation of the various devices are solid and guarantee a stable fixture; as regards photocells, select a flat surface that guarantees correct alignment between photocells (Tx and Rx).
- Ensure that all devices to be installed are in a sheltered location and protected against the risk of accidental impact.

3.2 - PRODUCT APPLICATION LIMIT

Before proceeding with installation, perform the following checks in the specified sequence and ensure conformity both with the data in this paragraph and the technical data provided in the chapter "Technical Specifications":

01. Ensure that the dimensions and weight of the gate are within the following limits of use:

SL1SC - maximum length 5 m
- maximum weight 400 kg

SL10SC - maximum length 7 m
- maximum weight 550 kg

02. Check the overall dimensions of the gearmotor (fig. 2). *Note* - These measurements also serve as a reference to calculate the space occupied by the foundation pit for routing the electrical cable ducting.
03. Ensure that the estimated lifetime is compatible with the intended use (see paragraph 3.3).
04. Ensure that all limits, conditions and warnings in this manual can be observed.

3.3 - PRODUCT DURABILITY

The lifetime is the average economic duration of the product. The value of lifetime is strongly influenced by the intensity of the manoeuvres, i.e. the sum of all factors that contribute to product wear, see Table 1. To estimate the durability of your automation, proceed as follows:

01. Add up all the values in the items of **Table A**;
02. In **Graph 1** from the value obtained above, trace vertical line until it intersects the curve; from this point trace a horizontal line until it intersects the line of the "manoeuvre cycles". The value obtained is the estimated lifetime of your product.

The lifetime values specified in the graph are only obtainable if the maintenance schedule is strictly observed (see chapter 9 - Maintenance schedule). The estimation of lifetime is made on the basis of design calculations and the results of tests performed on prototypes. As it is only an estimation, it does not represent any form of guarantee on the effective lifetime of the product.

Example of calculating lifetime: automation of a gate with a leaf length of 3.5 m with weight of 250 kg, for example, in a location near the sea. Table 1 states the "severity index" values for this type of installation: 10% ("Leaf length"), 20% ("Leaf weight") and 15% ("Presence of dust, sand or brine"). These values must be added up to obtain the overall severity index, which in this case is 45%.

TABLE A

		Severity index	
		SL1SC	SL10SC
Leaf length	< 3 m	0%	0%
	3 - 4 m	10%	5%
	4 - 5 m	20%	10%
	5 - 6 m	-	15%
	6 - 7 m	-	20%
Leaf weight	< 200 kg	10%	0%
	200 - 300 kg	20%	10%
	300 - 400 kg	30%	20%
	400 - 550 kg	-	30%
Ambient temperature over 40°C or lower than 0°C or humidity greater than 80%		20%	20%
Solid leaf		15%	15%
Installation in windy zone		15%	15%

Note - The data are based on a sliding gate balanced and in perfect condition maintenance

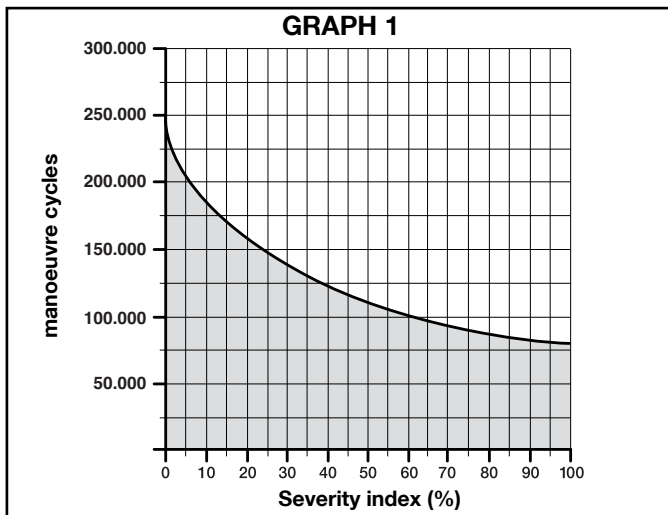

— STEP 4 —

4.1 - PRELIMINARY CHECKS FOR INSTALLATION

4.1.1 - Establish the position of devices in the system

With reference to **fig. 3** and **4**, locate the approximate position for installation of each device envisaged in the system. **Fig. 3** shows a system made using this product and other optional accessories in the Mhouse range. These elements are positioned according to a typical standard layout. The components are:

- a** - SL1SC/SL10SC gearmotor with control unit
- b** - Pair of PH100 photocells
- c** - FL100 flashing light with integrated aerial
- d** - Pair of posts for PT50 photocells (not supplied)
- e** - Closure mechanical stops
- f** - Floor-mounted track
- g** - "Opening" limiter bracket
- h** - CR100 rack (not supplied)
- i** - KS100 key-operated selector switch
- l** - "Closing" limiter bracket

WARNING! - Some of these devices are optional and may not be present in the kit (see Mhouse product catalogue).

WARNINGS:

- The gearmotor must be anchored to the ground, laterally to the gate using the relative fixing plate.
- The fixed control devices must be positioned:
 - in sight of the automation;
 - far from moving parts;
 - at a height of at least 1.5 m from the ground,
 - not accessible by the public.

4.1.2 - Establish the position of all connection cables

Refer to the instructions in paragraph 4.2 to establish the layout of the raceways for electric cable ducting.

4.1.3 - Ensure all equipment and materials for work are available

Before starting work, ensure that you have all equipment and materials required to complete the work. Ensure that all items are in good condition and comply with local safety standards.

4.1.4 - Completing the set-up work

Prepare the area for subsequent installation of the devices, completing all preliminary work, such as:

- digging of raceways for protection ducting of electric cables (external ducting may be used as an alternative);
- laying of protection ducting and embedding in concrete;
- sizing of all electric cables to required length (see paragraph 4.2) and routing in protection ducting. **Caution! - In this phase, do not make any electrical connections.**

Warnings:

- The hoses and ducting serve to protect electrical cables and prevent accidental damage in the event of impact.
- When laying pipelines, take into account the risk of possible deposits of water in the branch wells, where condensate may form in the pipelines and the control unit with possible damage to the electronic circuits.
- Position the ends of the ducting at the points envisaged for fixture of the various components.

4.2 - PREPARING ELECTRIC CABLES

To prepare all connection cables, proceed as follows.

- a)** - Refer to **fig. 4** to check the connections of the various devices to the control unit and terminals to be used for each connection. **Important** - Only devices using "ECSbus" technology can be connected to the terminal "ECSbus".
- b)** - Refer to **fig. 3** to check positions of the electrical cables in the area. Then draw a similar diagram on paper, adapting it to specific requirements of your system. **Note** - This diagram will be useful to establish the route of the raceways for cable ducting, and to draw up a complete list of the cables required.
- c)** - Read **Table 1** to determine the type of cables to be used; then refer to the diagram drawn above and on-site measurements to determine the length of each cable. **Caution! - No cable must exceed the specific maximum length stated in Table 1.**

WARNING - "ECSbus" technology enables the interconnection of devices using a single "bus" cable, with 2 internal electrical wires. Connection of several devices can be in the configuration "cascade", "star" or the latter two "combined":

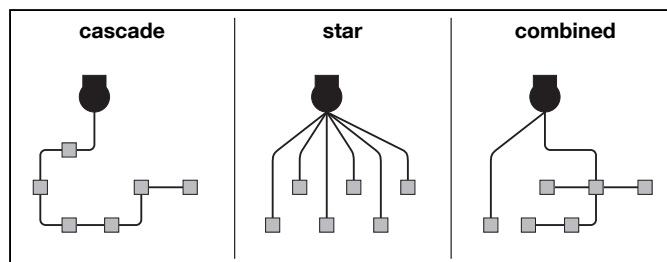

TABLE 1 – Technical specifications of electric cables

Connection	Type of cable (minimum section values)	Max. admissible length
A - Power line	Cable 3 x 1,5 mm ²	30 m (note 1)
B - FLASH flashing light output	Cable 2 x 0,5 mm ²	20 m
C - Radio aerial	RG58 shielded cable type	20 m (less than 5 m recommended)
D - Input/Output ECSbus	Cable 2 x 0,5 mm ²	20 m (note 2)
E - STOP input	Cable 2 x 0,5 mm ²	20 m (note 2)
F - OPEN input	Cable 2 x 0,5 mm ²	20 m (note 2)

Note 1 - If the power cable is longer than 30 m, a cable with a larger section is required (e.g. 3 x 2.5 mm²) and safety earthing is necessary in the vicinity of the automation.

Note 2 - For cables of ECSbus and those of the STOP and OPEN inputs, a single cable with multiple internal wires may be used, to combine several connections: for example, the STOP and OPEN inputs can be connected to the KS100 selector switch with a cable of 4 x 0.5 mm².

ATTENZIONE! – The cables used must be suited to the installation environment: for example a cable type H03VV-F is recommended for indoor environments, and a cable type H07RN-F for outdoor environments is recommended.

1

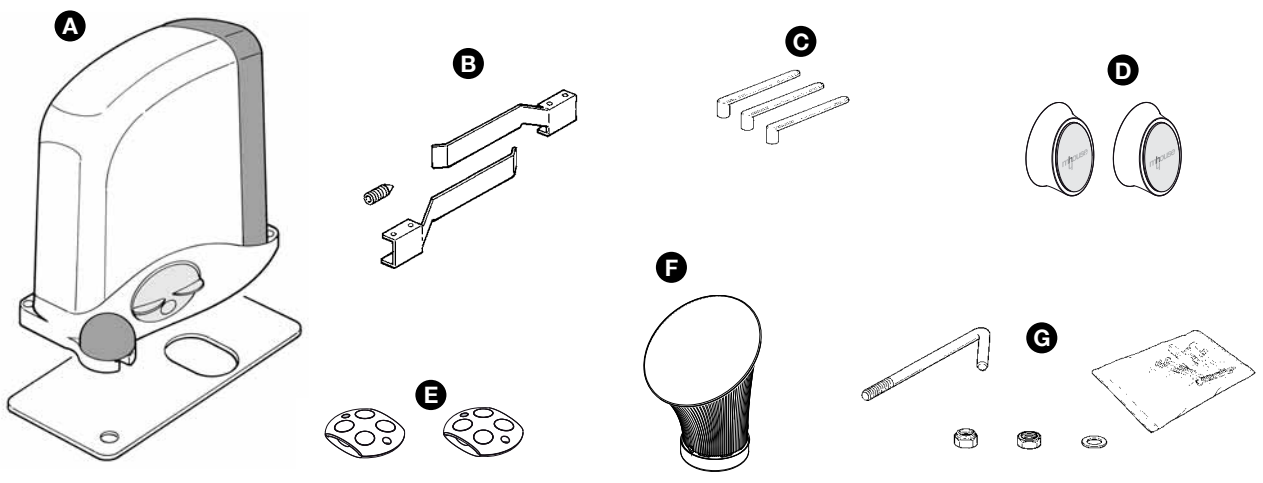

2

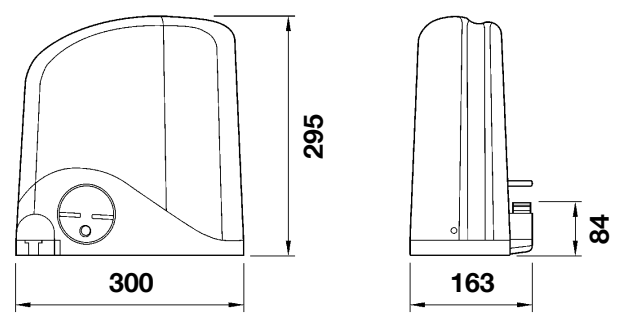

3

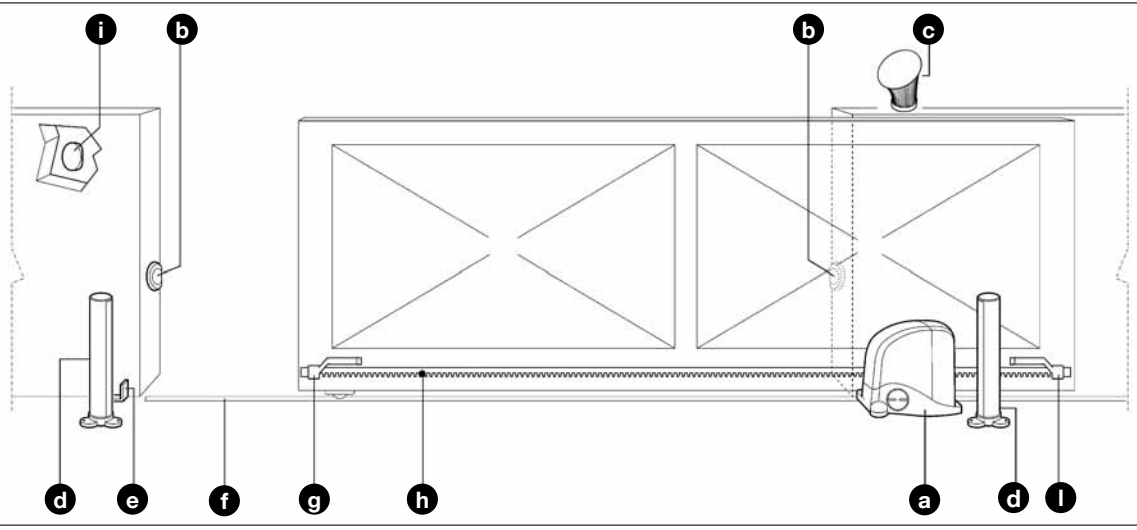

4

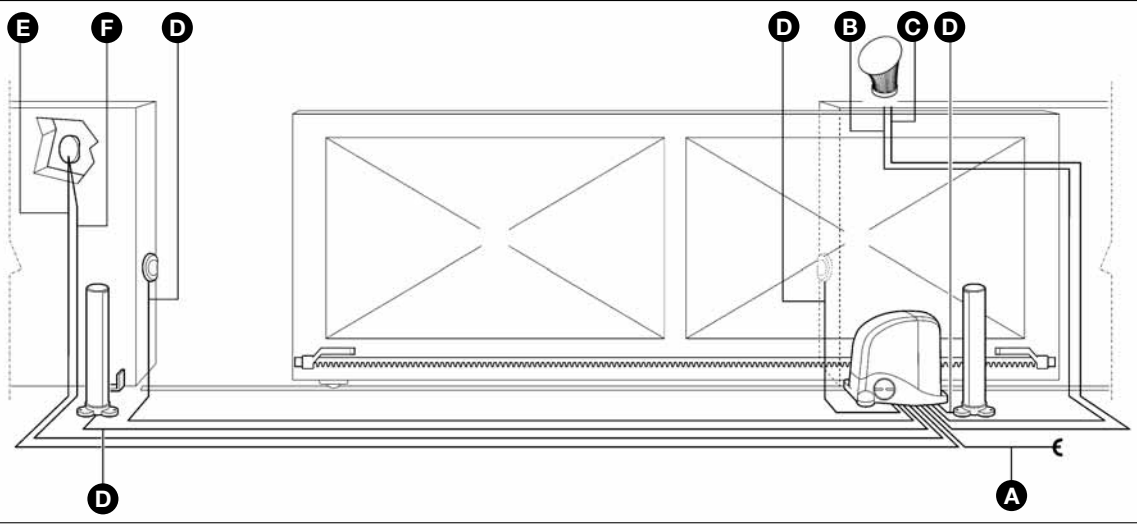

— STEP 5 —

IMPORTANT!

- The following assembly phases show installation of a gearmotor model SL15C/SL10SC.
 - To ensure correct system operation, mechanical stops must be mounted on the floor or wall at the maximum leaf opening and closing points. **Note** - These stops are not supplied in the pack and are not part of the Mhouse product range.

WARNINGS

- **Incorrect installation may cause serious physical injury to those working on or using the system.**
- **Before starting automation assembly, make the preliminary checks as described in STEP 3.**

5.1 - INSTALLING THE GEARMOTOR ON THE GATE WITH-OUT A RACK

If the support surface already exists, the gearmotor should be fixed on it directly, using suitable means, such as expansion plugs. Otherwise, to secure the gearmotor, proceed as follows:

01. Make a suitably-sized foundation pit, according to the required site of installation; see values shown in **fig. 2**;
 02. Prepare one or more duct tubes for routing the electric cables (**fig. 5**). *Note - Leave tubes longer than 50 cm;*
 03. Fit two bolts on the foundation plate placing a nut below and above the plate; the nut below the plate should be tightened as shown in **fig. 6** so that the threaded section protrudes by approx. 36 mm above the plate;
 04. Before casting the concrete, prepare the foundation plate with the printed side (position of pinion) facing the gate and positioned as specified by the values in **fig. 7**; then lay the tubes for routing the cables through the relative hole;
 05. Now cast the concrete and place the plate as described in point 04, ensuring that it is parallel to the leaf and perfectly level (**fig. 8**). Wait for the concrete to set completely;
 06. When the concrete is sufficiently dry (after a few days), remove the 2 upper nuts which will no longer be used;
 07. Shorten the cable routing tubes by 30/40 mm;
 08. Remove the nut cover on the gearmotor (**fig. 9**);
 09. Rest the gearmotor on the plate, ensuring that it is perfectly parallel to the leaf, then slightly lighten the 2 locknuts and washers supplied (**fig. 10**). Tighten the nuts fully down;
 10. Manually release the gearmotor (see paragraph 11.3 – User’s guide);
 11. Move the gate to the maximum opening position then position the first section of the rack above the pinion of the gearmotor. The rack should protrude, with respect to the axis of the pinion, by the value specified in **fig. 11** (with motor fixed to left) or **fig. 12** (with motor fixed to right); i.e. the space required for the limit switch brackets;
- Important!** – Leave a clearance of 1 mm between the rack (for all parts) and the pinion (**fig. 13**), so that the weight of the leaf does not exert pressure on the motor.
12. Now fix the other parts of the rack one after the other; to keep the rack aligned with the level of the pinion, simply trace the fixing hole when the slot is aligned with the axis of the pinion (**fig. 14**). Repeat the same operation at each fixing point;
 13. After fixing the last part of the rack, if necessary, cut off the protruding section; the rack should not protrude from the leaf;
 14. Manually complete a number of leaf opening and closing cycles to ensure that the rack slides smoothly along the pinion throughout the entire length;
 15. Position (approximately) the two **[A]** limit switch brackets on the rack (**fig. 15**) and manually move the gate for final fixture.
 16. Fix the limit switch brackets as follows:
 - a) manually move the leaf to the opening position, leaving a distance of at least 2-3 cm from the mechanical end stop.
 - b) slide the travel limit bracket on the rack in the opening direction until the limit switch trips. Then move the bracket forward by at least 2 cm and lock on the rack using the grub screws supplied.
 - c) perform the same operation to secure the closing limit switch.
 17. Manually lock the gearmotor (see paragraph 11.3 - User’s guide).

The electrical connections can now be made (see paragraph 6).

5.2 - INSTALLING THE GEARMOTOR ON THE GATE WITH AN EXISTING RACK

If the support surface already exists, the gearmotor should be fixed on it directly, using suitable means, such as expansion plugs. Otherwise, to secure the gearmotor, proceed as follows:

Warnings

- Before fixing the gearmotor, ensure that the existing rack is compatible with the overall dimensions of the pinion (see **fig. 16**).
- Ensure that the distance between the pinion and rack is approx. 12 mm.

01. Make a suitably-sized foundation pit, according to the required site of installation; see values shown in **fig. 2**; **Caution!** – The foundation plate must be positioned at 77 mm from the rack.
02. Fit one or more tubes for routing the electric cables (**fig. 5**). *Note - Leave tubes longer than 50 cm;*
03. Fit two bolts on the foundation plate placing a nut below and above the plate; the nut below the plate should be tightened as shown in **fig. 6** so that the threaded section protrudes by approx. 36 mm above the plate;
04. Before casting the concrete, prepare the foundation plate with the printed side (position of pinion) facing the gate and positioned as specified by the values in **fig. 17**; then lay the tubes for routing the cables through the relative hole;
05. Now cast the concrete and place the plate as described in point 04, ensuring that it is parallel to the leaf and perfectly level (**fig. 8**). Wait for the concrete to set completely;
06. When the concrete is sufficiently dry (after a few days), remove the 2 upper nuts which will no longer be used;
07. Shorten the cable routing tubes by 30/40 mm;
08. Remove the nut cover on the gearmotor (**fig. 9**);
09. Place the gearmotor on the foundation plate, tilting it to facilitate insertion below the rack (**fig. 18**). Slightly tighten the 2 locknuts, after inserting the washers;
10. If necessary, adjust the gearmotor height (max. 10 mm), using the 4 stud bolts fitted (**fig. 19**). **Important!** – Leave a clearance of 1 mm between the rack and the pinion, so that the weight of the leaf does not exert pressure on the motor.
Where possible, fix the gearmotor without stud bolts, to ensure increased stability and solid fixture on the plate;
11. Ensure that the gearmotor is perfectly parallel to the leaf, then fix it to the foundation plate, tightening the 2 locknuts fully down;
12. Manually release the gearmotor (see paragraph 11.3 - User’s guide);
13. Manually complete a number of leaf opening and closing cycles to ensure that the rack slides smoothly along the pinion throughout the entire length;
14. Fix the **[A]** limit switch brackets (**fig. 15**) as follows:
 - a) manually move the leaf to the opening position, leaving a distance of at least 2-3 cm from the mechanical end stop.
 - b) slide the travel limit bracket on the rack in the opening direction until the limit switch trips. Then move the bracket forward by at least 2 cm and lock on the rack using the grub screws supplied.
 - c) perform the same operation to secure the closing limit switch;
15. Manually release the gearmotor (see paragraph 11.3 - User’s guide).

The electrical connections can now be made (see paragraph 6).

5

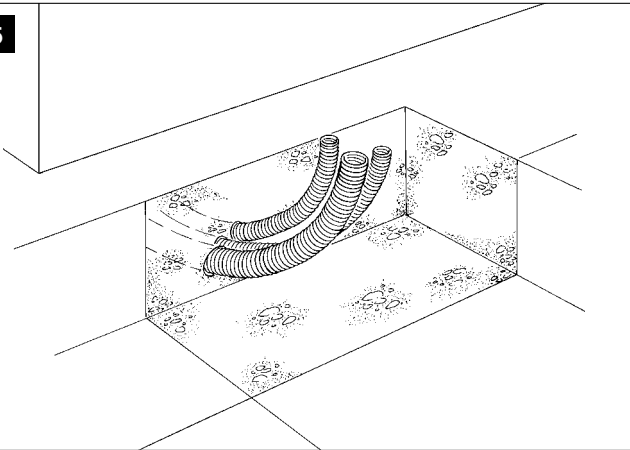

6

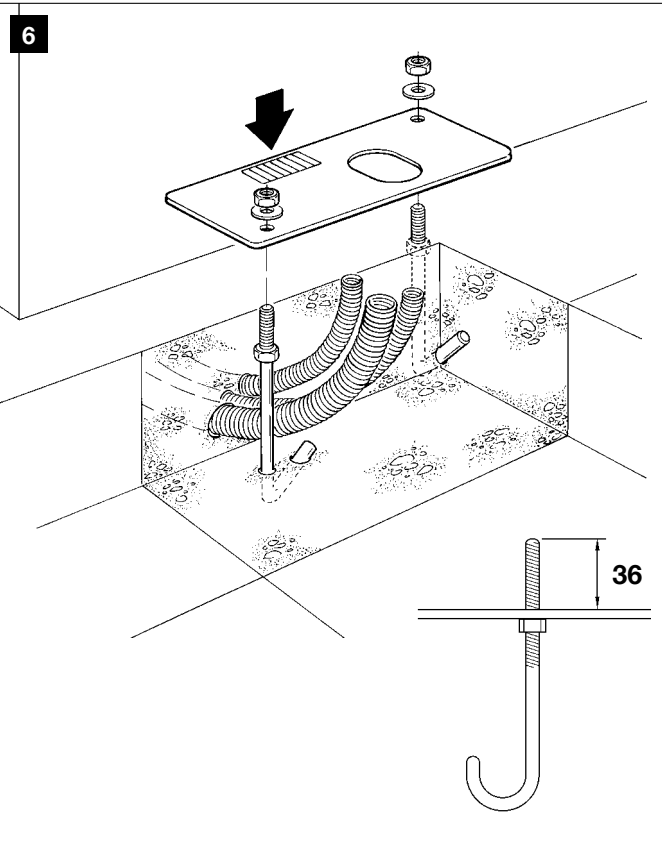

7 motor fixed on left

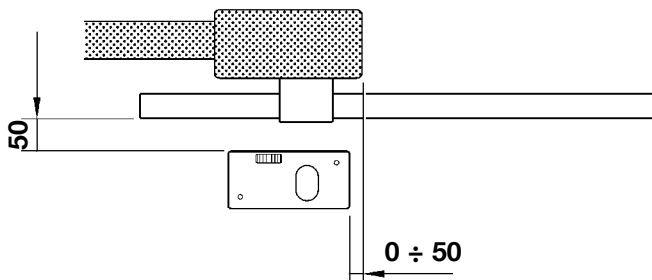

motor fixed on right

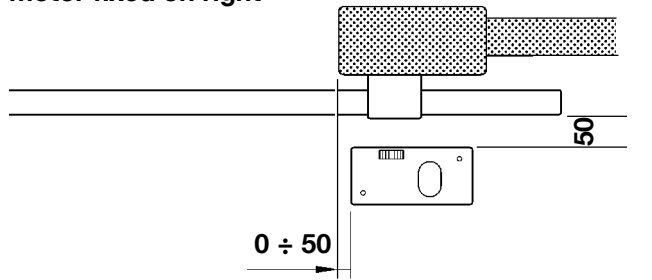

9

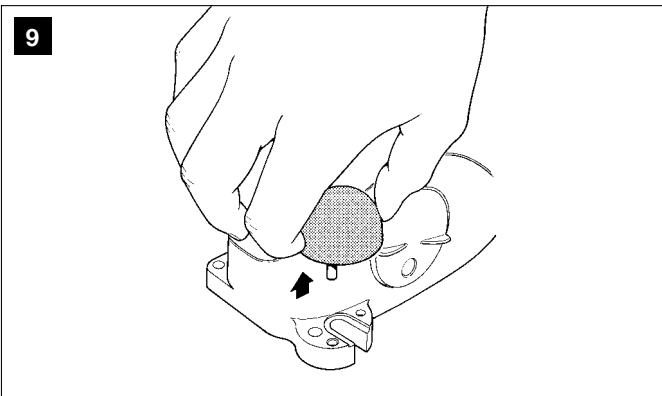

8

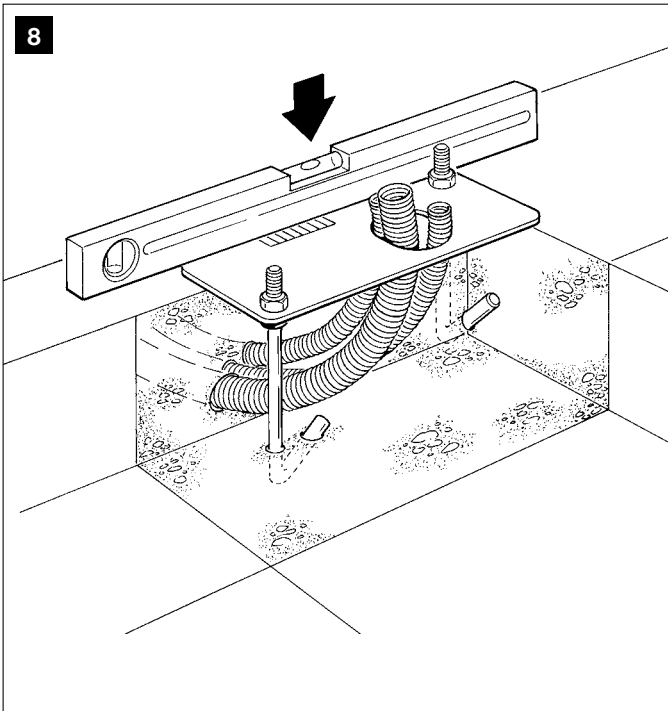

10

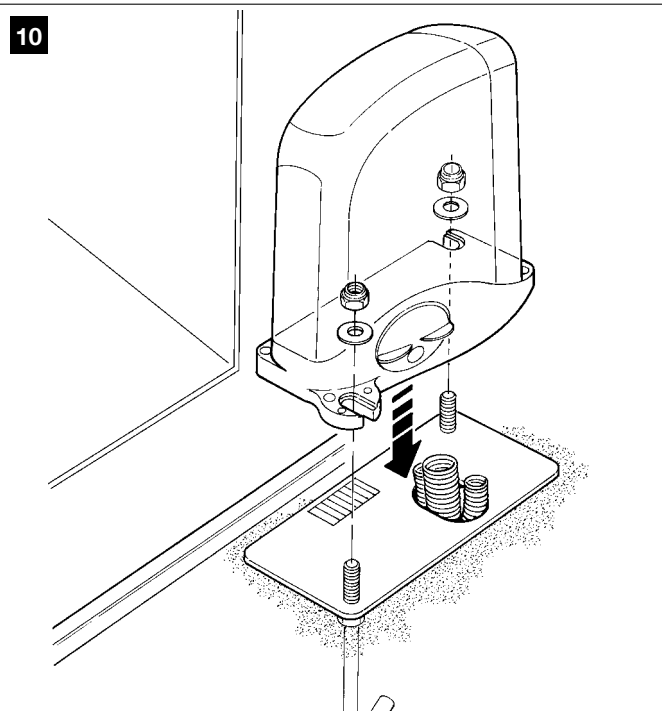

11

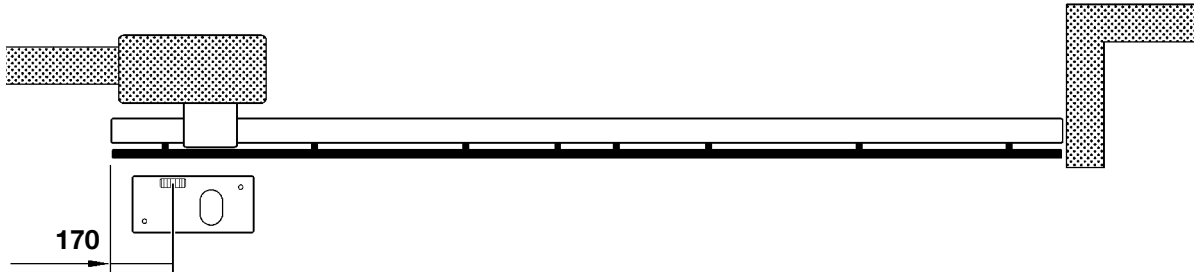

12

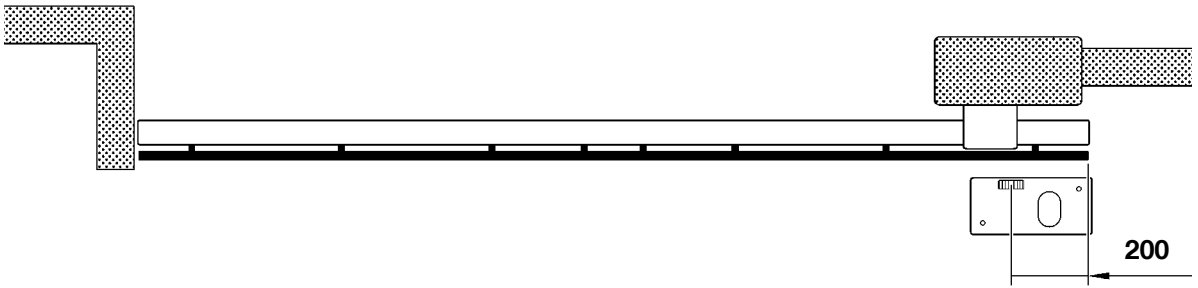

13

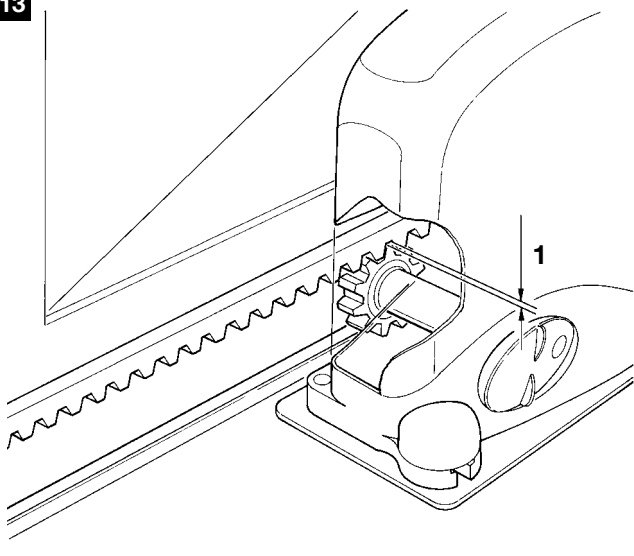

14

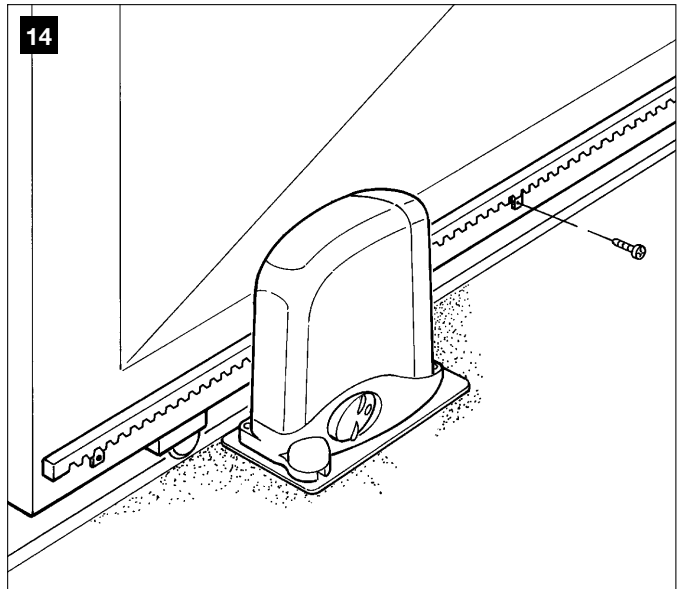

15

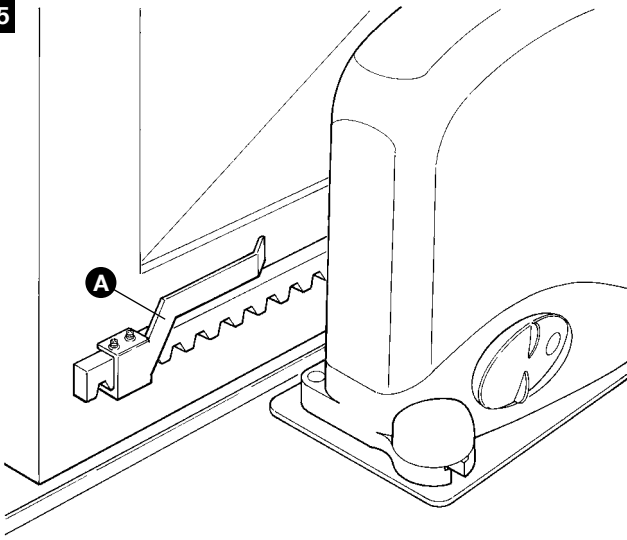

16

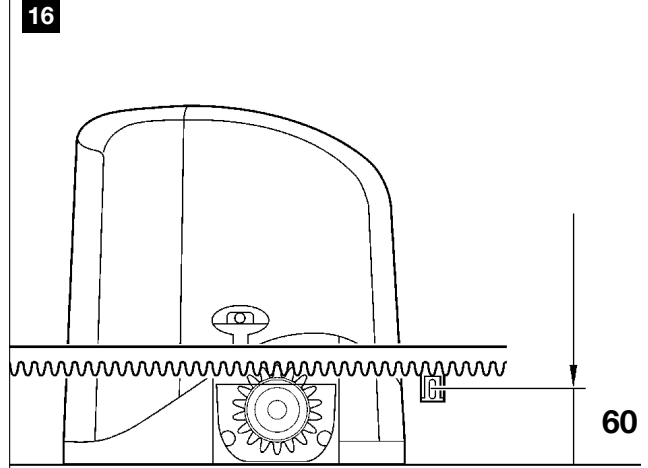

17 motor fixed on left

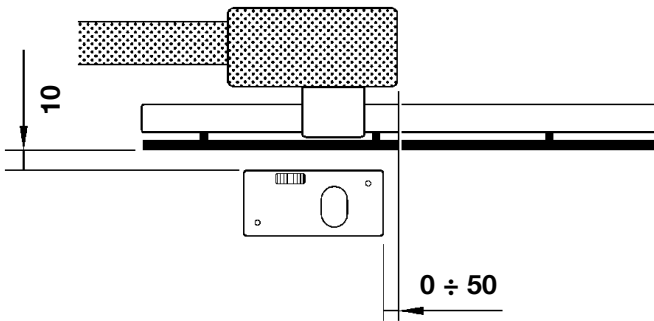

motor fixed on right

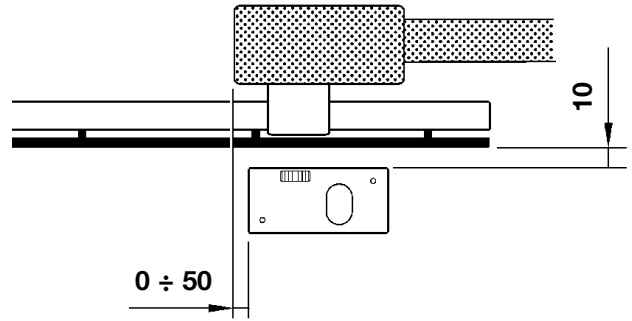

18

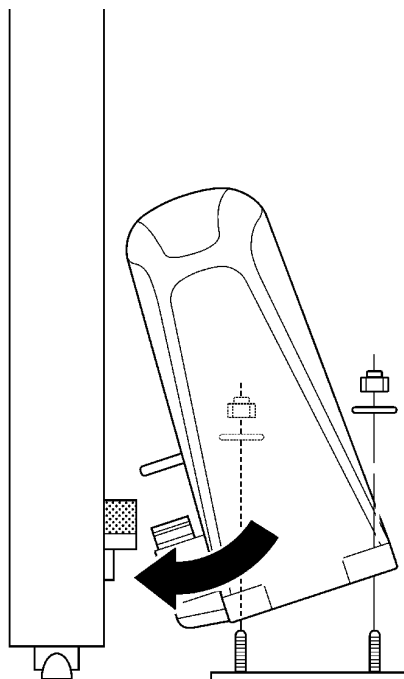

19

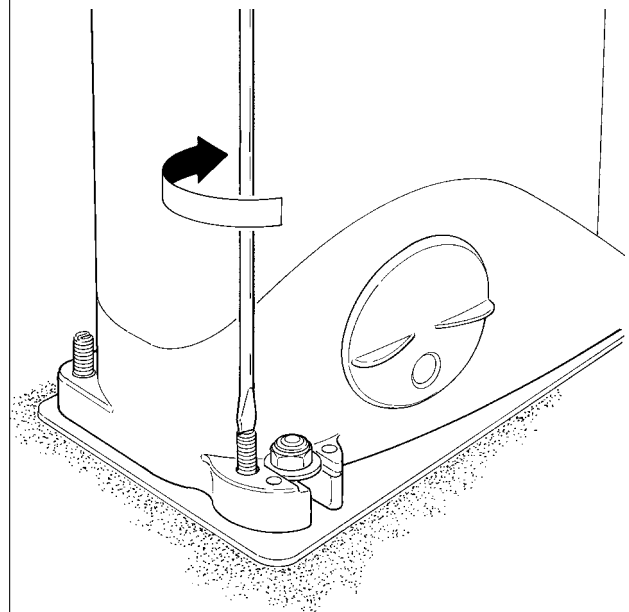

— STEP 6 —

6.1 - INSTALLING THE PH100 PHOTOCELLS (fig. 20)

Warning: all installation operations must be performed with the system disconnected from the power supply; if fitted, the PR1 backup battery must also be disconnected.

Warnings: Take care not to damage the o-ring fitted (fig. 20-3) [A].

Select the position of the two elements making up the photocell (TX and RX) observing the following:

- Place them at a height of 40-60 cm from the ground, to the sides of the zone to be protected, and as close as possible to the edge of the gate, i.e. no further than 15 cm.

- There must be a raceway tube at the point envisaged for routing cables.
- Point the transmitter TX at receiver RX with a maximum tolerance of 5°.

01. Remove the front glass panel (fig. 20-1).
02. Position the photocell at the point where the cable routing tube arrives.
03. Trace the drilling points using the base as a reference. Use a percussion drill to drill the wall, with a 5 mm tip, and insert 5 mm plugs.
04. Route the electric cables through the specific holes (pierce those required): see fig. 20-2.
05. Fix the base, using the relative screws [B] of fig. 20-3 ensuring that the hole on the base [C] of fig. 20-3 is aligned with the cable outlet. 2 self-tapping screws are also supplied for fixture on surfaces with a different density.
06. Connect the electrical cable in the relative terminals of both TX and RX (fig. 20-4). From an electrical point of view, TX and RX must be connected in parallel (fig. 20-5) and to the blue terminal of the control board. *No polarity needs to be observed.*
07. Fix the covering shell [D] of fig. 20-6 with the two screws [E] of fig. 20-6 using a Phillips screwdriver. Lastly, insert the external cover [F] in fig. 20-6 pressing it slightly to secure in place.

6.2 - INSTALLING THE FL100 FLASHING LIGHT FL100 (fig. 21)

Select the position of the flashing light so that it is in the vicinity of the gate in a visible location; it can be fixed on either a horizontal or vertical surface; fig. 21 shows the two options:

01. Remove the cover, unscrewing the screw if present.
02. Separate the base, unscrewing the screws present to route the electric cables.
03. Trace the drilling holes using the base as a reference and ensuring that the hole on the base is aligned with the cable outlet. vertical fixture (A) or horizontal fixture.
04. Use a percussion drill to drill the wall, with a 6 mm tip, and insert 6 mm plugs.
05. Fix the base, using the relative screws.
06. Connect the electric cables in the relative FLASH and "aerial" terminals as shown in the figure: To facilitate operations, remove terminals, make connections, then refit the terminals.
No polarity needs to be observed on the FLASH terminal, while in the case of the shielded cable connection of the aerial, the sheath must be connected.
07. Insert the lamp holder in the base, taking care to press it down so that it locks into place;
08. Secure the body of the flashing light to the fixing support and turn it left until it clicks into place, then secure by means of the screw.

6.3 - ELECTRICAL CONNECTION TO CONTROL UNIT

01. Remove the lateral cover of the gearmotor: remove the screw and pull the cover upwards (fig. 22);
02. Depending on the position of the gearmotor (right or left), set the electric jumper for the direction of the opening manoeuvre (Open), see fig. 23;
03. Remove the rubber membrane of the hole made for insertion of the electric cables. Insert the cables required for connection of the various devices (fig. 24). Leave cable lengths of at least 40-50 cm.
04. From the rubber membrane, remove a sufficient part of the internal mesh for insertion of the cables. Then fit the membrane into its seat (fig. 25).
05. At this point, make the electrical connections of the various devices to the control unit terminals (see fig. 26 and following paragraphs).
 - The terminals have the same colour as the terminals on the corresponding devices; for example the grey terminal (OPEN) of the KS100 key-operated selector switch must be connected to the grey terminal (OPEN) of the control unit;
 - No polarity is needed for virtually any of the connections; only in the case of the shielded cable of the aerial, the central core and sheath must be connected as shown in detail [A] of fig. 26.*Notes: - To facilitate connections, terminals can be removed as shown in fig. 27 - [A]; after making the connections, refit the terminals in their seats. - At the end of connections, use cable ties to secure the electric cables to the relative fixtures (fig. 27 - [B]).*
06. Close the lateral cover of the gearmotor as shown in fig. 28.

20

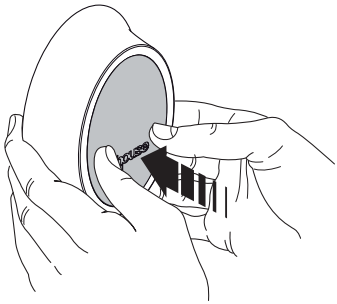

1 2

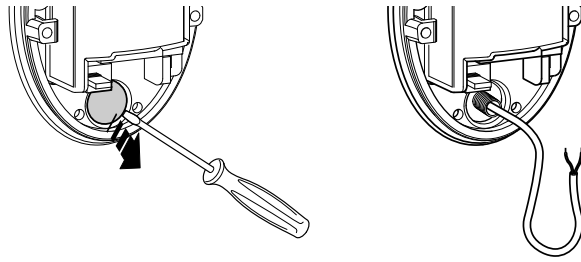

3

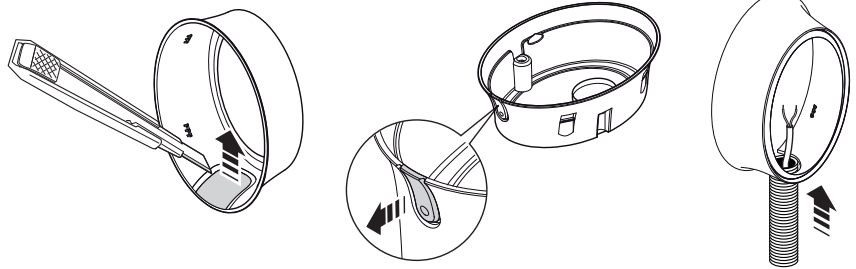
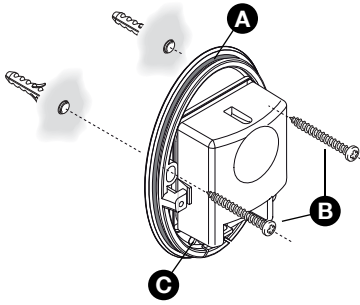

4

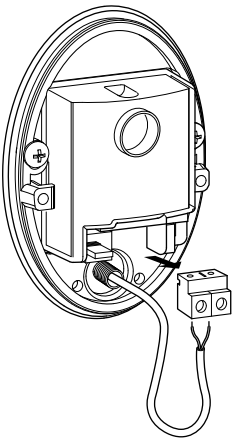

5

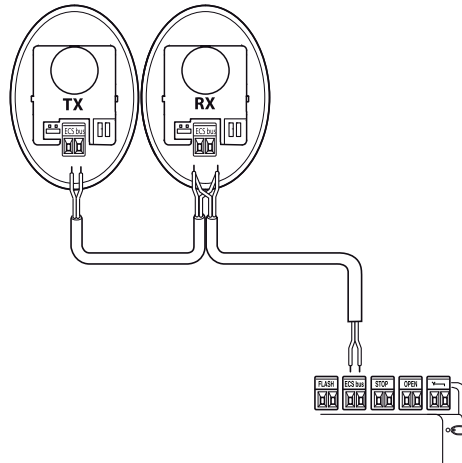

6

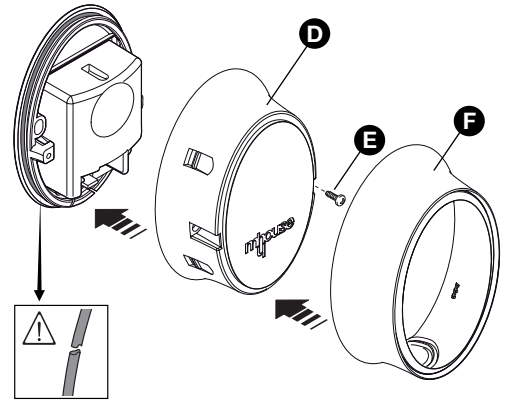

21

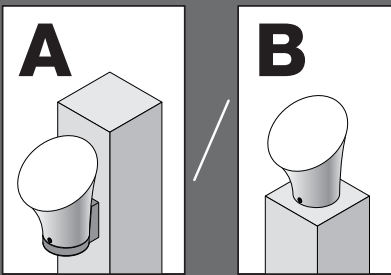

1

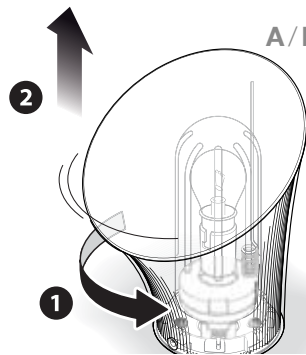

2

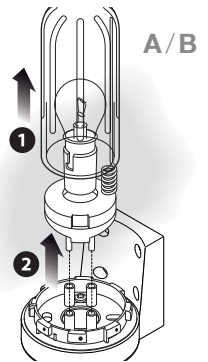

3

A/B

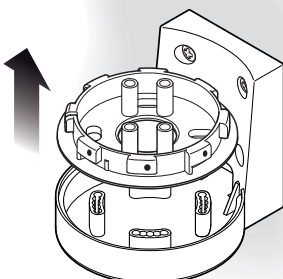

4

B

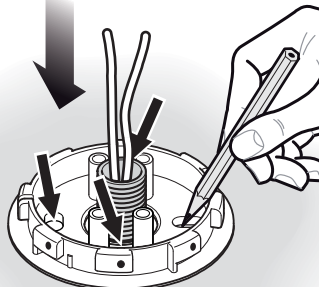

x4

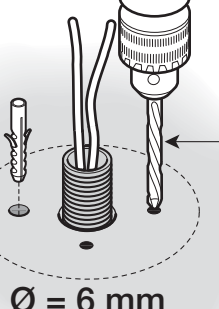

Ø = 6 mm

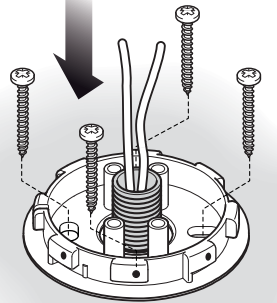

21

4

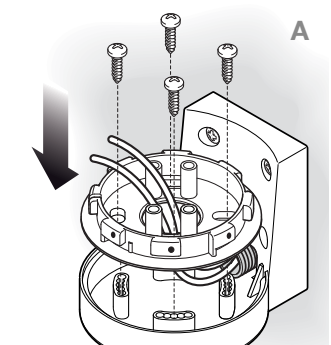
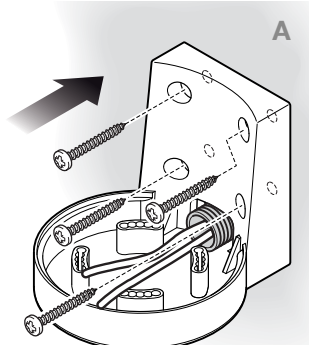
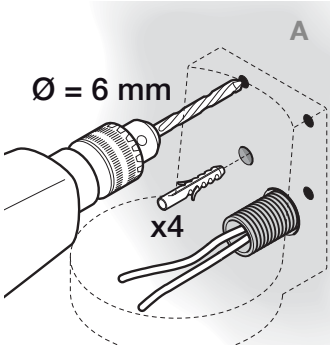
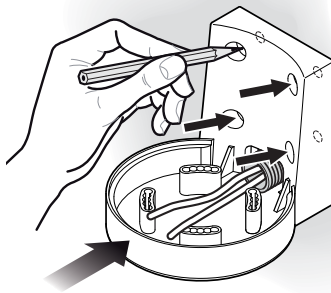

5

A/B

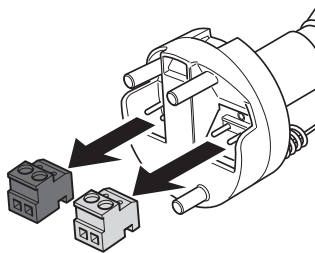

6

A/B

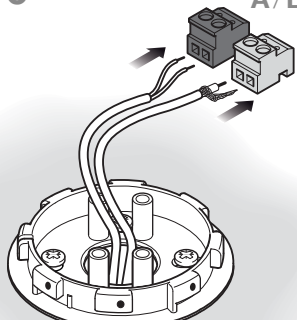

7

A/B

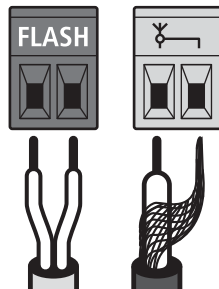

8

A/B

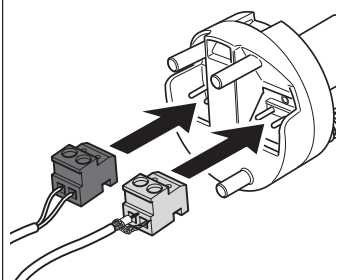

9

A/B

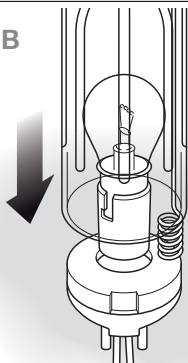

10

A/B

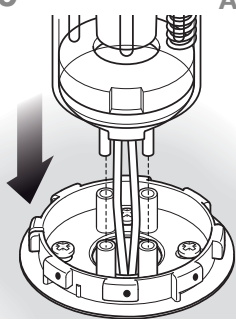

11

A/B

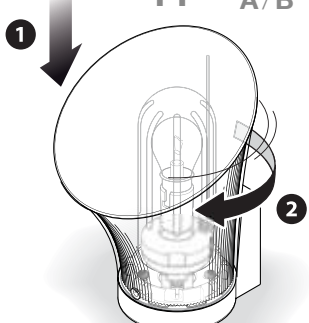

12

A/B

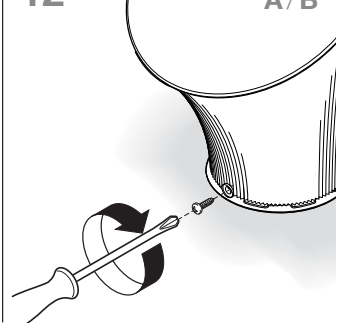

22

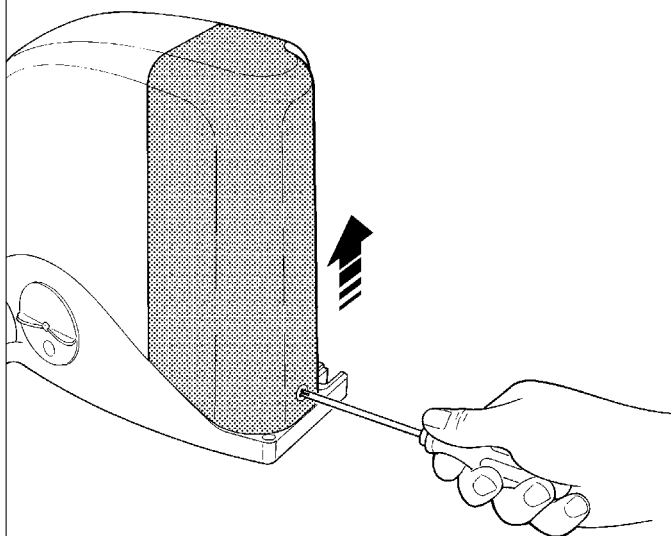

23

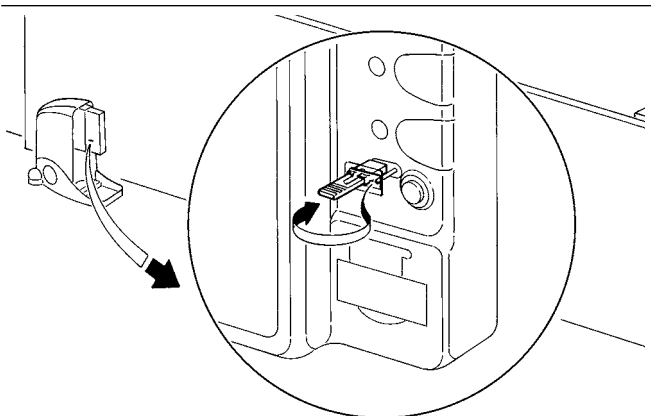
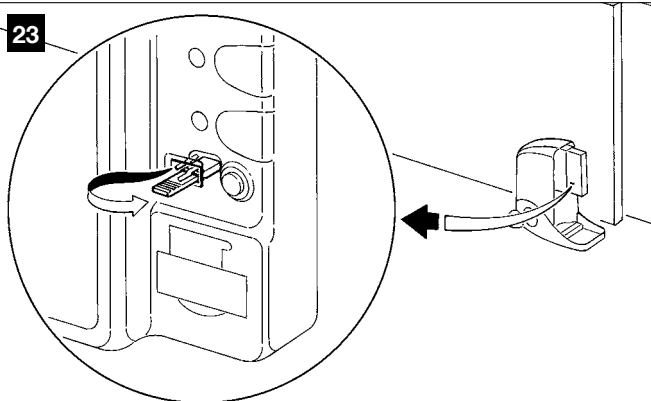

24

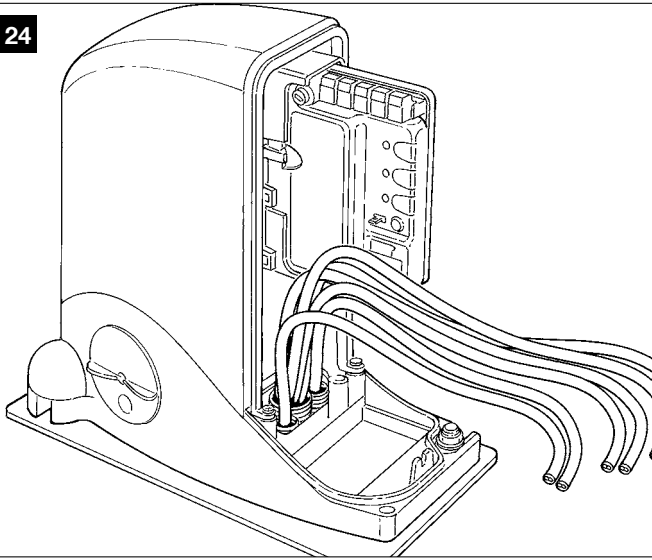

25

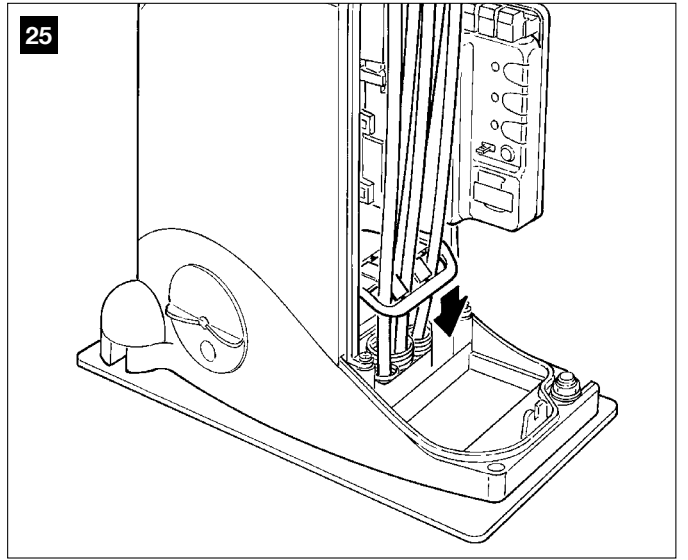

26

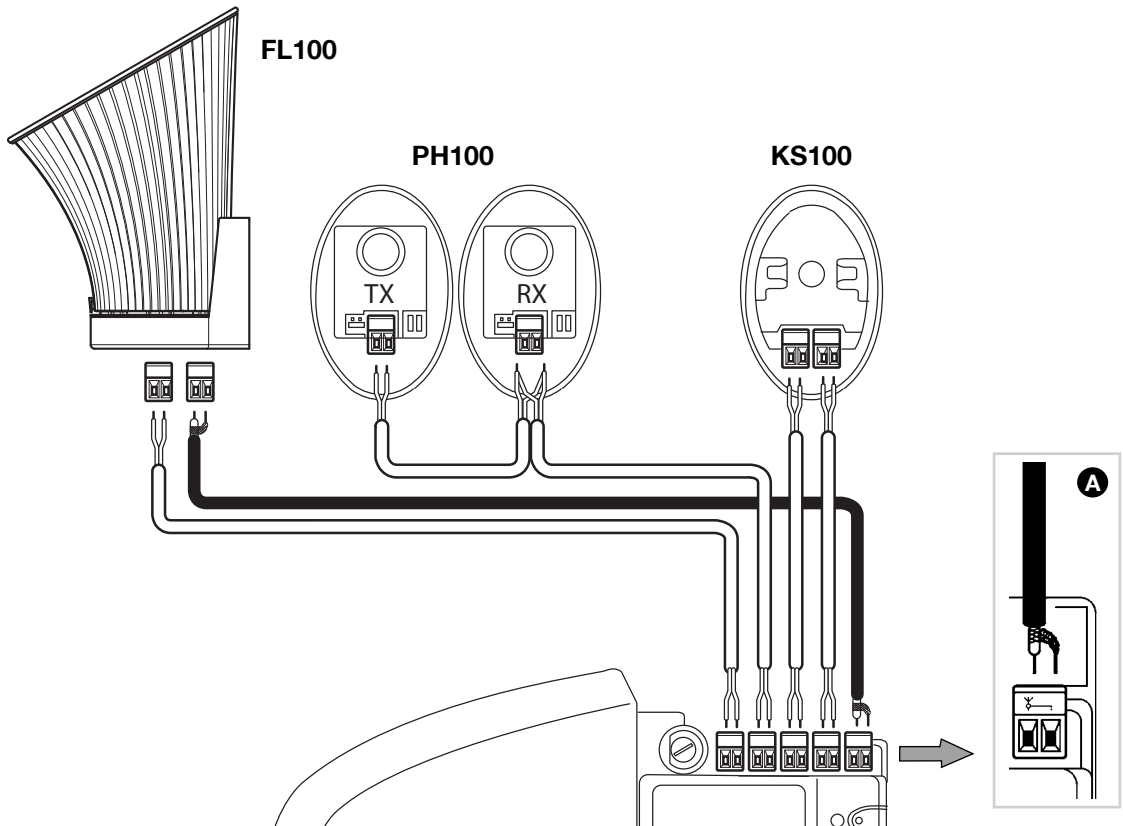

27

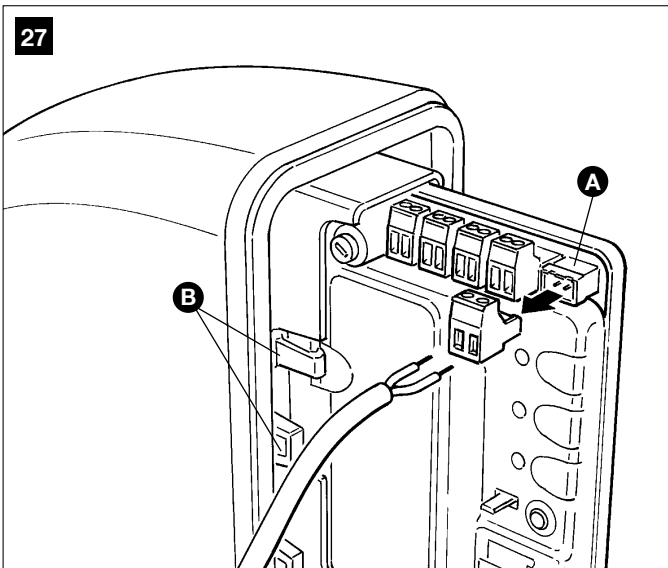

28

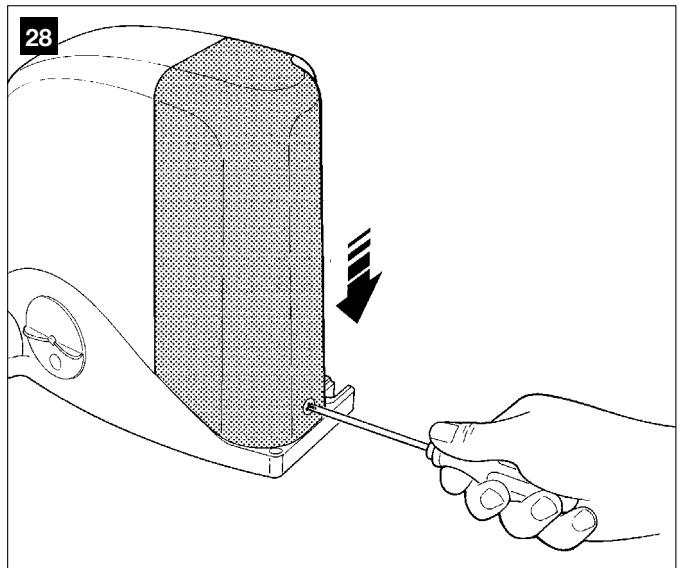



— STEP 7 —

7.1 - POWER SUPPLY CONNECTION

WARNINGS

– The power cable is in PVC and is designed for installation indoors. If installed outdoors, the entire cable must be covered with a protection ducting. Otherwise the cable can be replaced with a H07RN-F version.

– Final connection of the automation to the electrical mains or replacement of the cable supplied must be made exclusively by a qualified and skilled electrician, in observance of the current safety standards and the following instructions.

• For automation operation tests and programming, use the cable supplied, inserting the plug in an electrical socket. If the socket is far from the automation, an extension may be used in this phase.

• For the automation testing and commissioning phase the control unit must be permanently connected to the power mains, replacing the cable supplied with one of adequate length. To connect the cable to the gearmotor control unit, proceed as follows:

WARNING:

The power line must be fitted with a disconnect device that ensures complete shut-off of power to the automation. The disconnect device must have contacts with a sufficient gap to ensure complete disconnection, in compliance with the overvoltage category III, according to the installation instructions. If necessary, this device guarantees quick and safe disconnection from the mains power and therefore must be positioned in sight of the automation. If located in a concealed position, it must be equipped with a system that prevents inadvertent or unauthorised reconnection of power, to avoid potential hazards. The disconnect device is not supplied with the product.

01. Ensure that the gearmotor plug is not inserted in the mains socket;
02. Disconnect the electric cable on the gearmotor from the power terminal;
03. Loosen the collar [A] (fig. 29) present below the terminal and extract the electric cable. Replace it with the permanent electric power cable;
04. Connect the electric cable to the gearmotor power terminal (fig. 29);
05. Tighten down the collar [A] to secure the electric cable.

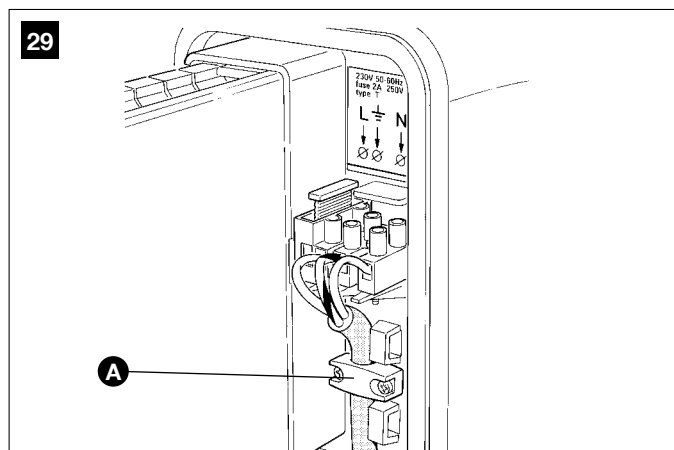

7.2 - INITIAL CHECKS

After powering up the control unit, perform the following checks:

01. Ensure that the led "ECSBus" [A] (fig. 30) flashes regularly with the frequency of 1 flash per second.
02. Ensure that the LED "SAFE" [B] (fig. 30) on the photocells is flashing (both on TX and RX); the type of flash is not important, as this depends on other factors; it is important that it is not off or permanently lit.
03. Ensure that the night-time light on the KS100 key-operated selector switch is on.
04. If these events do not occur, disconnect the control unit from the power supply and check the cable connections again with care. For other useful information, refer also to chapters 10.5 "Troubleshooting" and 10.6 "Diagnostics and signals".

7.3 - RECOGNITION OF THE CONNECTED DEVICES

On completion of initial checks, the control unit must be able to recognise the devices connected on the terminals "ECSBus" and "STOP".

01. On the control unit, press and hold P2 [A] (fig. 31) for at least 3 seconds, then release.
02. Wait a few seconds for the control unit to complete the device learning phase.
03. At the end of the learning phase the STOP led [B] (fig. 31) must remain lit, while the led P2 [C] (fig. 31) should turn off. If the LED P2 flashes it means there is an error; see paragraph 10.5 "Troubleshooting".

The phase for learning connected devices can be repeated at any time also after installation (for example if a photocell is added); simply repeat the procedure from point 01.

7.4 - CHECKING GATE LEAF MOVEMENT

After learning devices, the control unit must recognise the length of the gate. In this phase the length of the gate is measured from the closing limit switch to the opening limit switch. This measurement is required to calculate the points of deceleration and partial opening.

01. Release the gearmotor (see paragraph 11.3 – User's guide) and move the gate to mid-travel so that it is free to move in both the opening and closing directions; then lock the gearmotor.
02. On the control unit, press and release the key OPEN [A] (fig. 32); wait for the control unit to perform leaf opening until the opening limit switch is reached.
If the manoeuvre is not opening, press the OPEN key again to stop the manoeuvre and invert the position of the jumper, (see fig. 23) and then repeat point 02.
03. On the control unit, press and release the key OPEN [A] (fig. 32);
04. Perform a number of opening and closing manoeuvres, ensuring that the gate stops (reaching the limit switch) at least 2-3 centimetres before the mechanical stops.

7.5 - CHECKING THE RADIO TRANSMITTERS

To check transmitters, simply press one of its 4 keys, ensure that the LED flashes and that the automation performs the associated command. The command associated with each key depends on the mode in which they were memorised (see paragraph 10.4 "Memorising radio transmitters"). The transmitters supplied are already memorised and the keys, when pressed, send the following commands (fig. 33):

Key T1 =	"OPEN" command
Key T2 =	"Pedestrian opening" command
Key T3 =	"Only open" command
Key T4 =	"Only close" command

7.6 - SETTINGS

7.6.1 - Selecting the leaf speed

Leaf opening and closing can be at two speeds: "low" or "high". To change from one speed to another, briefly press key P2 [B] (fig. 34); the corresponding led P2 [A] (fig. 34) will turn on or off; when the led is off, the speed setting is "low", when the led is on the speed setting is "high".

7.6.2 - Selecting the operating cycle

Gate opening and closing can be performed in two different operating modes:

- Single cycle (semi-automatic): with one command, the gate opens and remains open until the next command which activates closing.
- Complete cycle (automatic closure): with one command, the gate opens and closes again automatically after a short interval (for the time interval, see paragraph 10.1 "Parameter settings via radio transmitter").

To change from one mode to another, briefly press key P3 [B] (fig. 35); the corresponding led [A] (fig. 35) will turn on or off; when the led is off, the cycle is "single", when the led is on the cycle is "complete".

30

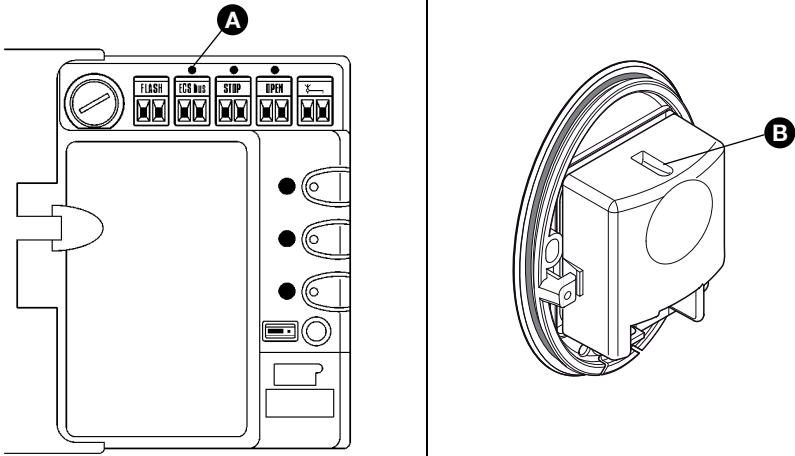

31

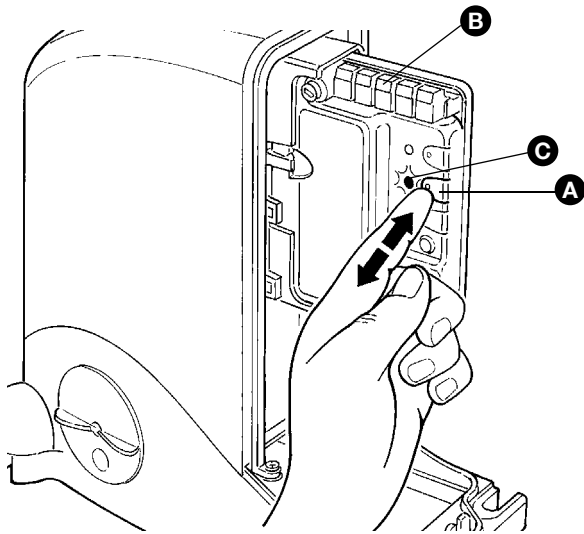

32

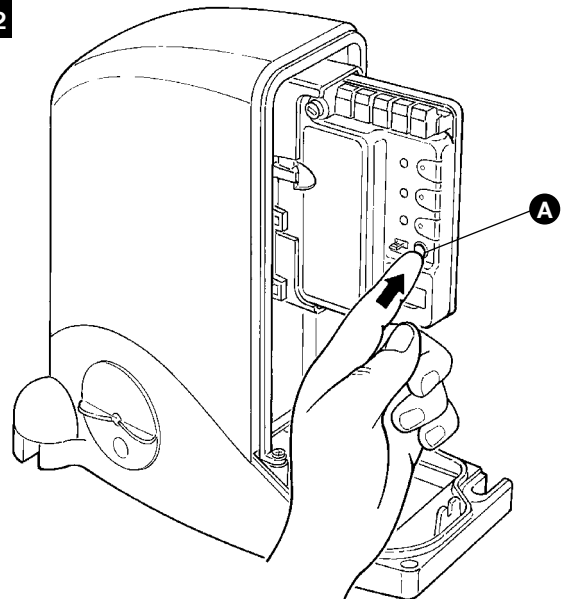

33

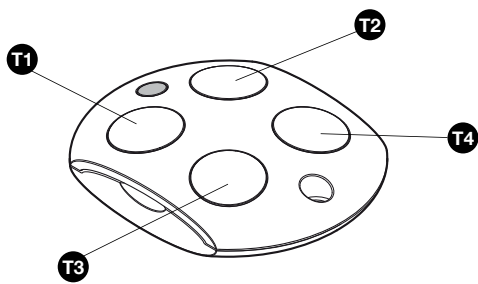

34

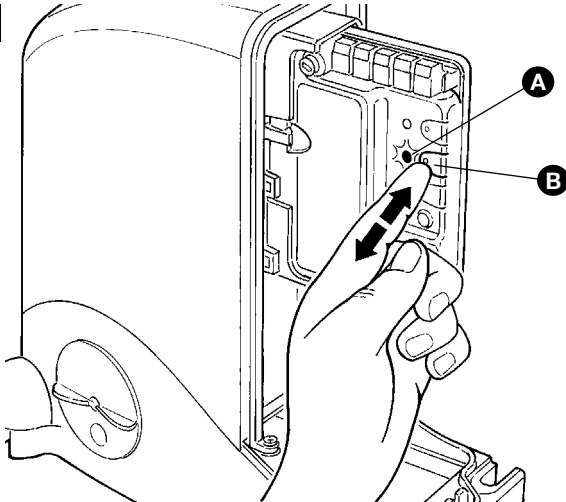

35

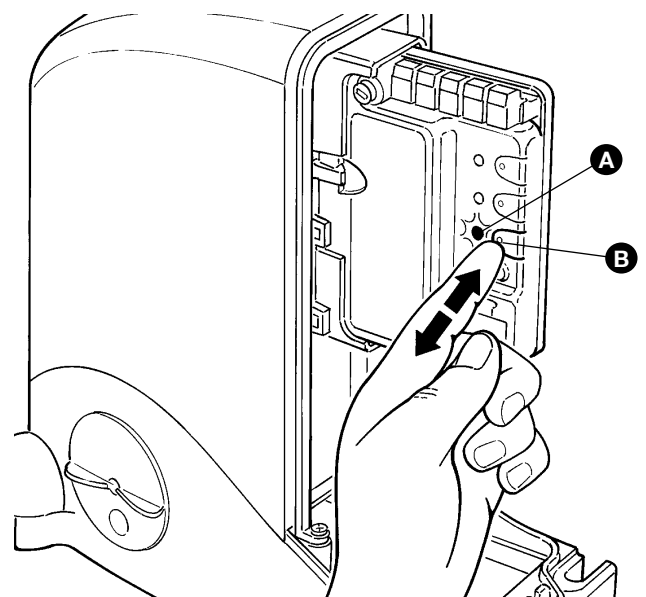



TESTING AND COMMISSIONING

— STEP 8 —

These are the most important phases when setting up an automation, in order to guarantee maximum safety. Testing can also be used as a periodic check of devices in the automation.

Testing of the entire system must be performed by skilled and qualified personnel, who are responsible for the tests required to verify the solutions adopted according to the risks present, and for ensuring observance of all legal provisions, standards and regulations, with particular reference to all requirements of the standard EN 12445 which establishes the test methods for testing automations for power-operated gates.

8.1 - TESTING

- 01. Ensure that all instructions and warnings in STEP 1 have been strictly observed.**
- 02.** Using the selector or radio transmitter, test gate opening and closing and ensure that leaf movement corresponds to the envisaged commands. Test several times to assess smooth operation of the gate and check for any defects in assembly or adjustment and any possible points of friction.
- 03.** Check operation of all system safety devices one at a time (photo-cells, sensitive edges, etc.). In particular, each time a device trips, the "ECSBus" led on the control unit emits a longer flash to confirm control unit recognition of the event.
- 04.** To test photocells and in particular that there is no interference with other devices, pass a cylinder (**Fig. 36**) (diameter 5 cm, length 30 cm) through the optic axis, first close to the TX and then the RX and then mid-way between the two. Ensure that in all cases the device engages, changing from the active status to alarm status and vice versa; then ensure that the action envisaged is performed on the control unit: during closure inverts movement.
- 05.** Measure the force as specified in the standard EN 12445. If the motor force control is used as an auxiliary function for reduction of impact force, test and identify the setting that obtains the best results.

8.2 - COMMISSIONING

Commissioning can only be performed after positive results of all test phases. Partial or "makeshift" commissioning is strictly prohibited.

- 01.** Produce the technical documentation of the automation, which must include at least the following documents: overall layout drawing (e.g. **fig. 3**), electrical wiring diagram (e.g. **fig. 26**), risk assessment and solutions adopted, manufacturer's declaration of conformity for all

devices used (use appendix 1).

- 02.** Affix a dataplate on the door, specifying at least the following data: type of automation, name and address of manufacturer (responsible for commissioning), serial number, year of construction and CE mark.
- 03.** Permanently attach to the gate the label supplied in the pack, regarding the procedure for manual locking/release of the gearmotor.
- 04.** Compile and provide the automation owner with the declaration of conformity (use appendix 2).
- 05.** Prepare and provide the automation owner with the User's guide; for this purpose appendix "User's guide" may be used as an example (chapter 11.3).
- 06.** Prepare and provide the owner with the form "Maintenance schedule", containing all maintenance instructions for all devices in the automation.
- 07.** Before commissioning the automation, ensure that the owner is adequately informed of all associated risks and hazards.

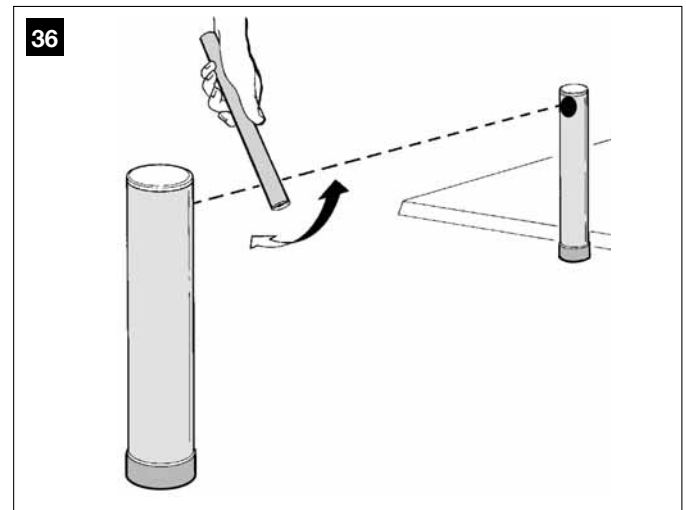

MAINTENANCE

— STEP 9 —

Maintenance must be performed in strict observance of the safety provisions in this manual and according to current legislation and standards.

The automation devices do not require special maintenance. However a check should be performed at least every six months to ensure complete

efficiency of all devices.

For this purpose, the tests and checks envisaged in paragraph 8.1 "Testing" should all be performed, as well as all procedure in the paragraph "Maintenance operations permitted for the user".

If other devices are present, follow the instructions in the relative maintenance schedule.



PRODUCT DISPOSAL

This product is an integral part of the automation and therefore must be disposed together with the latter.

As in installation, also at the end of product lifetime, the disassembly and scrapping operations must be performed by qualified personnel.

This product is made of various types of material, some of which can be recycled while others must be scrapped. Seek information on the recycling and disposal systems envisaged by the local regulations in your area for this product category.

Caution! – Some parts of the product may contain pollutant or hazardous substances which, if disposed of into the environment, may cause

serious damage to the environment or physical health.

As indicated by the symbol alongside, disposal of this product in domestic waste is strictly prohibited. Separate the waste into categories for disposal, according to the methods envisaged by current legislation in your area, or return the product to the retailer when purchasing a new version.

Caution! – Local legislation may envisage serious fines in the event of abusive disposal of this product.



— STEP 10 —

10.1 - ADVANCED SETTINGS

10.1.1 - Parameter settings via radio transmitter

The radio transmitter can be used to set a number of control unit operating parameters: there are four parameters and each of these may be assigned with four different values:

- 1) Pause time: the time for which the gate remains open (in the case of automatic closure).
- 2) Pedestrian opening: pedestrian gate opening mode.
- 3) Motor force: motor force over which the control unit recognises an obstacle and inverts movement.
- 4) "OPEN" Function: sequence of movements associated with each "OPEN" command.

TABLE 6

Parameters	NO.	Value	Action: operation to be performed at point 3 of the settings phase
Pause Time	1	10 s	Press T1 once
	2	20 s (*)	Press T1 twice
	3	40 s	Press T1 three times
	4	60 s	Press T1 four times
Pedestrian opening	1	Gate opening at 0.7 m	Press T2 once
	2	Gate opening at 1 m (*)	Press T2 twice
	3	Gate opening mid-way	Press T2 three times
	4	Gate opening at 3/4	Press T2 four times
Motor force	1	Low	Press T3 once
	2	Medium low (*)	Press T3 twice
	3	Medium high	Press T3 three times
	4	High	Press T3 four times
"OPEN" function	1	"Open", "Stop", "Close", "Stop"	Press T4 once
	2	"Open", "Stop", "Close", "Open" (*)	Press T4 twice
	3	"Open", "Close", "Open", "Close"	Press T4 three times
	4	Opening only	Press T4 four times

(*) Factory setting

The parameter setting operation can be performed using any radio transmitter, provided that it is memorised in mode 1, in the same way as that supplied (see paragraph 10.4.1 "Memorisation mode 1"). If there is no transmitter memorised in mode 1 a single one may be memorised for this phase, after which it must be deleted immediately (see paragraph 10.4.4 "Deleting a radio transmitter").

CAUTION! – When making settings via a transmitter, the control unit must be allowed sufficient time to recognise the command via radio; in practice the keys must always be pressed and released slowly, pressing for at least one second, releasing for one second and so on.

01. Press T1 and T2 simultaneously (fig. 37) on the radio transmitter for at least 5 s.
02. Release the two keys.
03. Within three seconds, complete the action as specified in Table 6 according to the parameter to be modified.

Example: to set the pause time at 40 s.

01. Press and hold the keys T1 and T2 simultaneously for at least 5 seconds
02. Release T1 and T2
03. Press T1 three times

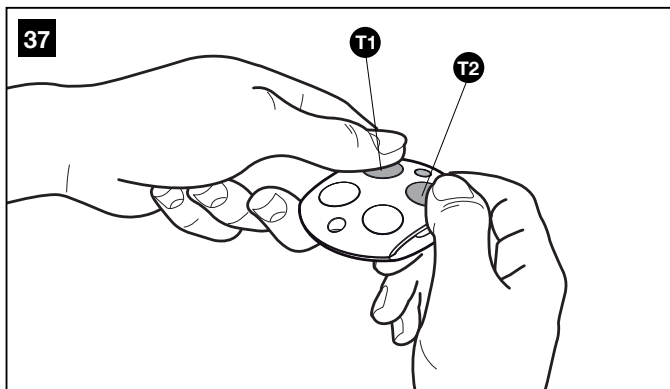

All parameters can be adjusted as required without any contraindications, only the "Motor force" setting may require special attention:

- Do not use force values to compensate for anomalous points of friction on the gate. Excessive force settings may impair safety system operation or cause damage to the gate.
- If the "Motor force control" is used in support of the system for impact

force reduction, after each adjustment the force measurement procedure must be performed, as envisaged by standard EN 12445.

- Weather conditions can influence gate movement; new adjustments may be required periodically.

10.1.2 - Checking settings via a radio transmitter

With a radio transmitter memorised in Mode 1 the user can check settings at any time for each parameter, as follows:

01. Press T1 and T2 simultaneously on the radio transmitter for at least 5 s.
02. Release the two keys.
03. Within three seconds, complete the action as specified in Table 7 according to the parameter to be modified.
04. Release the key when the flashing light starts to flash.
05. Count the number of flashes and, according to the number, check the corresponding value on Table 6.

Example: After pressing T1 and T2 for 5 s followed by T1, if the flashing light flashes three times, the pause time is set at 40 s

TABLE 7

Parameter	Action
Pause Time	Press and hold T1
Pass door	Press and hold T2
Motor force	Press and hold T3
"OPEN" function	Press and hold T4

10.2 - OPTIONAL ACCESSORIES

As well as the devices in SL1S-SL10S, there are a number of optional accessories which may be used to integrate the automation system.

- PR1:** 24 V buffer battery; in the event of a mains power failure, this guarantees at least 10 complete cycles.
 - PF:** 24 V solar power system; useful in cases in which there is no electrical mains power.
 - PT50:** Pair of columns (height 500 mm) with photocell
 - PT100:** Pair of columns (height 1000 mm) with two photocells
- For information on new accessories, consult the MHOUSE catalogue or visit the website www.mhouse.com.

10.2.1 - Installing the PR1 buffer battery (fig. 38)

CAUTION! - The electric connection of the battery to the control unit must only be made after completing all installation and programming phases, as the battery constitutes an emergency power supply.

To install and connect the buffer battery PR1 to the control unit, refer to **fig. 38** and the PR1 instruction manual.

When the automation is powered by the buffer battery, 60 seconds after a manoeuvre is completed, the control unit automatically switches off the output "ECSbus" (and all connected devices), output Flash and all leds, with the exception of the ECSbus led, which flashes at slower intervals; this indicates the "Standby" function. When the control unit receives a command, it restores normal operation (with a short delay). This function is used to reduce consumption; an important factor when the unit is powered by battery.

10.2.2 - Installing the PF solar power supply system (fig. 39)

CAUTION! - When the automation is powered exclusively by the solar power system "PF", **IT MUST NEVER BE POWERED at the same time by the mains.**

To connect the PF solar power system to the control unit, refer to **fig. 39** and the PF instruction manual.

When the automation is powered by the solar panel, 60 seconds after a manoeuvre is completed, the control unit automatically switches off the output "ECSbus" (and all connected devices), output Flash and all leds, with the exception of the ECSbus led, which flashes at slower intervals; this indicates the "Standby" function. When the control unit receives a command, it restores normal operation (with a short delay). This function is used to reduce consumption; an important factor when the unit is powered by photovoltaic panels.

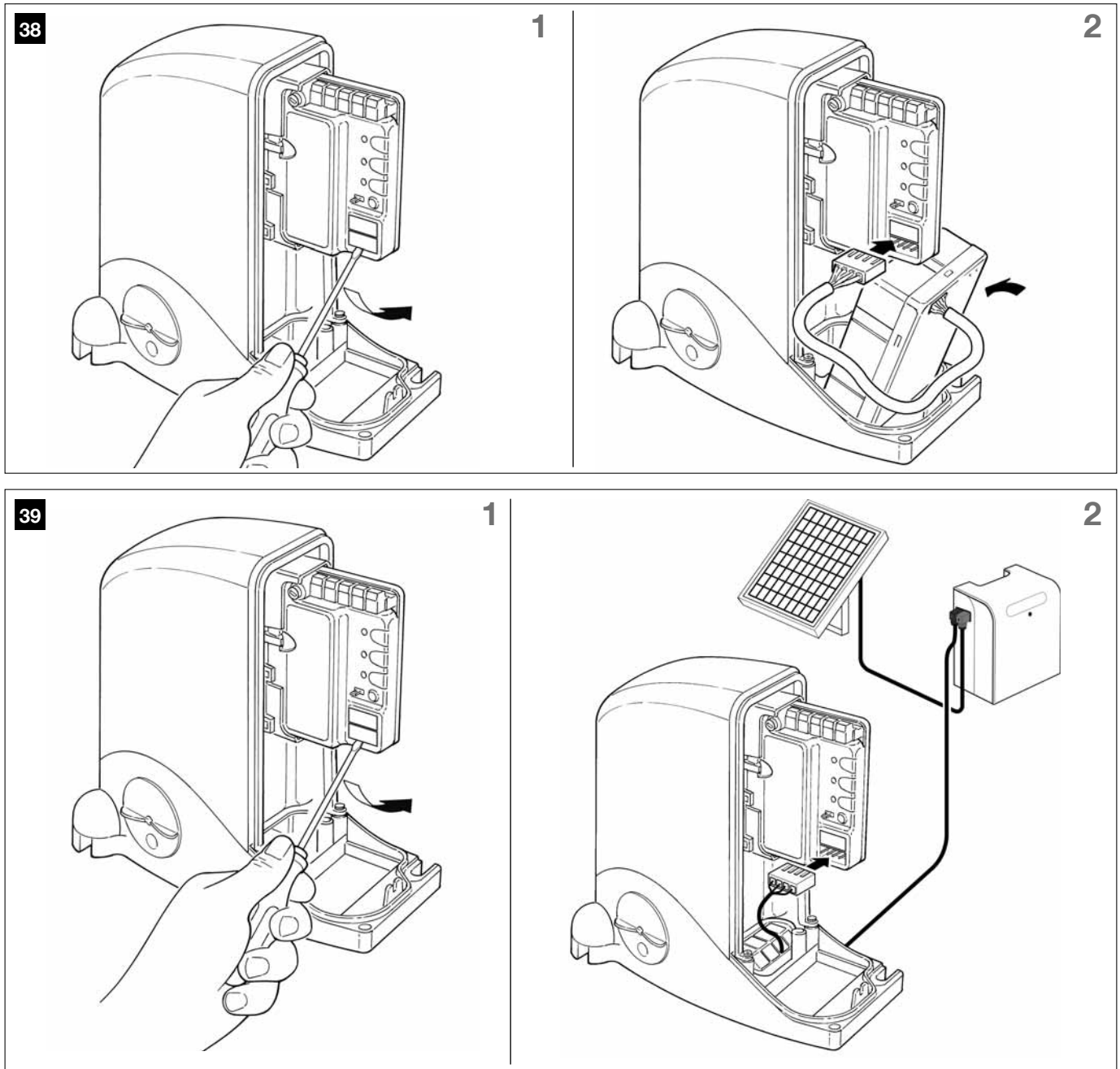

10.2.3 - Maximum possible number of cycles per day

This product is specifically designed to operate also with the PF solar power supply system. Special technical provisions have been envisaged to minimise energy consumption when the automation is stationary, by turning off all devices not essential to operation (for example photocells and the key-operated selector switch). In this way all energy available and

stored in the battery is used to move the gate.

Caution! - When the automation is powered by the solar power system "PF", **IT MUST NEVER BE POWERED at the same time by the mains.**

Application limits: maximum possible number of cycles per day within a set period of the year.

The PF solar power system enables complete power autonomy of the automation, until the energy produced by the photovoltaic panel and stored in the battery remains above the amount consumed during gate manoeuvres. A simple calculation enables an estimate of the maximum number of cycles per day performed by the automation in a certain period of the year, provided that a positive energy balance is maintained.

The first step in **calculating the energy available**, is dealt with in the PF instruction manual; the second step in **calculating the energy consumed** and therefore the maximum number of cycles per day, is dealt with in this chapter.

Calculating the energy available

To calculate the energy available (refer also to the PF instruction manual) proceed as follows:

01. On the terrestrial map supplied in the PF kit instruction manual, locate the point of system installation; then read the value E_a and the degrees of **latitude** of this location (E.g. $E_a = 14$ and degrees = $45^\circ N$)
02. On the graphs (North or South) supplied in the PF kit instruction manual, locate the curve for the location's **latitude** (e.g. $45^\circ N$)
03. Choose the **period of the year** on which to base the calculation, or select the **lowest point** of the curve to calculate the **worst period of the year**; then read the corresponding value A_m (e.g. December, January: $A_m = 200$)
04. Calculate the value of energy available **Ed** (produced by the panel) multiplying $E_a \times A_m = E_d$ (e.g. $E_a = 14$; $A_m = 200$ therefore $E_d = 2800$)

Calculating the energy consumed

To calculate the energy consumed by the automation, proceed as follows:

05. On the table below, select the box corresponding to the intersection between the line with the **weight** and the column with the **opening angle** of the gate leaf. The box contains the value of the **severity index** (K) for each manoeuvre (e.g. SL1S with a leaf of 250 Kg and opening of 3.5 m; $K = 200$).

SL1S Leaf weight	Leaf length		
	<3 m	3÷4 m	4÷5 m
< 150 Kg	84	108	132
150-250 Kg	120	144	184
250-350 Kg	160	200	240
350-400 Kg	204	252	300

SL10S Leaf weight	Leaf length				
	<3 m	3÷4 m	4÷5 m	5÷6 m	6÷7 m
< 150 Kg	108	144	180	210	240
150-250 Kg	152	200	248	280	328
250-350 kg	200	260	320	360	420
350-450 Kg	252	324	396	444	516
450-550 Kg	308	392	476	532	616

06. On the **table A** below, select the box corresponding to the intersection between the line with the E_d value and the column with the K value. The box contains the maximum possible number of cycles per day (e.g. $E_d = 2800$ and $K = 200$; cycles per day ≈ 14)

If the number obtained is too low for the envisaged use or is located in the "area not recommended for use", the use of 2 or more photovoltaic panels may be considered, or the use of a photovoltaic panel with a higher power. Contact the Mhouse technical assistance service for further information.

The method described enables the calculation of the maximum possible number of cycles **per day** that can be completed by the automation while running on solar power. The calculated value is considered an average value and the same for all days of the week. Considering the presence of the battery, which acts as an energy "storage depot", and the fact that the battery enables automation autonomy also for long periods of bad weather (when the photovoltaic panel produces very little energy) it may be possible to exceed the calculated maximum possible number of cycles per day, provided that the average of 10-15 days remains within the envisaged limits.

Table B below specifies the maximum possible number of cycles, according to the manoeuvre's **severity index** (K), using **exclusively the energy stored** by the battery. It is considered that initially the battery is completely charged (e.g. after a prolonged period of good weather or recharging via the optional PCB power supply unit) and that the manoeuvres are performed within a period of 30 days.

When the battery runs out of the stored energy, the led starts to indicate the battery low signal by flashing briefly every 5 seconds, accompanied by a "beep".

TABLE A - Maximum possible number of cycles per day

Ed	K≤100	K=150	K=200	K=250	K=300	K=350	K=400	K=450	K=500	K=550	K≥600
9500	93	62	47	37	31	27	23	21	19	17	16
9000	88	59	44	35	29	25	22	20	18	16	15
8500	83	55	42	33	28	24	21	18	17	15	14
8000	78	52	39	31	26	22	20	17	16	14	13
7500	73	49	37	29	24	21	18	16	15	13	12
7000	68	45	34	27	23	19	17	15	14	12	11
6500	63	42	32	25	21	18	16	14	13	11	11
6000	58	39	29	23	19	17	15	13	12	11	10
5500	53	35	27	21	18	15	13	12	11	10	9
5000	48	32	24	19	16	14	12	11	10	9	8
4500	43	29	22	17	14	12	11	10	9	8	7
4000	38	25	19	15	13	11	10	8	8	7	6
3500	33	22	17	13	11	9	8	7	7	6	6
3000	28	19	14	11	9	8	7	6	6	5	
2500	23	15	12	9	8	7	6	5			
2000	18	12	9	7	6	5					
1500	13	9	7	5							
1000	8	5									

Area of use not recommended

TABLE B - Maximum number of cycles using exclusively battery power

K≤100	K=150	K=200	K=250	K=300	K=350	K=400	K=450	K=500	K=550	K≥600
586	391	293	234	195	167	147	130	117	107	98

10.3 - ADDING OR REMOVING DEVICES

An automation using SL1S-SL10S enables devices to be added or removed at any time.

Caution! - Do not add devices before ensuring that they are fully compatible with SL1S-SL10S; for further details, contact the MHOUSE technical assistance.

10.3.1 - ECSBus

ECSBus is a system that enables connections of ECSBus devices using just two wires, which convey both electrical power and communication signals. All devices are connected in parallel on the same 2 wires of the ECSBus; each device is recognised individually as it is assigned a unique address during installation.

Photocells and other devices using this system can be connected to ECSBus, such as safety devices, control buttons, indicator lights etc. For information on ECSBus devices, refer to the MHOUSE catalogue or visit the website www.mhouse.com.

A special learning phase enables the control unit to recognise all connected devices individually, and enables precise diagnostics procedures. For this reason, each time a device connected to ECSBus is added or removed, the learning phase must be performed on the control unit; see paragraph 10.3.3 "Learning other devices".

10.3.2 - STOP Input

STOP is the input that causes immediate shutdown of the movement (followed by a brief inversion of the manoeuvre). This input can be connected to devices with contact types Normally Open (NO, as in the case of the KS100 selector switch), Normally Closed (NC) or devices with a constant resistance of 8.2 K Ω , such as sensitive edges.

When set accordingly, more than one device can be connected to the STOP input, also different from one another; see **Table 8**.

TABLE 8				
2 nd device type:	1 st device type:			
	NA	NC	8,2 K Ω	
NA	In parallel (<i>note 2</i>)	(<i>note 1</i>)	In parallel	
NC	(<i>note 1</i>)	In series (<i>nota 3</i>)	In series	
8,2K Ω	In parallel	In series	(<i>nota 4</i>)	

Note 1. The NO and NC combination can be obtained by placing the two contacts in parallel, and placing an 8.2k Ω resistance in series with the NC contact (it is, therefore, possible to combine 3 devices: NA, NC and 8,2k Ω).

Note 2. Any number of NO devices can be connected to each other in parallel.

Note 3. Any number of NC devices can be connected to each other in series.

Note 4. Only two devices with an 8.2 k Ω constant resistance output can be connected in parallel; multiple devices must be connected "in cascade" with a single 8.2 k Ω termination resistance.

Caution! – If the STOP input is used to connect devices with safety functions, only the devices with 8.2 k Ω constant resistance output will guarantee the fail-safe category .

As with the ECSBus, the control unit recognises the type of device connected to the STOP input during the learning phase; subsequently the control unit gives a STOP command when it detects a variation with respect to the learned state.

10.3.3 - Recognition of other devices

The learning operation of the devices connected to the ECSBus and STOP input is usually carried out during the installation phase; if devices are added or removed the learning operation can be carried out again as follows:

01. Press and hold key P2 on the control unit for at least three seconds **[B] (fig. 40)**, then release the key.
02. Wait a few seconds to allow the control unit to finish learning the devices.
03. At the end of the learning the LED P2 **[A] (fig. 40)** should switch off. If the LED P2 flashes it means there is an error; see paragraph 10.5 "Troubleshooting".
04. After having added or removed a device the automation test must be carried out again as specified in paragraph 8.1 "Testing".

10.3.4 - Adding optional photocells

Additional photocells to those supplied with the SL1S-SL10S can be installed at any time. In systems for the automation of sliding gates they must be installed as shown in **fig. 41**.

In order for the control unit to correctly recognise the photocells they must be assigned with addresses using special electric jumpers. The address assignment operation must be carried out on both TX and RX (placing the electric jumpers in the same way) and it is important to check that there are not any other pairs of photocells with the same address. The photocell address assignment operation is necessary for them to be correctly recognised among the other devices of the ECSBus and to assign them their function.

01. Open the housing of the photocell.
02. Identify the position in which they are installed according to Figure 70 and place the jumper according to **Table 9**. Unused jumpers must be placed in the special compartment for future use (**fig. 42**).
03. Carry out the learning phase as described in paragraph 10.3.3 "Recognition of other devices".

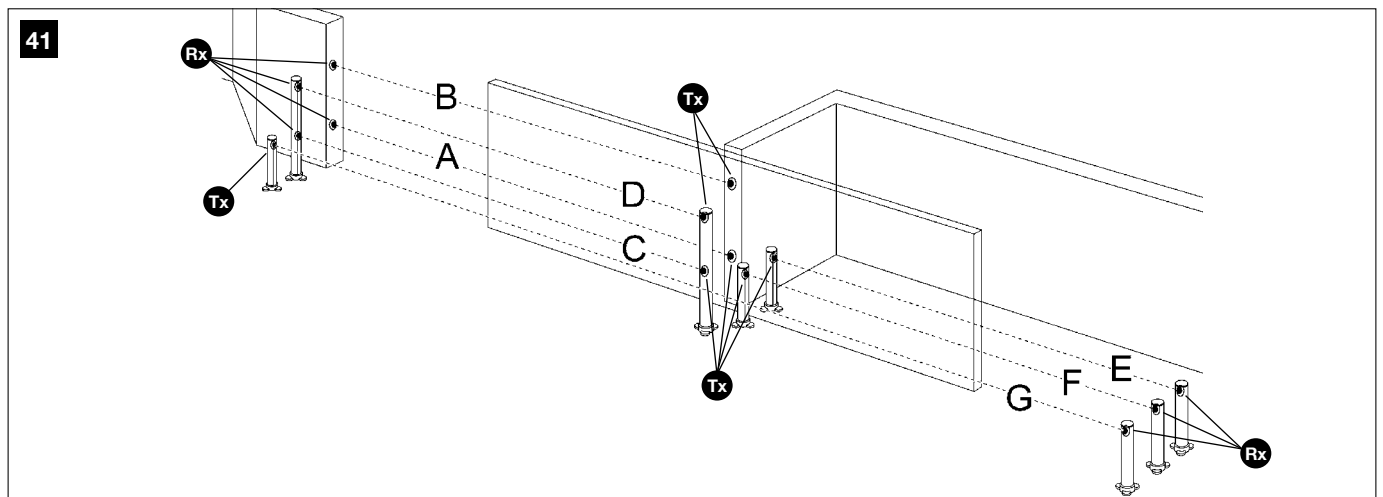
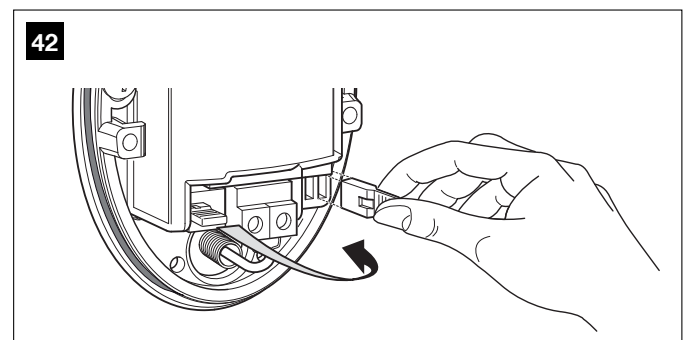
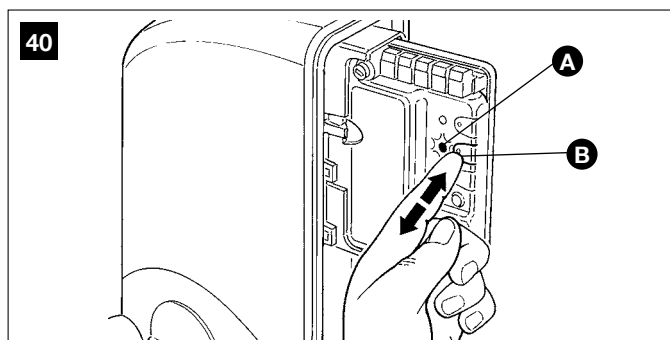

TABLE 9

Photocell		Jumpers			
A	External photocell h=50cm; triggered on closure		E	External photocell triggered on opening	
B	External photocell h=100 cm; triggered on closure		F	Internal photocell triggered on opening	
C	Internal photocell h=50 cm; triggered on closure		G	Single photocell that covers the entire automation and is triggered on closure and opening	
D	Internal photocell h=100 cm; triggered on closure		<p>Note: normally there are no restrictions to the position of the two elements that make up the photocell (TX-RX). Only if photocell G is used with photocell B it is necessary to follow the positions shown in fig. 41.</p>		

10.4 - MEMORIZING ALL RADIO TRANSMITTERS

The control unit contains a radio receiver for GTX4 transmitters; the transmitter included in the box is already memorised and ready to use. There are two ways of memorising a new transmitter:

• **Mode 1:** in this "mode" the radio transmitter is used as a whole, i.e. all the keys carry out a preset command (the transmitter supplied with the SL1S-SL10S is memorised using Mode 1). Obviously a radio transmitter in mode 1 can only control one single automation; that is:

Key T1	"OPEN" command
Key T2	"Pedestrian opening" command
Key T3	"Only open" command
Key T4	"Only close" command

• **Mode 2:** each key can be associated to one of the four commands available. If this mode is used appropriately 2 or more different automations can be controlled, for example:

Key T1	"Only open" command Automation N° 1
Key T2	"Only close" command Automation N° 1
Key T3	"OPEN" command Automation N° 2
Key T4	"OPEN" command Automation N° 3

Obviously each transmitter is treated separately and for one single control unit there can be some transmitters memorised in mode 1 and others in mode 2.

The overall maximum memory capacity is of 150 units; mode 1 memorisation occupies one unit per transmitter while mode 2 occupies one unit per key.

Caution! – As memorisation procedures have a time limit (10 s), it is important to read the instructions in the next paragraphs before starting.

10.4.1 - Memorisation mode 1

- Press key P1 [B] (**fig. 43**) for at least 3 s. When the LED P1 [A] (**fig. 43**) switches on release the key.
- Within 10 s press any one key on the transmitter for at least 3 s to memorise it. If the memorisation procedure is successful, the LED P1 will emit 3 flashes.
- If there are other transmitters to be memorised repeat step 2 within the next 10 s otherwise the memorisation phase will end automatically.

10.4.2 - Memorisation mode 2

With Mode 2 memorisation each key can be associated with any one of the four commands: "OPEN", "Partially open", "Only open" and "Only close".

In Mode 2 each key requires its own memorisation phase.

- If the transmitter to be memorised is already memorised (such as the transmitters supplied which are already memorised in mode 1) the transmitter must be deleted following the procedure described in: "10.4.4 - Deleting a radio transmitter".
- Press key P1 [B] (**fig. 43**) on the control unit the number of times equal to the required command, according to **Table B** (e.g. 3 times for the "Only open" command").
- Check that LED P1 [A] (**fig. 43**) flashes quickly for a number of times equal to the command selected.
- Within 10 s press the required key on the radio transmitter for at least 2 s to memorise it. If the memorisation procedure is successful, the LED P1 will emit 3 slow flashes.
- If there are other transmitters to be memorised for the same type of command, repeat step 03 within the next 10 s otherwise the memorisation phase will end automatically.

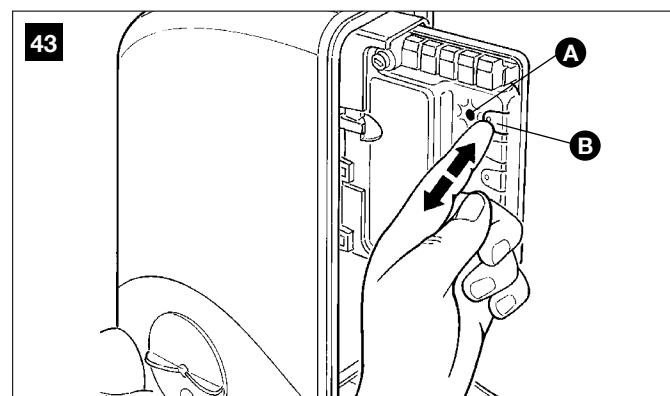

TABLE B

once	"Open" command
twice	"Pedestrian opening" command
three times	"Only open" command
Four times	"Only close" command
Five times	"Stop" command
Six times	"Apartment block" open command
Seven times	"High priority open" command
Eight times	"Pedestrian opening 2" command
Nine times	"Pedestrian opening 3" command
Ten times	"Open+ block automation" command
Eleven times	"Close + block automation" command
Twelve times	"Block automation" command
Thirteen times	"Unblock automation" command

10.4.3 - Remote memorisation

A new radio transmitter can be memorised on the control unit without having to use the unit itself. It is sufficient to have an "OLD" working and memorised radio transmitter. The "NEW" radio transmitter will "inherit" the characteristics of the OLD one; in other words if the old one is memorised in Mode 1 then the NEW one will also be memorised in Mode 1; in this case during the memorisation phase press any one key on the two transmitters. If the OLD radio transmitter is memorised in Mode 2 press the key with the required command on the OLD transmitter and press the key on the NEW transmitter with which you wish to associate the new command.

Take the two transmitters and position yourself within the action range of the automation and follow the following steps:

01. Press the key on the NEW radio transmitter for at least 5 s then release it.
02. Press the key on the OLD radio transmitter slowly 3 times.
03. Press the key on the NEW radio transmitter slowly once.

At this point the NEW radio transmitter will be recognised by the control unit and will take on the characteristics of the OLD one.

Repeat these steps for each new transmitter to be memorised.

10.4.4 - Deleting a radio transmitter

It is necessary to have a radio transmitter to delete it.

If the transmitter is memorised in Mode 1 one single deletion phase is sufficient and at point 3 any key can be pressed. If the transmitter is memorised in Mode 2 a deletion phase must be carried out for each key

01. Press and hold down key P1 on the control unit until the end of the procedure.
02. Wait for the LED P1 [A] (fig. 43) to switch on and within three seconds.
03. Press the key on the radio transmitter to be deleted for at least three seconds. If deletion is successful LED P1 will emit five quick flashes. If LED P1 emits one slow flash it means that the deletion has not been completed because the transmitter is not memorised.
04. To delete other transmitters keep key P1 pressed and repeat step 3 within 10 seconds otherwise the deletion procedure will end automatically.

10.4.5 - Deleting all radio transmitters

This procedure deletes all memorised transmitters.

01. Press and hold key P1 [B] (fig. 43) on the control unit.
02. Wait for LED P1 [A] (fig. 43) to switch on, then off and then flash 3 times.
03. Release key P1 precisely when the LED flashes the third time.
04. Wait about 4 s for deletion to be completed, during which the LED P1 will emit quick flashes.

If the procedure is successful after a few moments the LED P1 will emit 5 slow flashes.

10.5 - TROUBLESHOOTING

Table 10 gives possible indications on how to deal with malfunctions that may be met during installation or due to a fault.

10.6 - DIAGNOSTICS AND SIGNALS

Some devices directly provide particular signals to describe the state of operation or eventually a malfunction.

10.6.1 - Photocells

The photocells contain a LED "SAFE" [A] (fig. 45) that provides information at any moment on the state of operation; see Table 11.

TABLE 10 (fig. 44)

Symptoms	Probable cause and possible solution
The radio transmitter does not emit any signal (the LED [A] does not light up)	<ul style="list-style-type: none"> • Check whether the batteries are flat and if necessary replace them (page 36)
The manoeuvre does not start and the LED "ECSBbus" [B] does not flash	<ul style="list-style-type: none"> • Check that the power supply cable is correctly inserted in the mains socket • Check that the fuses [E] and [F] have not been activated; if this is the case check the cause of the fault and replace them with other fuses with the same characteristics
The manoeuvre does not start and the flashing light is off	<ul style="list-style-type: none"> • Check that the command is actually received. If the command reaches the OPEN input the relevant LED "OPEN" [D] should light up; if a radio transmitter is used the LED "ECSBus" should emit two long flashes
The manoeuvre does not start and the flashing light flashes	<ul style="list-style-type: none"> • Check that the STOP input is active, in other words that the LED "STOP" [C] is on. If this is not the case check the device connected to the STOP input • The photocell test carried out at the beginning of each manoeuvre is negative; check the photocells and refer to Table 11
The manoeuvre starts but is immediately followed by an inversion	<ul style="list-style-type: none"> • The force selected is too low to move the gate. Check whether there are any obstacles and if necessary select a higher force as described in paragraph "10.1.1 - Adjusting the parameters with the radio transmitter"
The manoeuvre is carried out but the flashing light is not working	<ul style="list-style-type: none"> • During the manoeuvre, ensure that there is voltage on the FLASH terminal of the flashing light (as this is intermittent, the voltage value is not significant: approx. 10-30 Vac); if voltage is present, the problem is due to the lamp, which should be replaced with an identical version

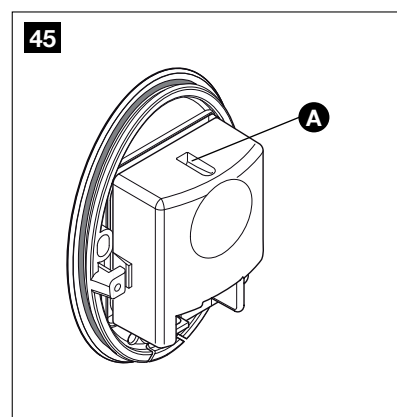
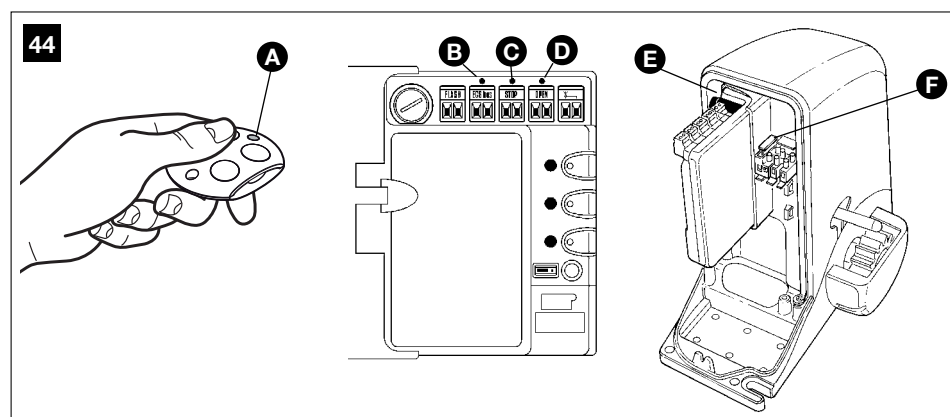

TABLE 11

LED "SAFE"	STATUS	ACTION
Off	The photocell is not powered or it is faulty	Check that the voltage on the photocell terminals is of about 8-12 Vdc; if the voltage is correct then the photocell is probably faulty
3 quick flashes and 1 second pause	Device not recognised by the control unit	Repeat the learning procedure on the control unit. Check that all the photocell pairs on ECSBus have different addresses (see Table 9)
1 very slow flash	The RX receives an excellent signal	Normal operation
1 slow flash	The RX receives a good signal	Normal operation
1 quick flash	The RX receives a poor signal	Normal operation but check TX-RX alignment and correct cleaning of photocell lenses
1 very quick flash	The RX receives a bad signal	At the limit of normal operation; check TX-RX alignment and correct cleaning of photocell lenses
Always lit	The RX does not receive any signal	Check for any obstruction between TX and RX. Check that the LED on the TX flashes slowly. Check TX-RX alignment

10.6.2 - Flashing light

During a manoeuvre the flashing light flashes every second; in case of anomalies the light flashes at more frequent intervals (half a second); the

flashes are repeated twice with an interval of one second; see **Table 12**.

TABLE 12

Quick flashes	Status	Action
1 flash 1 second pause 1 flash	ECSbus error	At the beginning of the manoeuvre the devices present do not correspond with those recognised; check and eventually carry out the learning procedure (10.3.3 "Recognition of other devices"). One or more devices may be faulty; check and, if necessary, replace them.
2 flashes 1 second pause 2 flashes	Photocell activated	At the start of the manoeuvre, one or more photocells do not enable movement; check to see if there are any obstructions. During the movement if there is an obstruction no action is required.
3 flashes 1 second pause 3 flashes	"Gearmotor force" limiting device activated	During the movement, the gate experienced excessive friction; identify the cause.
4 flashes 1 second pause 4 flashes	STOP input activated	At the start of the manoeuvre or during the movement, the STOP input was activated; identify the cause.
5 flashes 1 second pause 5 flashes	Error on internal parameters in electronic control unit	Wait at least 30 seconds, and then try giving a command; if the condition persists it means there is a serious fault and the electronic board must be replaced.
6 flashes 1 second pause 6 flashes	Maximum limit of manoeuvres per hour exceeded	Wait a few minutes until the manoeuvre limiting device falls to below the maximum limit.
7 flashes 1 second pause 7 flashes	Internal electric circuit error	Disconnect all power circuits for a few seconds, and then try giving a command; if the condition persists it means there is a serious fault and the electronic board must be replaced.
8 flashes 1 second pause 8 flashes	A command is already present that disables execution of other commands.	Check the type of command that is always present; for example, it could be a command from a timer on the "open" input.
9 flashes 1 second pause 9 flashes	Blocked automation	Release the automation by giving to the control unit the release automation command.

10.6.3 - Control unit

The LEDs on the control unit provide particular signals to report on the normal operation and on possible faults; see **Table 13**.

TABLE 13 (fig. 46)

LED ECSBus [A]	Status	Action
Off	Fault	Check that the unit is powered; check that the fuses have not been activated; if this is the case check the cause of the fault and replace them with other fuses with the same characteristics.
On	Serious fault	There is a serious fault; switch off the control unit for a few seconds; if the status persists there is a fault and the electronic board must be replaced.

One flash per second	Everything OK	Control unit works correctly.
2 long flashes	Input status variation	A variation to the status of the inputs OPEN, STOP, activation of the photocells, or when the radio transmitter is used, is normal.
1 flash every 2 seconds	Automation in "standby" mode	Everything OK; when the control unit receives a command normal operation is restored (with a short delay).
Series of flashes separated by a pause	The same signal as for the flashing light, see Table 12 .	An overload has been detected therefore the power to the ECSBus switched off. Check by disconnecting the devices one at a time.
Quick flash	ECSBus short circuit	To restore power to the ECSBus simply send a command, for example with a radio transmitter.
LED STOP [B]	Status	Action
Off *	STOP input activated	Check the devices connected to the STOP input
On	Everything OK	STOP input active
LED OPEN [C]	Status	Action
Off	Everything OK	OPEN input not active
On	OPEN input activated	This is normal only if the device connected to the OPEN input is active
LED P1 [D]	Status	Action
Off *	Everything OK	No memorisation underway.
On	Memorisation mode 1	This is normal during memorisation mode 1 which lasts maximum 10 s.
Series of quick flashes, from 1 to 4	Memorisation mode 2	This is normal during memorisation mode 2 which lasts maximum 10 s.
5 quick flashes	Deletion OK	Deletion of a transmitter successfully completed.
1 slow flash	Wrong command	Command received from a transmitter which is not memorised
3 slow flashes	Memorisation OK	Memorisation successfully completed
5 slow flashes	Deletion OK	All radio transmitters successfully deleted
LED P2 [E]	Status	Action
Off *	Everything OK	"Slow" speed selected
On	Everything OK	"Fast" speed selected
1 flash per second	The learning phase has not been carried out or there are errors in the memory data	Carry out the position learning procedure again (see paragraph 10.3.3 "Learning the connected devices")
2 flashes per second	Device learning procedure underway	It shows that the search for connected devices is underway (it lasts maximum a few seconds)
LED P3 [F]	Status	Action
Off *	Everything OK	Cycle operation
On	Everything OK	Complete cycle operation

* or it could be in "Standby" mode

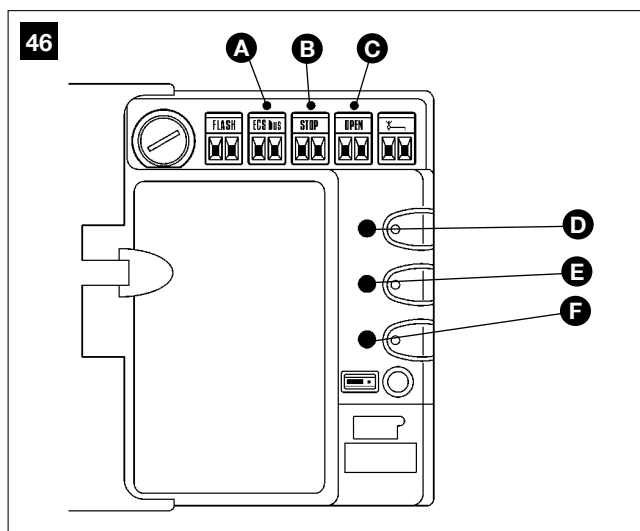

TECHNICAL SPECIFICATIONS OF PRODUCT COMPONENTS

The product SL1S-SL10S is produced by Nice S.p.a. (TV) I, Mhouse is a company part of the NICE S.p.a. group. In order to improve its products, NICE S.p.a. reserves the right to modify the technical characteristics at any time without prior notice. In any case, the manufacturer guarantees their functionality and fitness for the intended purposes. Note: all technical specifications refer to a temperature of 20°C.

Model/type	SL1SC	SL10SC
Product type	Electromechanical gearmotor for the automation of automatic gates and doors with built-in control unit complete with radio receiver for "GTX4" transmitters.	
Adopted technology	24 motor, helical gear reducer; mechanical release. A transformer incorporated inside the motor but separated from the control unit, reduces the mains voltage to the nominal 24 V \approx voltage used in the whole automation system.	
Maximum start-up torque	10 Nm	15 Nm
Nominal torque	3,5 Nm	5,2 Nm
No-load speed	0,25 m/s	0,18 m/s
Speed at nominal torque	0,20 m/s	0,15 m/s
Maximum frequency of cycles	14 cycles/hour at 25 °C	12 cycles/hour at 25 °C
Maximum time continuous cycle	10 minutes	7 minutes
Application limits	The structural design of this product makes it suitable for use on gates with a weight up to 400 kg or leaf width up to 5 m.	The structural design of this product makes it suitable for use on gates with a weight up to 550 kg or leaf width up to 7 m.
Mains power supply SL1SC-SL10SC	230 V \sim (+10% -15%) 50/60Hz	
Mains power supply SL1SC-SL10SC/V1	120 V \sim (+10% -15%) 50/60Hz	
Max. absorbed power	370 W	420 W
Backup power supply	For "PR1" buffer batteries	
Flashing light output	For flashing lights with 12 V (maximum 21 W) bulb	
ECSBus output	1 output with maximum load of 10 ECSBus units	
"OPEN" input	For normally open contacts (closure of the contact prompts the "OPEN" command)	
"STOP" input	For normally open and/or 8,2K Ω constant resistance type contacts, or normally closed contacts with self-learning of the "normal" status (a variation with respect to the memorised status generates a "STOP" command)	
Radio aerial input	52 Ω for RG58 or similar type cable	
Max. cable length	Mains power-supply: 30 m; inputs/outputs: 20 m with antenna cable preferably less than 5 m (observe warnings regarding the minimum section and type of cables)	
Ambient operating temperature	-20 \div 50°C	
Use in particularly acid, saline or potentially explosive atmosphere	NO	
Assembly	Horizontal on a flat surface with the specific fixing plate	
Protection rating	IP44	
Dimensions / weight	300 x 163 h 295 mm / 7,5 kg	300 x 163 h 295 mm / 8,5 kg
Possibility of remote control	With "GTX4" transmitters, the control unit is set to receive one or more of the following commands: "OPEN", "Partial Open", "Only Open" and "Only Close"	
Compatible GTX4 transmitters	Up to 150 if memorised in mode 1	
GTX4 transmitter range	50-100 m. This distance may vary in the presence of obstacles and electromagnetic disturbance present, and is influenced by the position of the receiving antenna built into the flashing light.	
Programmable functions	"Single cycle" or "Complete cycle" (automatic closure) operating mode Motor speed "slow" or "fast" Pause time in "complete cycle" selectable from 10, 20, 40, and 80 seconds Type of partial opening selectable from 4 modes Obstacle detection system sensitivity selectable on 4 levels "Open command" operating mode selectable on 4 modes	
Self-programmed functions	Self-learning of devices connected to the ECSBus output Self-learning of type of "STOP" device (NO, NC or 8,2 K Ω resistance contact) Learning of gate length and calculation of the points of deceleration	

PH100 Photocells	
Product Type	Presence detector for automations of automatic gates and doors (type D according to standard EN 12453) comprising a transmitter "TX" and receiver "RX"
Adopted technology	Optical, by direct interpolation of TX-RX with modulated infra-red rays
Detection capacity	Opaque objects located on the optical axis between TX and RX, larger than 50 mm and moving slower than 1.6 m/s
TX transmission angle	20° approx.
RX reception angle	20° approx.
Useful range	10 m for maximum TX-RX misalignment $\pm 5^\circ$ (the device can signal an obstacle even in the event of particularly adverse weather conditions)
Power supply / output	The device can only be connected to the "ECSBus" networks from which it receives mains power, and sends the output signal
Absorbed power	1 ECSBus unit
Max. cable length	Up to 20 m (observe warnings regarding the minimum section and type of cables)
Possibility of address assignment	Up to 7 detectors with protection function and 2 with opening command function Automatic synchronisation prevents interference between the various detectors
Ambient operating temperature	-20 ÷ 50°C
Use in particularly acid, saline or potentially explosive atmospheres	No
Assembly	Vertical, wall-mounted
Protection rating	IP44
Dimensions / weight	64 x 89,2 h 29 mm / 60 g

FL100 indicator light	
Product Type	Flashing indicator light for automations of automatic gates and doors The device incorporates a receiver aerial for remote control
Adopted technology	Indicator light with 12V 21W lamp controlled by the control units for MHOUSE automations
Lamp	12V 21W fitting BA15 (vehicle type lamp)
Power supply	The device can only be connected to the terminals "FLASH" and "ANTENNA" of the MHOUSE automation control units
Ambient operating temperature	-20 ÷ 50°C
Use in particularly acid, saline or potentially explosive atmospheres	No
Assembly	Horizontal on a flat surface or vertical wall-mounted
Protection rating	IP55
Dimensions / weight	120 x 60 h 170mm / 285g

GTX4 Transmitters	
Product Type	Radio transmitters for remote control of automations for automatic gates and doors
Adopted technology	Encoded AM OOK radio modulation
Frequency	433.92 MHz
Encoding	64 Bit rolling code (18 billion billion combinations)
Keys	4, each key can be used for different commands of the same control unit or to control different control units
Radiated power	0.001 W circa
Power supply	3V +20% -40% with 1 lithium battery type CR2032
Battery life	3 years, estimated on the basis of 10 commands/day lasting 1s at 20°C (battery efficiency is reduced at low temperatures)
Ambient operating temperature	-20 ÷ 50°C
Use in particularly acid, saline or potentially explosive atmospheres	No
Protection rating	IP40 (use in the home or protected environments)
Dimensions / weight	50 x 50 h 17mm / 16g

CE Declaration of Conformity

Declaration in accordance with the Directives: 1999/5/EC (R&TTE), 2004/108/EC (EMC);
2006/42/EC (MD) Appendix II, part B

SL1S and SL10S are produced by NICE S.p.a. (TV) I; MHOUSE is a commercial trademark owned by
the group Nice S.p.a.

Note - The contents of this declaration correspond to declarations in the last revision of the official document deposited at the registered offices of Nice Spa available before this manual was printed. The text herein has been re-edited for editorial purposes. A copy of the original declaration can be requested from Nice S.p.a. (TV) I.

Number: 361/SL1S

Revision: 0

Language: EN

Manufacturer's Name:

NICE s.p.a.

Address:

Via Pezza Alta 13, Z.I. Rustignè, 31046 Oderzo (TV) Italy

**Person authorised to compile
the technical documentation:**

Mr. Oscar Marchetto.

Product type:

Electromechanical gearmotor with built-in control unit and radio receiver

Model / Type:

SL1S, SL10S

Accessories:

GTX4, PH100, KS100, FL100

The undersigned, Luigi Paro, in the role of Managing Director, declares under his sole responsibility, that the above mentioned product conforms to the requirements of the following directives:

- 1999/5/EC DIRECTIVE OF THE EUROPEAN PARLIAMENT AND COUNCIL of th 9th March 1999 regarding radio equipment and telecommunications terminal equipment and the mutual recognition of their conformity, according to the following harmonised standards:
 - Health protection (art. 3(1)(a)): EN 50371:2002
 - Electric safety (art. 3(1)(a)): EN 60950-1:2006
 - Electromagnetic compatibility (art. 3(1)(b)): EN 301 489-1 V1.8.1:2008, EN 301 489-3 V1.4.1:2002
 - Radio spectrum (art. 3(3)): EN 300 220-2 V2.1.2:2007
- DIRECTIVE 2004/108/EC OF THE EUROPEAN PARLIAMENT AND COUNCIL of 15th December 2004 regarding the approximation of member state legislation related to electromagnetic compatibility, repealing directive 89/336/EEC, according to the following harmonised standards:
EN 61000-6-2:2005, EN 61000-6-3:2007

In addition the product conforms to the following directive according to the requirements for "partly completed machinery":

2006/42/EC Directive OF THE EUROPEAN PARLIAMENT AND COUNCIL of 17 May 2006 regarding machinery, repealing directive 95/16/EC

- We hereby declare that the relevant technical documentation has been compiled in conformity with Annex VII B of directive 2006/42/EC and that the following essential requirements have been satisfied:
1.1- 1.1.2- 1.1.3- 1.2.1-1.2.6- 1.5.1-1.5.2- 1.5.5- 1.5.6- 1.5.7- 1.5.8- 1.5.10- 1.5.11
- The manufacturer undertakes to transmit, in response to a reasoned request by the national authorities, relevant information on the "partly completed machinery", without prejudice to intellectual property rights of the manufacturer.
- The manufacturer undertakes to transmit, in response to a reasoned request by the national authorities, relevant information on the "partly completed machinery", without prejudice to intellectual property rights of the manufacturer.
- The "partly completed machinery" must not be put into service until the final machinery into which it is to be incorporated has been declared in conformity with the provisions of directive 2006/42/EC.

Furthermore, the product conforms to the following standards:

EN 60335-1:2002 + A1:2004 + A11:2004 + A12:2006 + A2:2006 + A13:2008
EN 60335-2-103:2003

The product also complies, within the constraints of applicable parts, with the following standards:

EN 13241-1:2003, EN 12445:2002, EN 12453:2002, EN 12978:2003

Oderzo, 29 July 2010

Ing. Luigi Paro (Managing Director)



— STEP 11 —

This guide must be stored safely and be accessible to all automation users.

11.1 – Safety instructions

- **Keep at a safe distance from the moving door until it is completely open or closed; do not go through the door until it is completely open and has come to a standstill.**
- **Do not allow children to play near the door or with the controls.**
- **Keep the transmitters away from children.**

- **Suspend the use of the automation immediately as soon as you notice something abnormal in the operation (noises or jolting movements); failure to follow this warning may cause serious danger and accidents.**

- **Do not touch moving parts.**

- **Regular maintenance checks must be carried out by qualified personnel according to the maintenance plan.**

- **Maintenance or repairs must only be carried out by qualified technical personnel.**

11.2 – Gate control

• With radio transmitter

The radio transmitter supplied is ready for use and the four keys have the following functions (fig. 47):

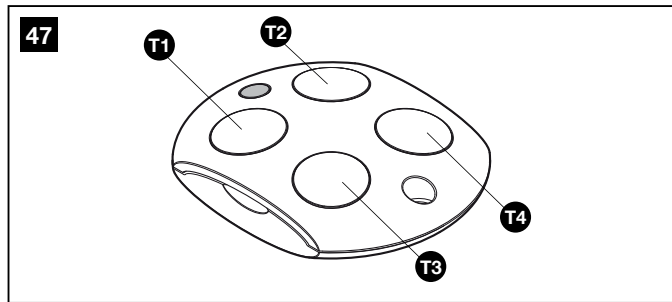

Function(*)	
Key T1	
Key T2	
Key T3	
Key T4	

(*) This table must be compiled by the person who programmed the automation.

• With selector (optional accessory)

The selector has two positions with automatic return to the centre (fig. 48).

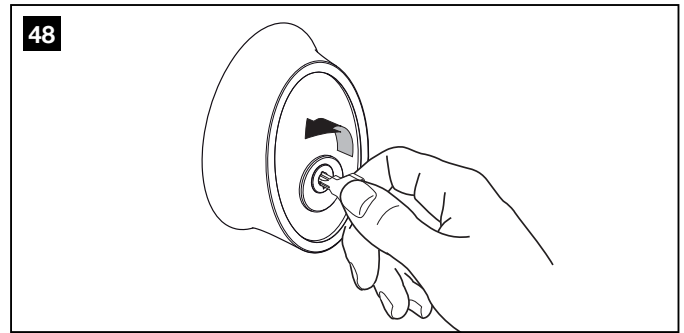

Action	Function
Turned right: "OPEN"	(*)
Turned left: "STOP"	Stops movement of the sectional or up-and-over door

(*) This item must be compiled by the person who programmed the automation.

• Control with safety devices out of service

In the event of safety devices malfunctioning or out of service, the door may still be moved.

- 01.** Activates the gate command (with remote control or key-operated selector switch). The door will open normally if there is the consent of the safety devices, otherwise the command must be activated and held within 3 seconds.
- 02.** After about 2 s the door will move in "hold-to-run" mode, in other words until the command is pressed the door will continue to move; the door will stop as soon as the command is released.

In the event of safety devices out of service arrange for repairs to the automation immediately.

11.3 – Manually releasing or locking the gearmotor (fig. 49)

SL1S-SL10S are equipped with a mechanical system that enables manual opening and closing of the gate (i.e. as if there is not a gearmotor).

The manual operation must be carried out in case of power failure or system malfunction. In case of power failure the buffer battery can be used (optional accessory PR1).

In case of fault of the gearmotor the motor release can be used to check whether the fault is in the release mechanism.

- 01.** Turn the release cap cover anti-clockwise until it coincides with the hole with the release pin.
- 02.** Insert the key in the release pin.
- 03.** Turn the key anti-clockwise by about 90° until the gate is released.
- 04.** Then move the gate manually.

05. To reset the automation turn the key clockwise and at the same time move the gate until you hear the carriage .

06. Remove the key and close the release cap cover by turning it clockwise.

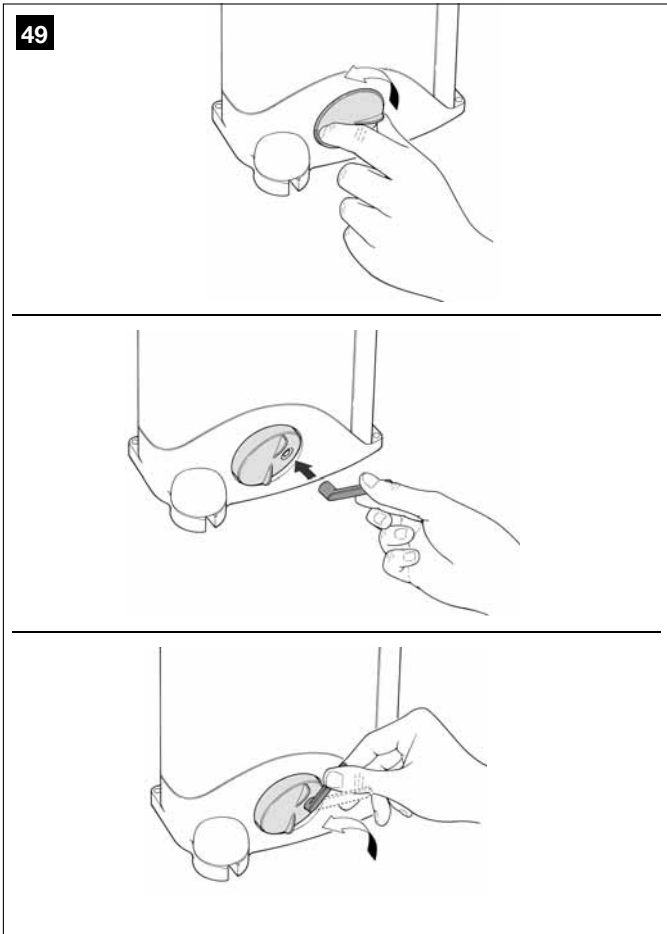

11.4 – Maintenance operations admissible to the user

The list of operations to be regularly carried out by the user is listed below.

- For cleaning the surfaces of the devices, use a slightly damp (not wet) cloth. Never use substances containing alcohol, benzene, diluents or other flammable substances. Use of these substances may damage the devices and cause fires or electric shocks.

- Disconnect the automation from the power supply before removing leaves or stones to stop anyone activating the door.

11.5 – Remote control battery replacement (fig. 50)

When the battery charge is low, the transmitter range is reduced significantly. When a key is pressed, if led L1 illuminates and then immediately fades and turns off, this means that the battery is completely discharged and must be replaced immediately.

Otherwise if led L1 illuminates briefly, this means that the battery charge is low; in this case press and hold the key for at least half a second to enable the transmitter to attempt delivery of the command. In any event, if the battery charge is too low to complete a command (and wait for a response) led L1 fades and the transmitter turns off. In these cases, to restore normal operation of the transmitter, replace the old battery with a new version of the same type, taking care to observe the specified polarity. To replace the battery, proceed as shown in fig. 50.

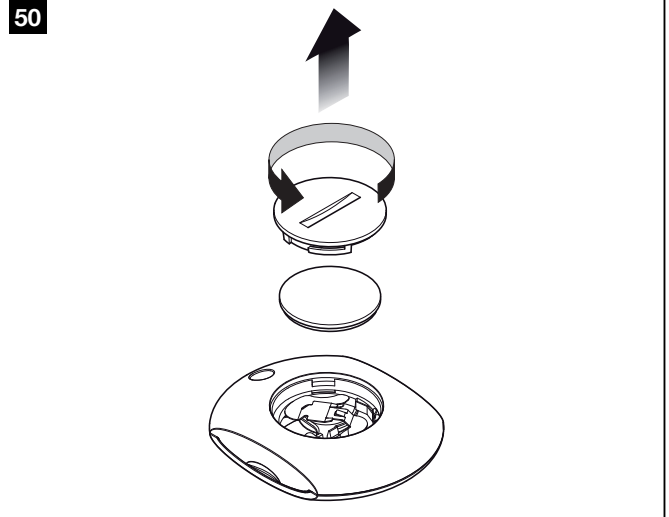

The batteries contain pollutant substances: do not dispose of them with normal waste material; follow the instructions foreseen by local regulations.

11.6 – Installing the remote control support

To install the remote control support, see fig. 51.

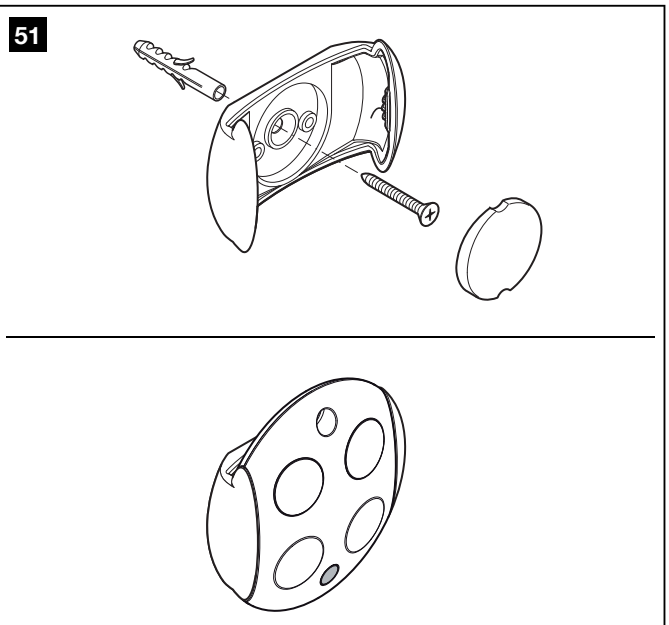

CE DECLARATION OF CONFORMITY

In conformity with Directive 2006/42/EC, APPENDIX II, part A (EC declaration of conformity for machinery)

The undersigned/company *(name or company name of the person responsible for commissioning of the power-operated gate):*

.....

Address:

.....

Hereby declares under his/her sole responsibility that:

- **The automation:** power-operated swing gate
 - **Serial N°:**
 - **Year of manufacture:**
 - **Location (address):**
-

Complies with the essential requirements of the following directives:

- 2006/42/CE** "Machinery" Directive
- 2004/108/CEE** Electromagnetic compatibility directive
- 2006/95/CEE** "Low Voltage" Directive
- 1999/5/CE** "R&TTE" Directive

and what is provided for by the following harmonised standards:

- EN 12445** "Industrial, commercial and garage doors and gates. Safety in use of power operated doors - Test methods"
- EN 12453** "Industrial, commercial and garage doors and gates. Safety in use of power operated doors - Requirements"

Name: Signature:

Date:

Place:



Downee

Exclusive Australian Distributor

Customer Service (03) 9364 8288

See downee.com.au for your state office

Tech Support 1800 241 733 techsupport@downee.com.au

downee.com.au

Mhouse is a commercial trademark owned by Nice S.p.a.

Nice S.p.a.

Via Pezza Alta, 13 - Z.I. Rustignè

31046 Oderzo (TV), Italia

Tel. +39 0422 85 38 38

Fax +39 0422 85 35 85

