

AVIO600

AVIO1000

CE

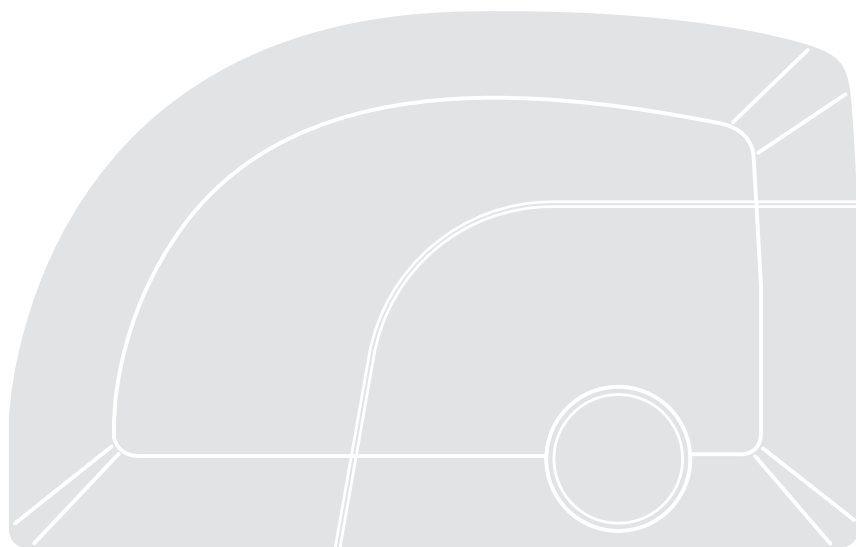

Motorisation pour portes de garage

FR - Instructions et avertissements pour l'installation et l'utilisation

EN - Instructions and warnings for installation and use

IT - Istruzioni ed avvertenze per l'installazione e l'uso

PL - Instrukcje i ostrzeżenia do instalacji i użytkowania

Nice Your
Smart
Home

— STEP 1 —

CAUTION - Important safety instructions. Observe all the instructions as improper installation may cause serious damage

CAUTION - Important safety instructions. It is important to comply with these instructions to ensure personal safety. Store these instructions

- Before commencing the installation, check the "Product technical specifications", in particular whether this product is suitable for automating your guided part. Should it be unsuitable, DO NOT proceed with the installation
- The product cannot be used before it has been commissioned as specified in the "Testing and commissioning" chapter

CAUTION - According to the most recent European legislation, the implementation of an automation system must comply with the harmonised standards set forth in the Machinery Directive in force, which allow for declaring the presumed conformity of the automation. On account of this, all operations regarding connection to the mains electricity, as well as product testing, commissioning and maintenance, must be performed exclusively by a qualified and skilled technician!

- Before proceeding with the product's installation, check that all materials are in good working order and are suitable for the intended applications
- The product is not intended for use by persons (including children) with reduced physical, sensory or mental capacities, nor by anyone lacking sufficient experience or familiarity with the product
- Children must not play with the appliance
- Do not allow children to play with the control devices of the product. Keep the remote controls out of reach of children

CAUTION - In order to avoid any danger from inadvertent resetting of the thermal cut-off device, this appliance must not be powered through an external switching device, such as a timer, or connected to a supply that is regularly powered or switched off by the circuit

- Provide a disconnection device (not supplied) in the plant's mains power supply, with a contact opening distance that ensures complete disconnection under the conditions envisaged by Overvoltage Category III
- Handle the product with care during installation, taking care to avoid crushing, knocks, falls or contact with liquids of any kind. Keep the product away from sources of heat and open flames. Failure to observe the above can damage the product and increase the risk of danger or malfunctions. If this should happen, stop installation immediately and contact the Customer Service
- The manufacturer assumes no liability for damage to property, items or persons resulting from non-compliance with the assembly instructions. In such cases the warranty does not cover material defects
- The weighted sound pressure level of the emission A is lower than 70 dB(A)
- Cleaning and maintenance to be carried out by the user must not be effected by unsupervised children
- Before intervening on the system (maintenance, cleaning), always disconnect the product from the mains power supply
- Check the system periodically, in particular all cables, springs and supports to detect possible imbalances, signs of wear or damage. Do not use if repairs or adjustments are necessary, because a failure with the installation or an incorrectly balanced automated system may lead to injury
- The packaging materials of the product must be disposed of in compliance with local regulations
- Keep persons away from the gate when it is moved through the control elements
- When performing a manoeuvre, keep an eye on the automated mechanism and keep all bystanders at a safe distance until the movement has been completed
- Do not operate the automation if anyone is working on it; disconnect the power supply before permitting any work to be carried out

INSTALLATION PRECAUTIONS

- Prior to installing the drive motor, check that all mechanical components are in good working order and properly balanced, and that the automation moves correctly
- If the door being automated has a pedestrian door, the system must include a control device inhibiting the operation of the motor when the pedestrian door is open
- Make sure that the controls are kept at a safe distance from moving parts, while allowing a good view of these.
- Unless a selector is used, the controls should be installed at least 1.5

- m from the ground and must not be accessible
- If the opening movement is controlled by a fire-prevention system, make sure that any windows larger than 200 mm are closed by the control elements
- Prevent and avoid any form of trapping between the moving and fixed parts during manoeuvres
- Permanently affix the manual operation label next to the element enabling the manoeuvre itself
- After installing the drive motor, make sure that the mechanism, protective system and all manual manoeuvres operate properly

PRODUCT DESCRIPTION

— STEP 2 —

2.1 – APPLICATIONS

AVIO is a line of gearmotors designed for the automation of sectional doors and the suitable GA2 accessory, not supplied, or overhead (springs or counterweights) doors.

Any applications other than those described above or in different conditions from those specified in this manual are forbidden.

AVIO operates with electric power. In the event of a power failure, the gearmotor can be released using a suitable cord in order to move the door manually.

As an alternative, the optional accessory can be used on the AVIO1000 model: PR100 buffer battery.

TABLE 1 - Comparison of main features of the AVIO gearmotors

Gearmotor type	AVIO600	AVIO1000
Maximum torque (corresponding to the maximum force)	10,8 Nm (600 N)	18 Nm (1000 N)
Max. No. of ECSEBus units	1	6
Emergency power supply	No	with PR100
Guide length	3x1m	4x1m

2.2 – DESCRIPTION OF THE AUTOMATION

To clarify a few terms and aspects of a sectional or overhead door automation system: in Figure 1 we provide an example of a typical AVIO600 or AVIO1000 application:

- A) FL200 flashing light with incorporated aerial (optional)
- B) Pair of PH200 photocells (optional)
- C) Mechanical stops
- D) GD102 or GD103 gearmotor

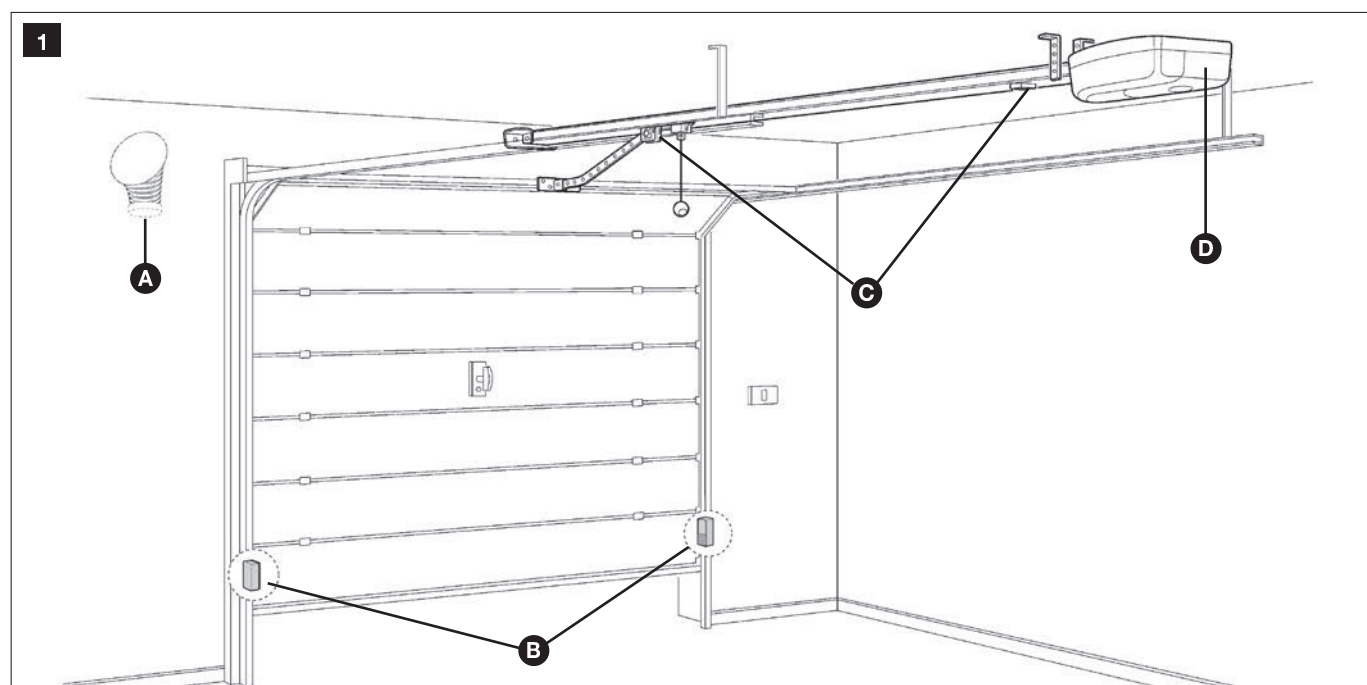

2.3 – DESCRIPTION OF DEVICES

AVIO600 and AVIO1000 can be made-up of the devices shown in Fig. 2; make immediately sure that they correspond to the contents of the package and verify the integrity of the devices.

Note: to adapt AVIO600 and AVIO1000 to local regulations, the contents of the package may vary; an exact list of the contents is shown on the outside of the package. Anyhow, please consult the sales manager.

TABLE 2 - Component and accessory list

Reference	AVIO600	AVIO1000
a	1 GD102 electromechanical gearmotor with incorporated control unit	1 GD103 electromechanical gearmotor with incorporated control unit
b	1 3-metre guide with pre-assembled belt.	1 4-metre guide with pre-assembled belt.
c	2 coupling profiles	3 coupling profiles
d	2 ceiling-mounted brackets	4 ceiling-mounted brackets
e	Miscellaneous small parts: screws, washers, etc. see tables 1, 2, 3 and 4 (*)	Miscellaneous small parts: screws, washers, etc. see tables 1, 2, 3 and 4 (*).
f	2 ECCO5... radio transmitters	2 ECCO5... radio transmitters
g	PH200 pair of wall-mounted photocells	PH200 pair of wall-mounted photocells
h	FL200 flashing light with incorporated aerial	FL200 flashing light with incorporated aerial

* The screws required for mounting AVIO600 and AVIO1000 are not supplied as they depend on the type of material and its thickness

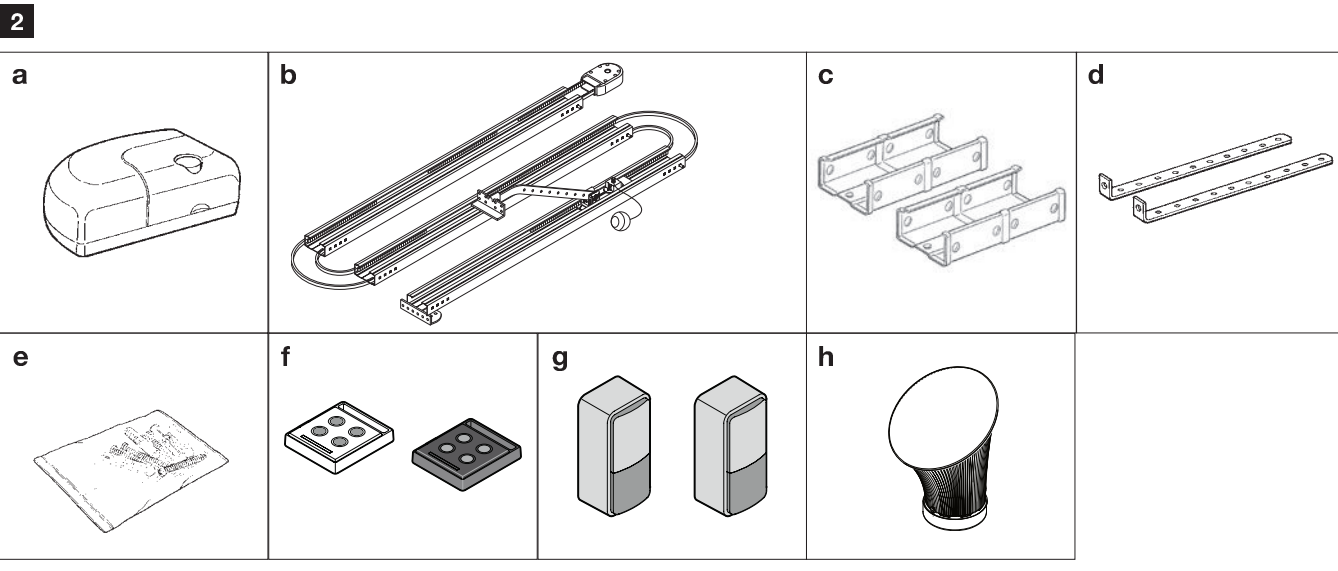

2.3.1 – GD102 and GD103 Electromechanical Gearmotor

GD102 and GD103 are electromechanical gearmotors made up of a 24Vdc motor. They feature a mechanical release mechanism with cord that allows you to move the door manually in the event of a power failure. The gearmotor is fixed to the ceiling with the relative mounting brackets. The PR100 buffer battery can be used on the AVIO1000 version, which allows some manoeuvres in the absence of the mains power supply.

The control unit actuates the gearmotor and provides for the control of the supply of the different components; it features an electronic board with incorporated radio receiver.

The control unit can actuate the gearmotor with two speeds: “slow” or “fast”.

Fig. 3:

The three P1, P2 and P3 buttons [B] and the corresponding LEDs are used to program the control unit.

The yellow button [C] allows the door to be controlled during testing. The same key will also be operated during daily use, through the incorporated orange button [D].

To facilitate the electrical connections there are separate terminals for each device [A], which are removable and colour-coded based on the function performed. Next to each input terminal there is a LED that signals its status.

The connection to the power supply is very easy: just insert the plug in a power outlet.

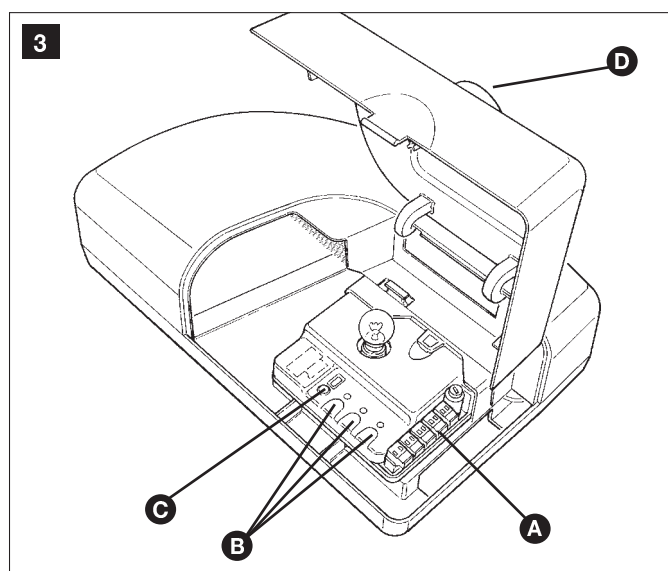

2.3.2 – PH200 photocells (optional)

The pair of PH200 wall-mounted photocells, once they are connected to the control unit, enables the detection of obstacles found on the optical axis between the transmitter (TX) and the receiver (RX).

TABLE 3		
List of small parts	GD102	GD103
M6 self-tapping nuts	Pcs 2	Pcs 4
M6 x14 screws	Pcs 2	Pcs 4
6,3x38 tcei screws	Pcs 4	Pcs 4

TABLE 4	
List of small parts for PH200	Q.ty
HI LO 4X9,5 screw	Pcs 4
3,5X25 self-tapping screw	Pcs 4
s 5 c nylon screw anchor	Pcs 4

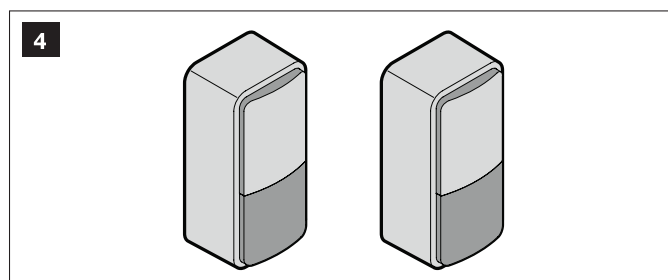

2.3.4 – FL200 flashing light with incorporated aerial (optional)

The flashing light is controlled by the control unit and signals danger when the door is moving. Inside the flashing light there is also the aerial for the radio receiver.

TABLE 6	
List of small parts for FL200	Q.ty
4,2X32 self-tapping screw	Pcs 4
s 6 c nylon screw anchor	Pcs 4

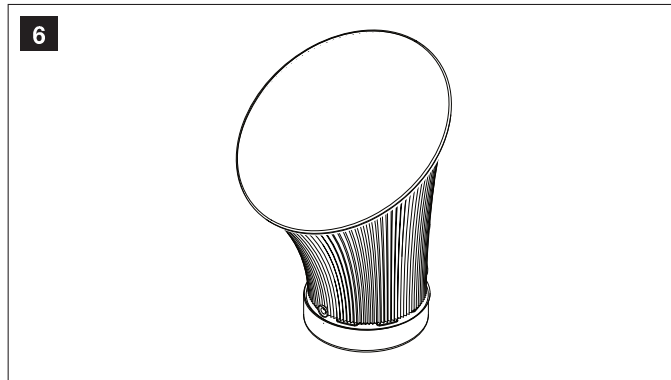

2.3.5 – ECCO5... radio transmitter

The radio transmitter is used for the remote control of the door opening and closing manoeuvres. It features 5 buttons (T5: not used in this application) that can all be used for the 4 types of command to a single automation unit, or to control up to 4 different automation units.

The transmission of the command is confirmed by the LED [A]; an eyelet [B] allows them to be hung on a keyring.

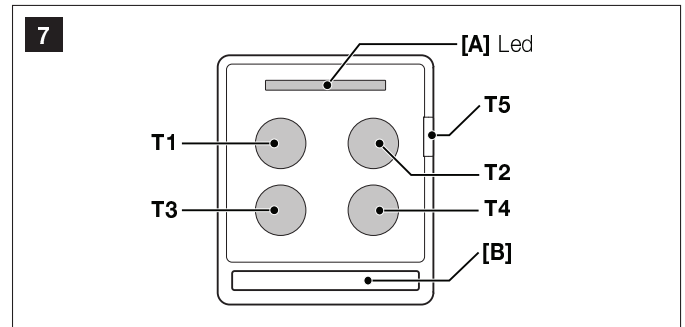

INSTALLATION

— STEP 3 —

⚠ The installation must be carried out by qualified and skilled personnel in compliance with the directions provided in chapter 1 “WARNINGS”.

3.1 – PRELIMINARY CHECKS

AVIO600 and AVIO1000 must not be used to power a door that is not efficient and safe and cannot solve defects resulting from incorrect installation or poor maintenance of the door itself.

WARNING: incorrect installation could cause serious damage.

Before proceeding with the installation you must:

- Make sure that the door movement does not hinder roads or public footpaths.
- After the motor has been installed, remove unnecessary cables or chains and turn off any unneeded equipment.
- Make sure that the weight and dimensions of the door fall within the specified operating limits (Chapter 3.1.1). If they do not, AVIO cannot be used.

- Make sure that the structure of the door is suitable for automation and in compliance with regulations in force.
- Make sure that there are no points of greater friction in the opening or closing stroke of the door.
- Make sure that the mechanical structure of the door is sturdy enough and that there is no risk of it derailing out of the guides.
- Make sure that the door is well balanced: it must not move by itself when it is placed in any position.
- Make sure that the installation area is compatible with the size of the gearmotor and that it is safe and easy to release.
- Make sure that the mounting positions of the various devices are protected from impacts and that the mounting surfaces are sufficiently sturdy.
- Make sure that the mounting surfaces of the photocells are flat and that they enable the proper alignment between TX and RX.
- Pay attention in particular to the methods for securing the head of the guide and the brackets to the ceiling. The head of the guide will have to bear all the strain of opening and closing the door; the ceiling-mounted brackets will have to bear all the weight of AVIO.

In both cases, the wear and deformations which may occur in time must be taken into consideration.

- Make sure that the minimum and maximum clearances specified in fig. 8 are observed.

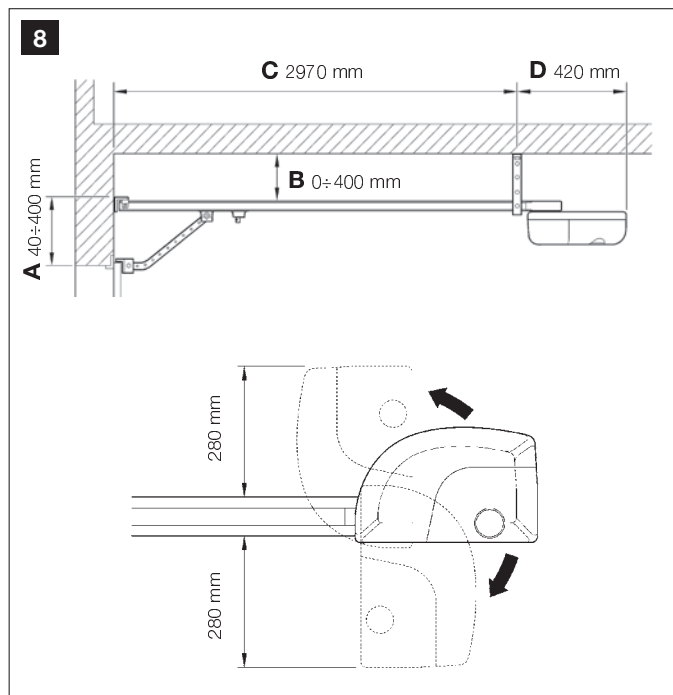

- The gearmotor should be mounted so that it coincides with the centre of the door, or is slightly off-centre. E.g. in order to mount the OSCILLATING ARM next to the handle (Figure 9).

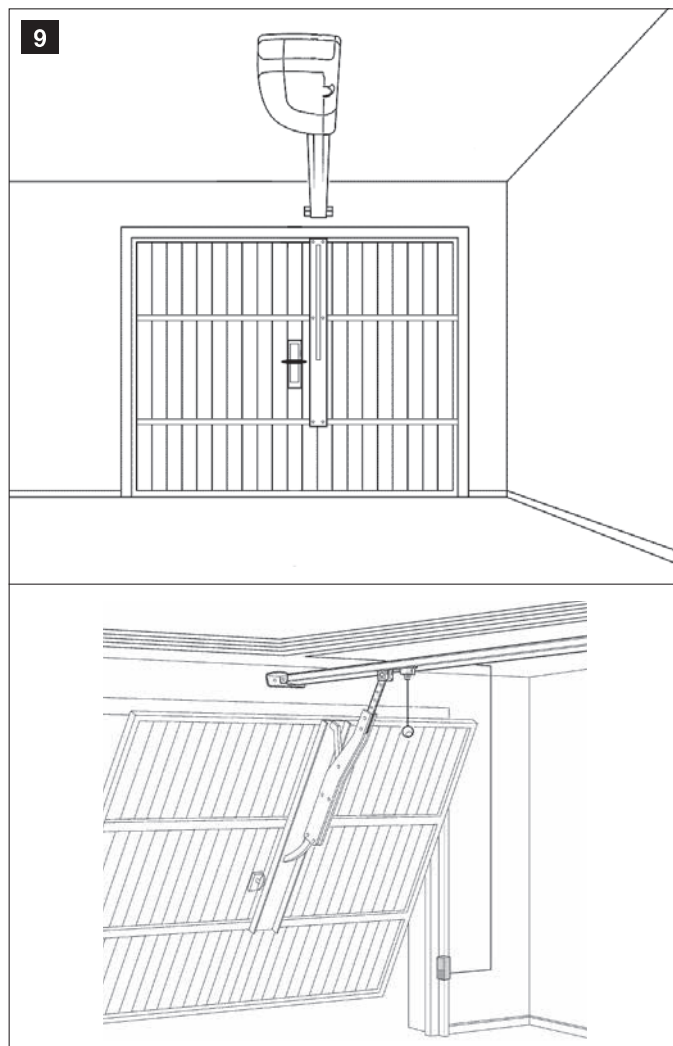

- Make sure that, in the position corresponding to the door, or slightly to the side, (see positions "A" and "B") the conditions are suitable for mounting the head of the guide; in particular, the material should be sufficiently sturdy and compact.

Make sure that AVIO can be mounted on the ceiling along position "C" using the mounting brackets.

If the door to be automated is an overhead type with springs or counterweights, it will be necessary to install a GA2 OSCILLATING ARM, which must be mounted next to the handle (Figure 9).

- Make sure that distance [E] in Figure 10, i.e. the minimum distance between the upper side of the guide and the maximum point reached by the upper edge of the door, is no shorter than 65 mm and no longer than 100 mm, otherwise AVIO cannot be installed.

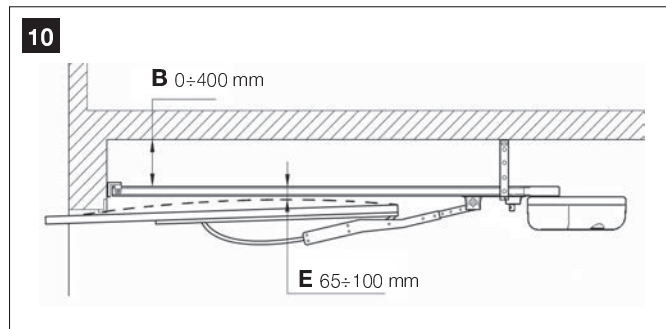

If the door closes a room that has no other means of access, we recommend installation of the GU2 EXTERNAL RELEASE KIT (Figure 11). Otherwise a fault or, for the AVIO600 version with buffer batteries, a simple power failure could prevent access to the room. Note: the oscillating arm and external release kit are supplied with the related assembly instructions.

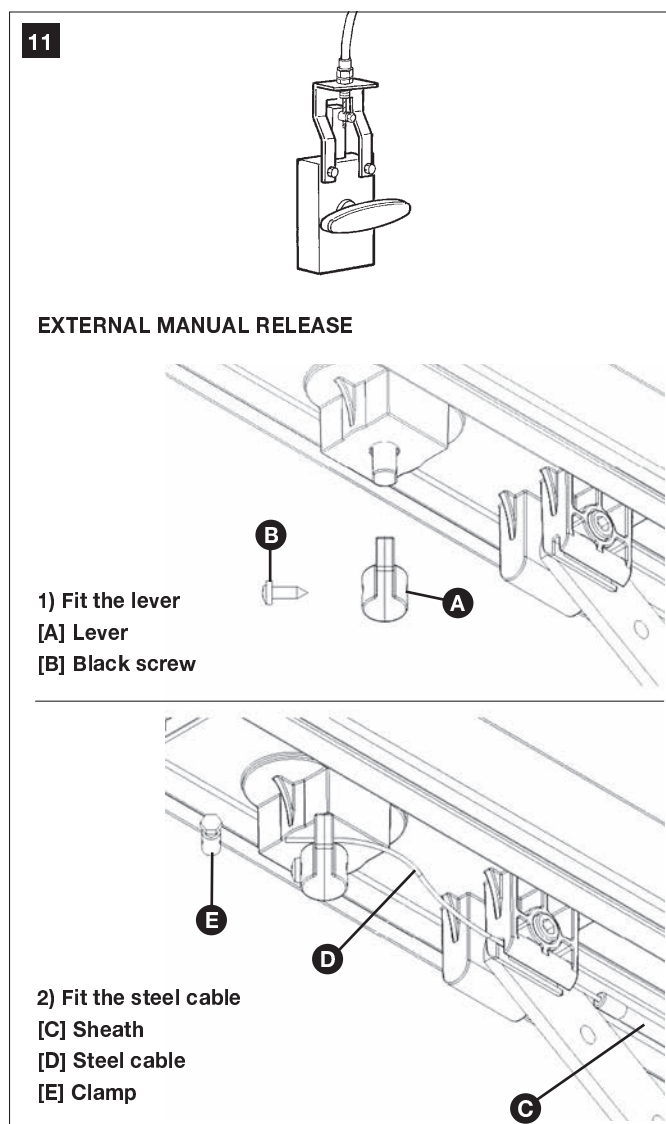

3.1.1 – Operating Limits

Chapter 6 “Technical Characteristics” provides the fundamental data needed to determine whether all the AVIO600 and AVIO1000 components are suitable for the intended application. In general AVIO600 and AVIO1000 are suitable for the automation of sectional and overhead

doors for residential applications having the values shown in the table 7. The shape of the door and the climatic conditions (e.g. presence of strong wind) may reduce this maximum limit. In this case it is necessary to measure the torque needed to move the door under the worst conditions, and to compare it to the data provided in the technical characteristics chart.

TABLE 7

Model	Maximum force	SECTIONAL door		OVERHEAD door non-protruding (with GA2)		OVERHEAD door protruding (with GA2) or with springs (without GA2)	
		Height	Width	Height	Width	Height	Width
AVIO600	600N	2,4m	4,4m	2,2m	4,2m	2,8m	4,2m
AVIO1000	1000N	3,4m	5,2m	3,2m	5m	3,5m	5m

3.1.2 – Tools and Materials

! Make sure you have all the tools and materials needed to install the system; make sure that they are in good condition and serviceable according to current safety standards. See examples in figure 12.

12

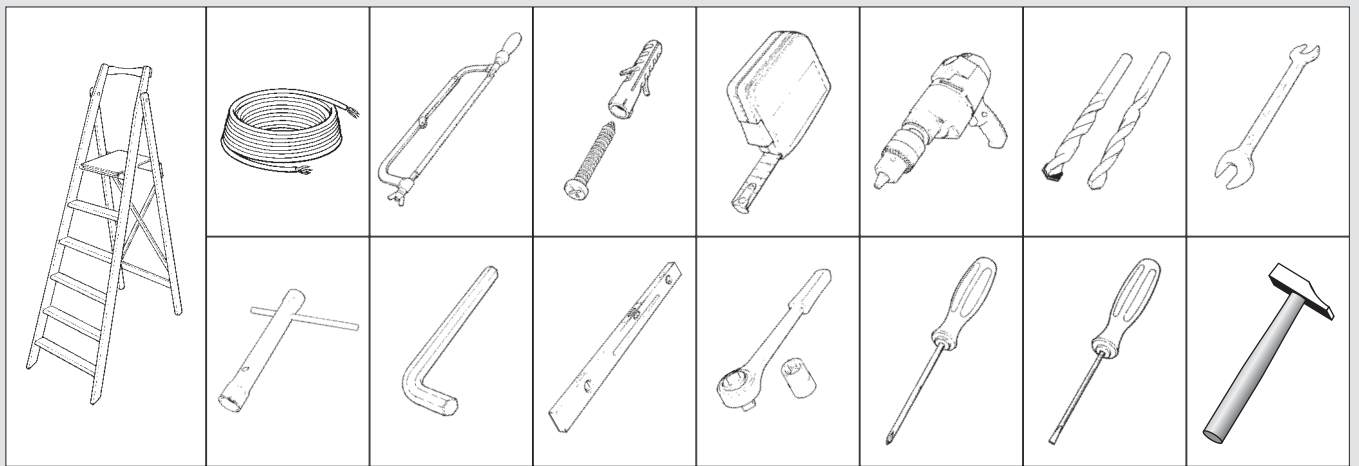

3.1.3 – List of cables

The cables required for the installation of AVIO may vary depending on the type and quantity of devices to be installed; figure 13 shows the cables needed for a typical installation; no cable is supplied with AVIO.

13

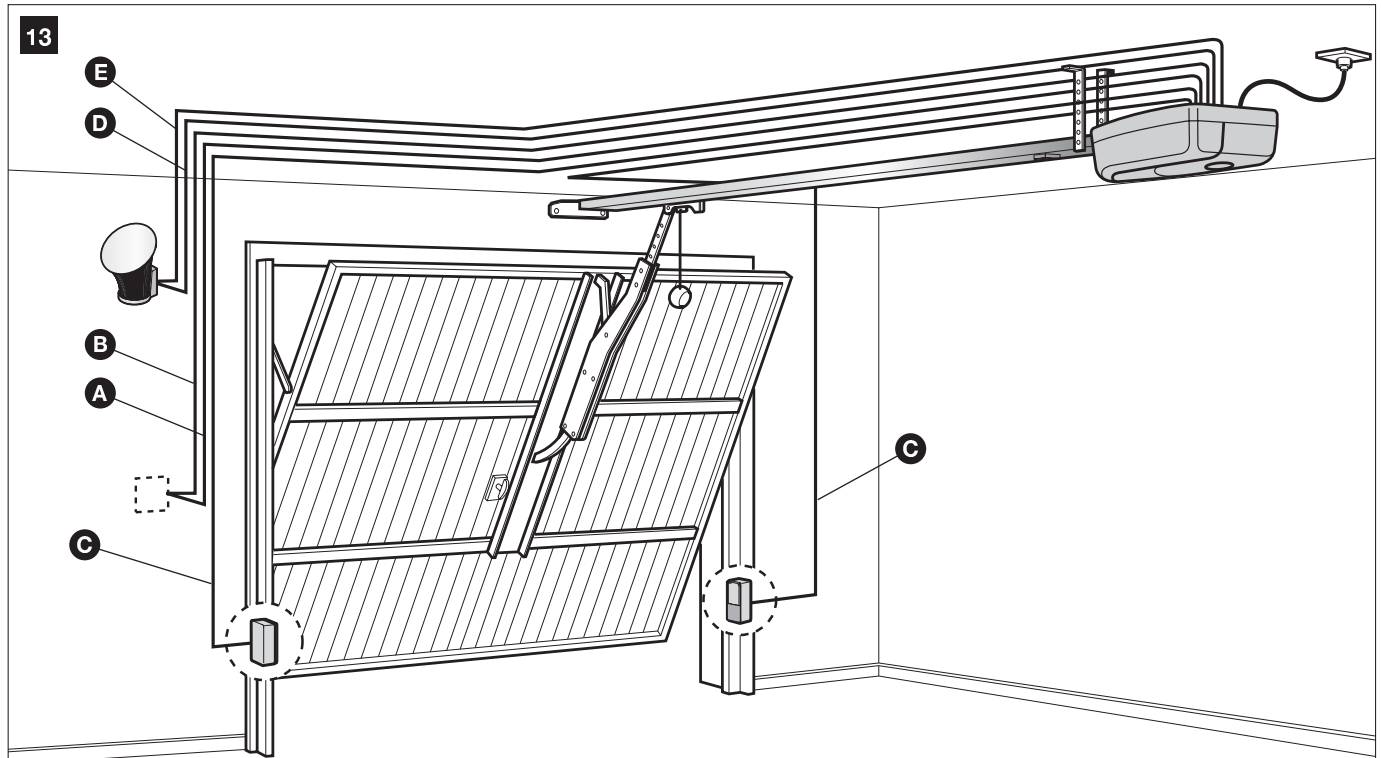

Table 8: List of cables

Connection	Cable type	Maximum length allowed
[A] STOP input	2 x 0,5 mm ² cable	20 m (note 1)
[B] SbS input	2 x 0,5 mm ² cable	20 m (note 1)
[C] BUS input/output	TX 2 x 0,5 mm ² cable	20 m (note 1)
[D] FLASH light output	2 x 0,5 mm ² cable	20 m
[E] Radio aerial	RG58 type shielded cable	20 m (less than 5m recommended)

Note 1 – For the BUS, STOP and SbS cables, there are no special contraindications to the use of a single cable that groups together multiple connections; for example, a single 4x0,5mm² cable.

WARNING! – the cables used must be suitable for the type of installation; for example, an H03VV-F type cable is recommended for indoor applications.

3.2 – PREPARING THE ELECTRICAL SYSTEM

With the exception of the plug and the power cable, the rest of the system uses extra-low voltage (approx. 24V); the wiring can therefore be done by personnel that is not properly qualified, provided that all the instructions in this manual are carefully observed.

After selecting the position of the various devices (refer to figure 13) you can start preparing the conduits for the electrical cables connecting the devices to the control unit.

The shock-resistant conduits are designed to protect the electrical cables and prevent accidental breakage.

3.2.1 – Connection to the Electrical Mains

Although the connection of AVIO to the electrical mains is beyond the scope of this manual, we wish to remind you that:

- The power supply line must be laid and connected by a qualified professional electrician.
- Have a suitably protected 16A “schuko” outlet installed, where you can plug in AVIO.
- Make sure that the power supply cable does not hang over moving parts or hazardous areas.

3.3 – INSTALLATION OF THE VARIOUS DEVICES

Depending on the model, the installation of AVIO is comprised of the following parts:

- Assembly of the guide supplied with AVIO600 (see paragraph 3.3.1).
- Assembly of the guide supplied with AVIO1000 (see paragraph 3.3.2).
- Fixing of the gearmotor to the guide (see paragraph 3.3.3).
- Fixing of the gearmotor to the ceiling (see paragraph 3.3.4).

3.3.1 – AVIO600 guide assembly

The guide supplied with AVIO600 must be assembled as follows:

1. Slacken the adjustment screw of the belt tensioner device before assembling the guide, as in figure 14.
2. Remove the belt from the three pieces that make up the guide (excluding the part next to the pulley) and place them to one side.

3. With the aid of a hammer, assemble the three pieces of the guide engaging them into the connection brackets [A] with force, as in figure 15.

Important – the guides must slide into the brackets until they click into position.

4. Carefully reposition the belt into the guide, making sure that it is not twisted.
5. Connect the head [B] with force into the guide, as in figure 16.
6. Finally, tension the belt with the adjustment screw [C] of the belt tensioner device, as in figure 16a.

Warning - The gearmotor could break if the belt is too TAUT; if it is too SLACK, it could cause unpleasant noise.

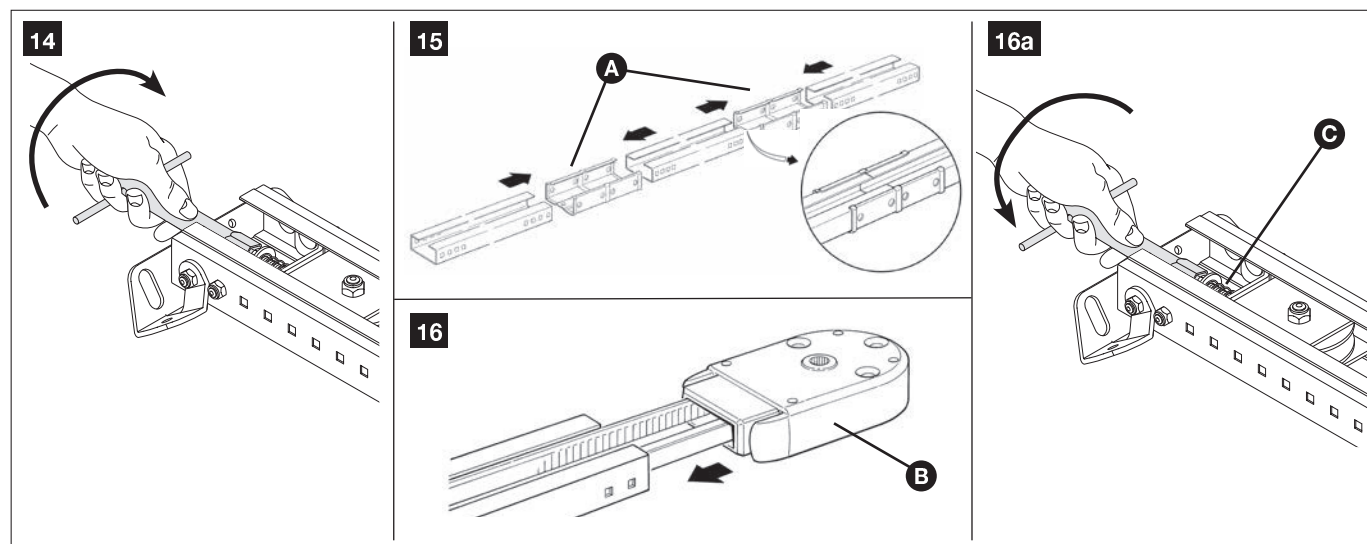

3.3.2 – Assembly of the guide supplied with AVIO1000

The guide is made up of four 1 m long profiles, which permit 2 versions to be made:

3m VERSION:

If the height of the door to be automated is equal to or less than 2,5 m assemble the guide as follows:

1 Cut the free end of the belt to obtain a length of exactly 2 metres, as shown in figure 17.

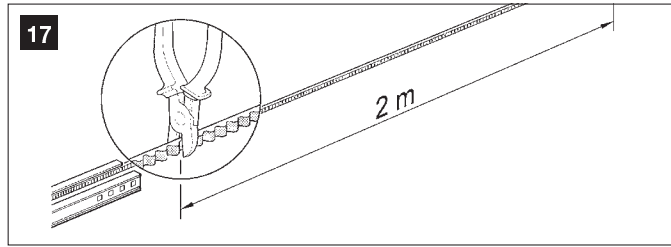

2 Loosen the M8 nut [C] completely, as shown in figure 18.

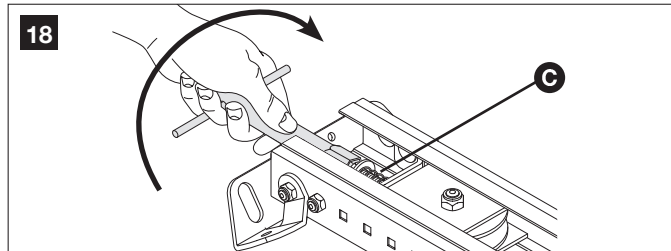

3 Slide the belt tensioner device to mid-stroke [D], as shown in figure 19, and remove the carriage completely.

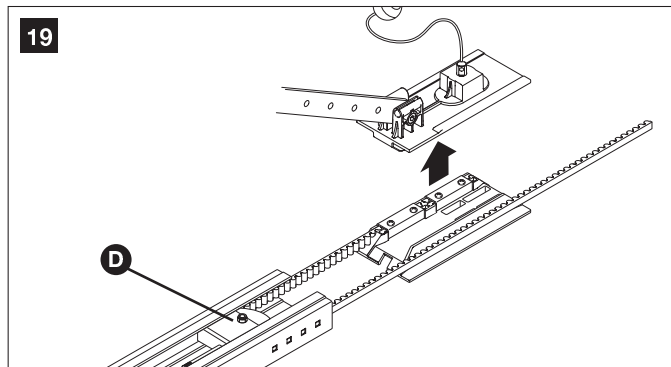

4 Pass the free end of the belt through the head section, as shown in figure 20, and secure it to the carriage by means of the screws and washers present, as shown in figure 21. Take care when positioning the belt: it must be with the teeth facing inwards, straight and without twists.

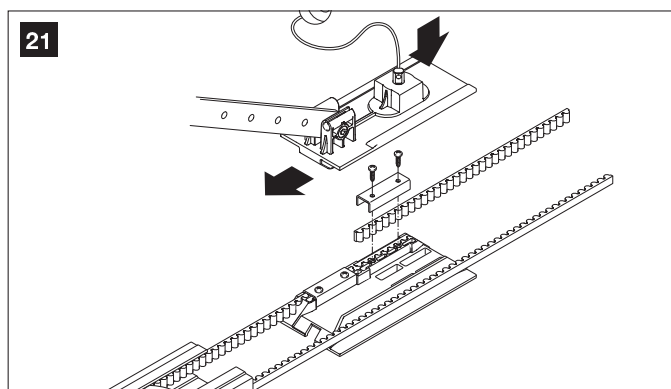
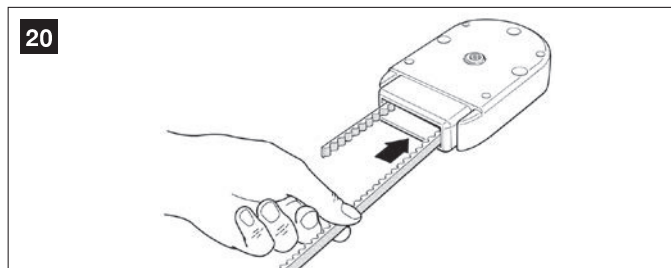

5 With the aid of a hammer, assemble the three pieces of the guide engaging them into the connection brackets [A] with force, as in figures 22 and 22a.

Important – the guides must slide into the brackets until they click into position.

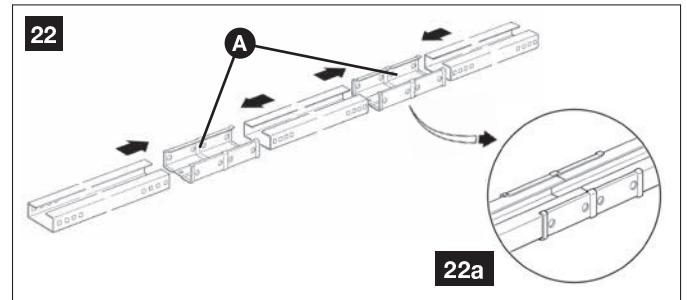

6 Return the belt tensioner device and carriage to the initial position. Assemble the guide head section [B], as shown in figure 23. This requires a certain force; if necessary use a rubber mallet.

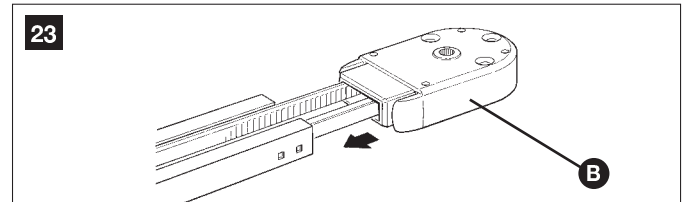

7 Insert the spring, washer and M8 nut [C] in the screw of the belt tensioner device, as shown in figure 24.

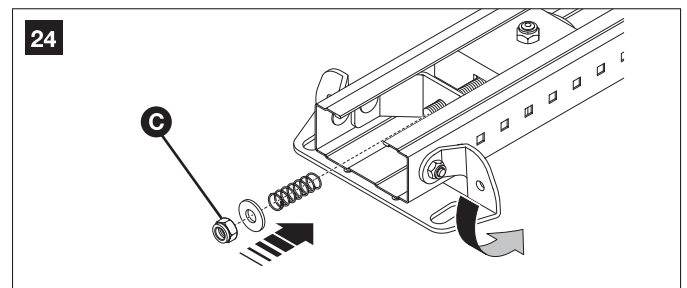

8 Tension the belt by means of the M8 nut [C] (figure 25) until it is sufficiently taut.

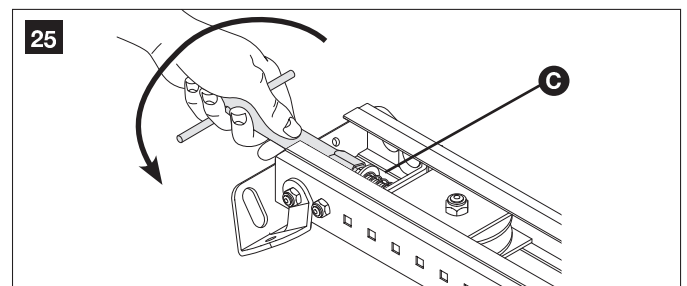

4m VERSION:

If the height of the door to be automated is greater than 2,5m assemble the guide as follows:

1 Loosen the M8 nut [C] completely, as shown in figure 26.

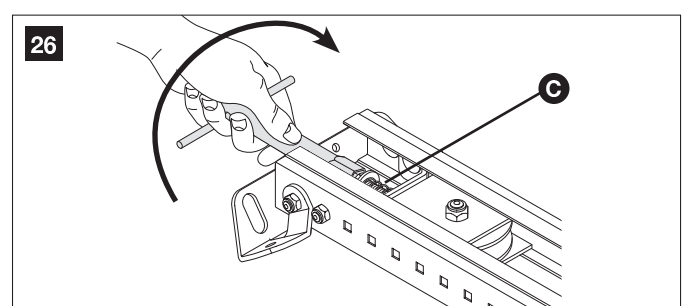

2 Slide the belt tensioner device to mid-stroke [D], as shown in figure 27, and remove the carriage completely.

27

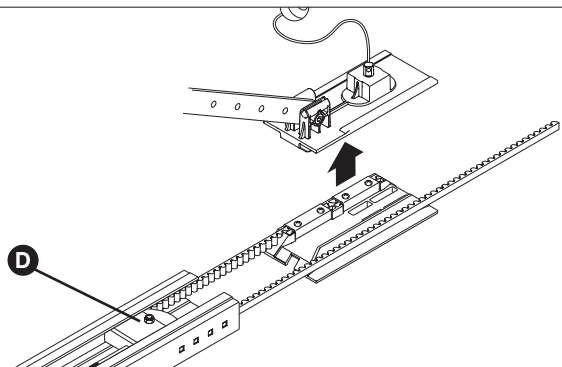

3 Pass the free end of the belt through the head section, as shown in figure 28, and secure it to the carriage by means of the screws and washers present, as shown in figure 29. Take care when positioning the belt: it must be with the teeth facing inwards, straight and without twists.

28

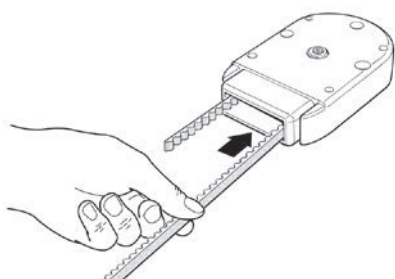

29

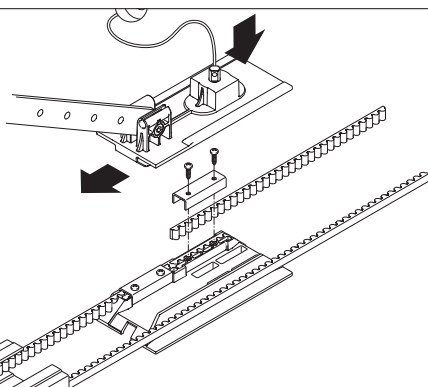

4 With the aid of a hammer, assemble the four pieces of the guide into the three connection brackets [A], as in figures 30.

Important – The guides must slide into the brackets until they click into position.

30

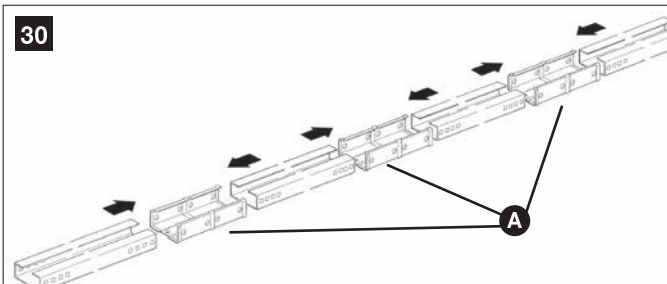

5 Return the belt tensioner device and carriage to the initial position. Assemble the guide head section [B], as shown in figure 31. This requires a certain force; if necessary use a rubber mallet.

31

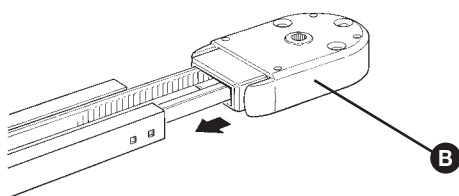

6 Insert the spring, washer and M8 nut [C] in the screw of the belt tensioner device, as shown in figure 32.

32

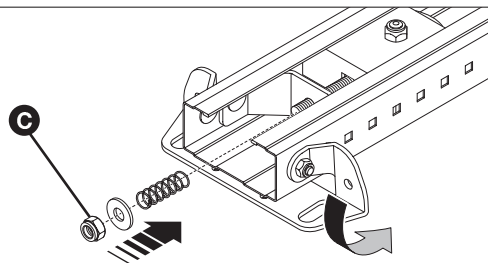

7 Tension the belt by means of the M8 nut [C] (figure 33) until it is sufficiently taut.

33

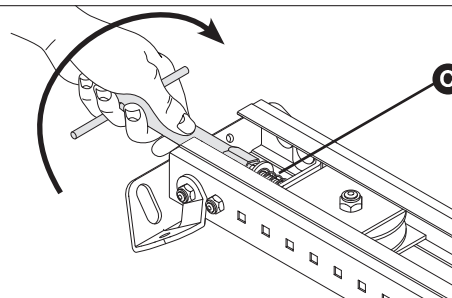

3.3.3 – Fixing of the gearmotor to the guide

1 Couple the GD102 gearmotor's shaft extension with the head of the guide [B]; then secure them using the four M6,3x45 screws [E].

34

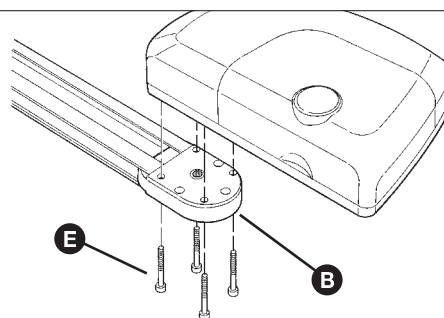

The gearmotor can be rotated in three different positions

35

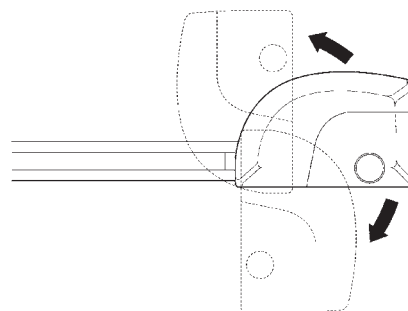

3.3.4 – Fixing of the gearmotor to the ceiling

1 Observing the A, B and C positions shown in Figure 8, mark the 2 fastening points for the guide's front bracket in the centre of the garage door (or slightly off-centre – Figure 11).

Depending on the type of material, the front bracket can be fastened using rivets, anchors or screws (Figure 36). If positions A, B, and C (figure 8) allow it, the bracket can be fastened directly to the ceiling.

36

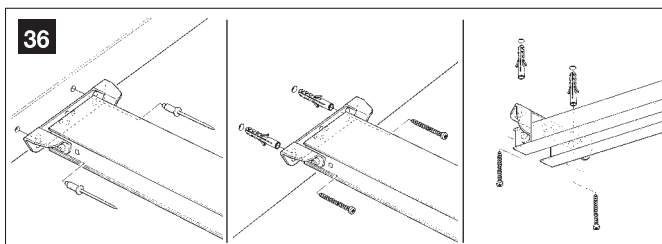

2 After drilling the holes, leave the head of the gearmotor on the ground, lift the guide from the front and secure it with two screws, anchors or rivets depending on the type of surface.

3 Secure the mounting brackets **[F]** using the screws **[G]**, and nuts **[H]** and choosing the hole that is closest to the established position B (see Figure 8).

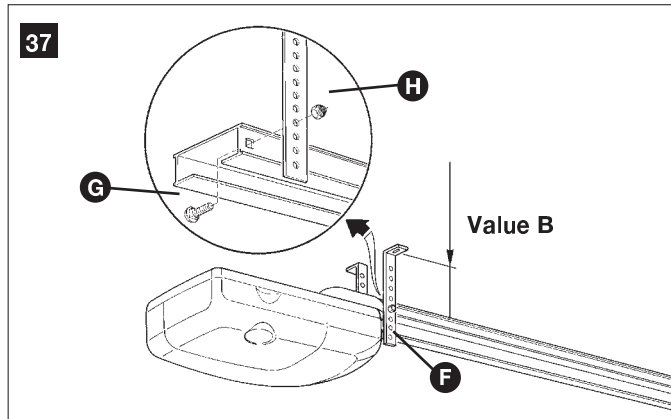

4 Using a ladder, lift the gearmotor and position the brackets against the ceiling. Mark the drilling points, then put the gearmotor back on the ground.

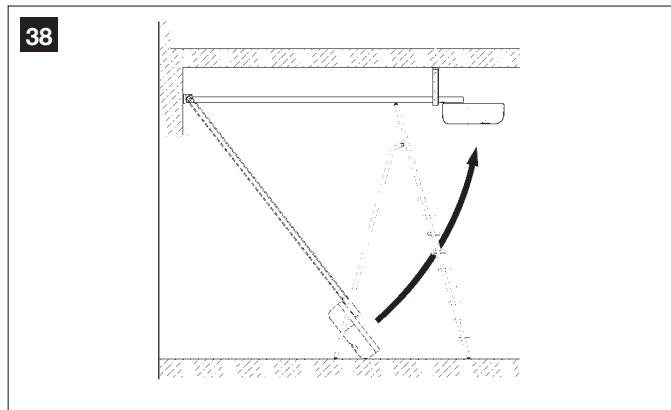

5 Drill the holes as marked; then, using a ladder, lift the gearmotor, position the brackets over the holes you have just drilled and fasten them using screws and anchors suited to the material.

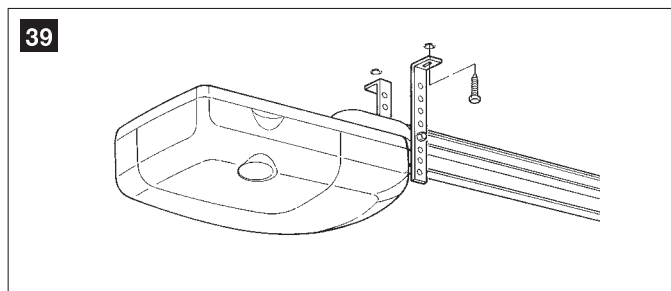

6 Make sure that the guide is perfectly horizontal, then cut the excess of the brackets using a hacksaw.

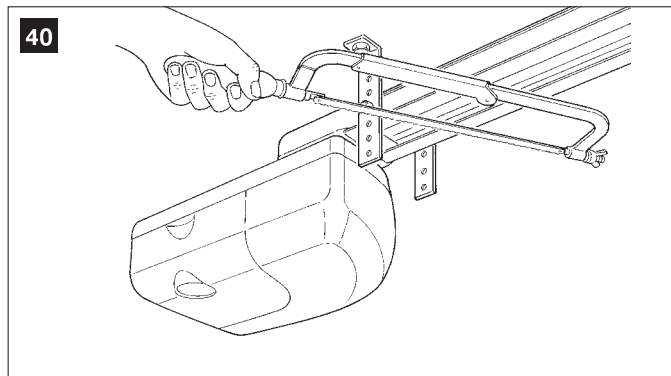

7 With the door closed, pull the cord and release the carriage **[I]** from the guide.

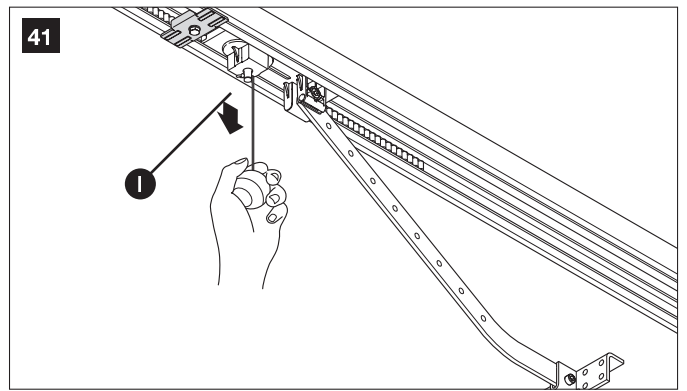

8 Slide the carriage until the door mounted bracket **[L]** shown in Figure 42 is positioned on the upper edge of the door, exactly perpendicular to the guide **[M]**.

Next, secure the door mounted bracket **[L]** with screws or rivets. Use screws or rivets that are suitable for the door material, making sure that they are capable of bearing all the strain resulting from opening and closing the door.

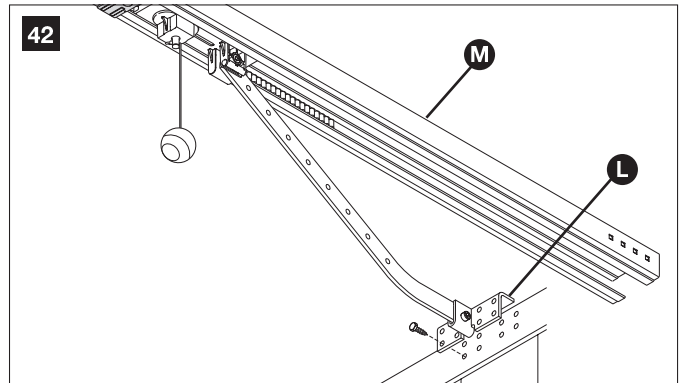

9 Loosen the screws in the two mechanical stops, then place the front mechanical stop **[N]** before the carriage (Figure 43).

Push the carriage hard in the closing direction and, in the reached position, tighten the screw firmly **[O]**.

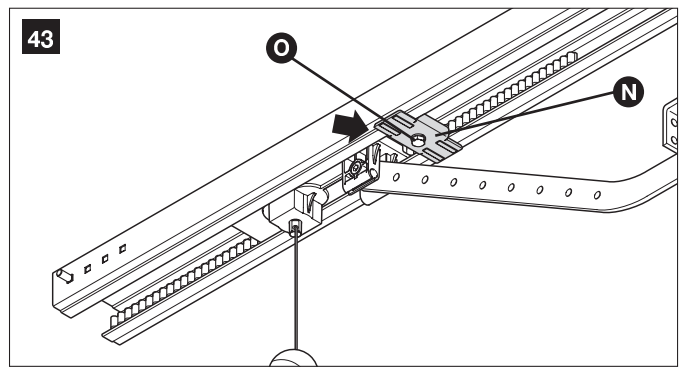

10 Open the door manually to the desired open position, then place the rear mechanical stop **[P]** near the carriage (Figure 44) and secure it by tightening the screw firmly **[O]**.

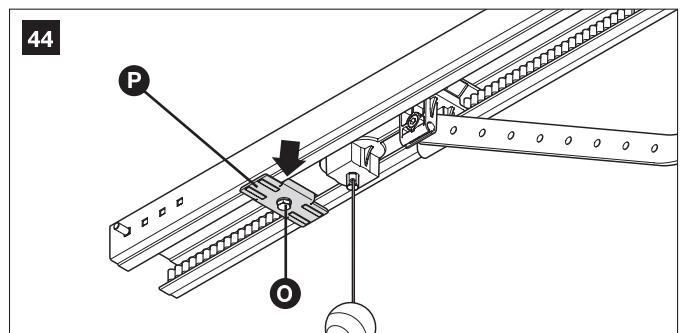

11 Make sure that the release cord can be activated at a height less than 1,8 m.

3.3.5 – PH200 photocells (optional)

Caution: disconnect the power supply to the system before performing any installation operations.

⚠ • position each photocell 40/60 cm above the ground • position them on the opposite sides of the zone to be protected • position them as close as possible to the door (maximum distance = 15 cm) • a tube for passing the cables must be present in the fastening point • orient the TX transmitter towards the central zone of the RX receiver (allowed misalignment: maximum 5°)

01. Remove the front glass (Phase 01 - Fig. 45)

02. Remove the upper casing then the internal casing of the photocell (Phase 02 - Fig. 45)

03. Perforate the lower casing in the point where the cables should pass (Phase 03 - Fig. 45)

04. - Position the lower casing in the point where the tube for the passage of the cables arrives and mark the perforation points (Phase 04 - Fig. 45)

- Use a percussion drill to drill the wall with a 5 mm bit. Insert the 5 mm wall plugs (Phase 04 - Fig. 45)

- Pass the electrical cables through the relevant holes and fasten the lower casing with the screws (Phase 04 - Fig. 45)

05. - Connect the electrical cable to the terminals of the TX and RX, which must be connected in parallel to each other then connected to the terminal on the control unit (Fig. 65). It is not necessary to observe any polarity.

- Put back in place, in the following order, the inner casing followed by the upper casing to be fastened with the two screws then, lastly, insert the cover and exert slight pressure to close it (Phase 05 - Fig. 45).

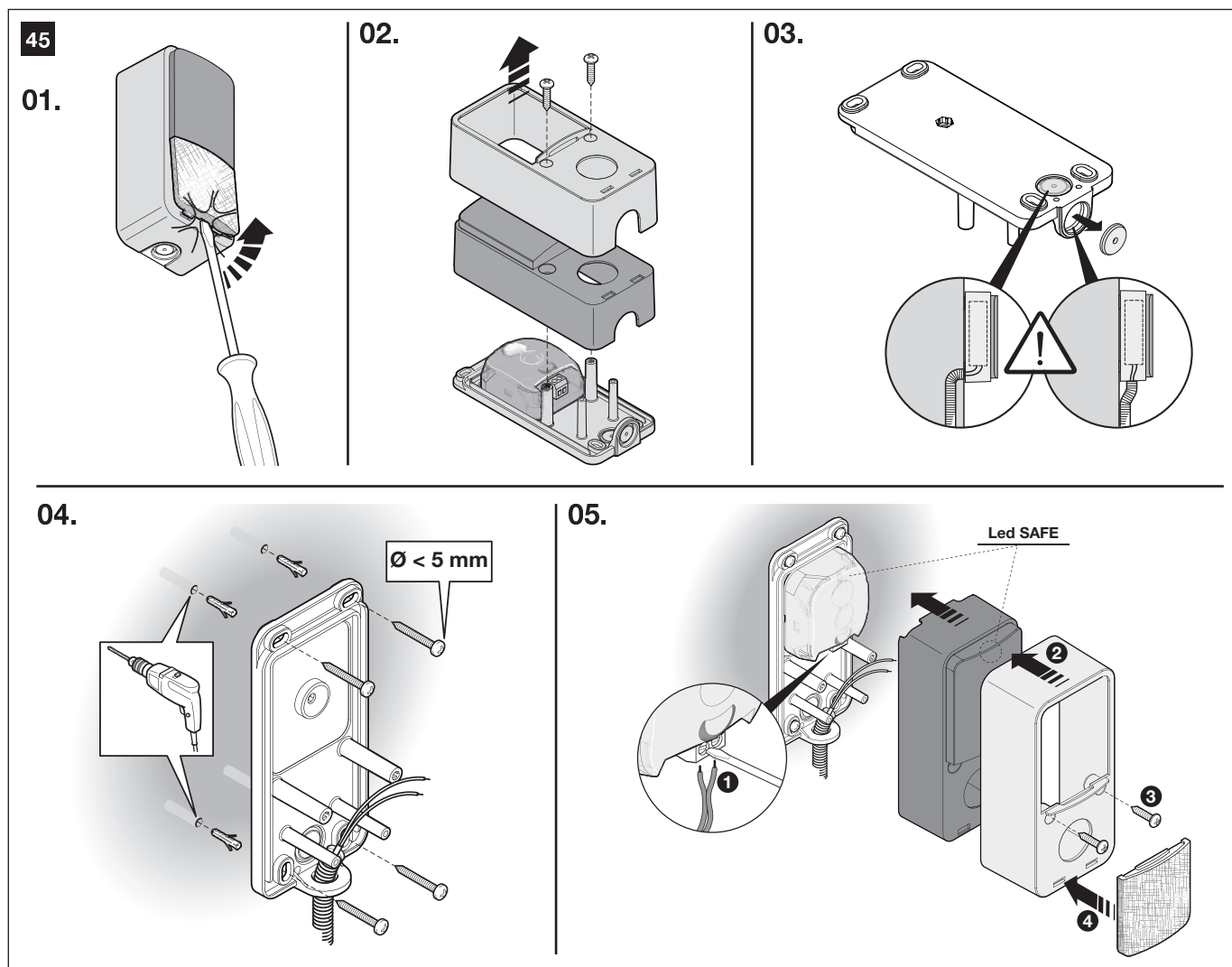

3.3.6 – FL200 flashing light (optional)

▲ The flashing light must be positioned near the door in a clearly visible position. It can be fastened to a horizontal or vertical surface.

• For connection to the Flash terminal, no polarity needs to be observed; instead for connection of the shielded aerial cable, it is necessary to connect the cable and sheath as shown in Fig. 46(06) and Fig. 65.

Choose the most suitable position in which to install the flashing light: it must be positioned near the door in a clearly visible position. It can be fastened to a horizontal or vertical surface.

For the installation procedure see Fig. 46.

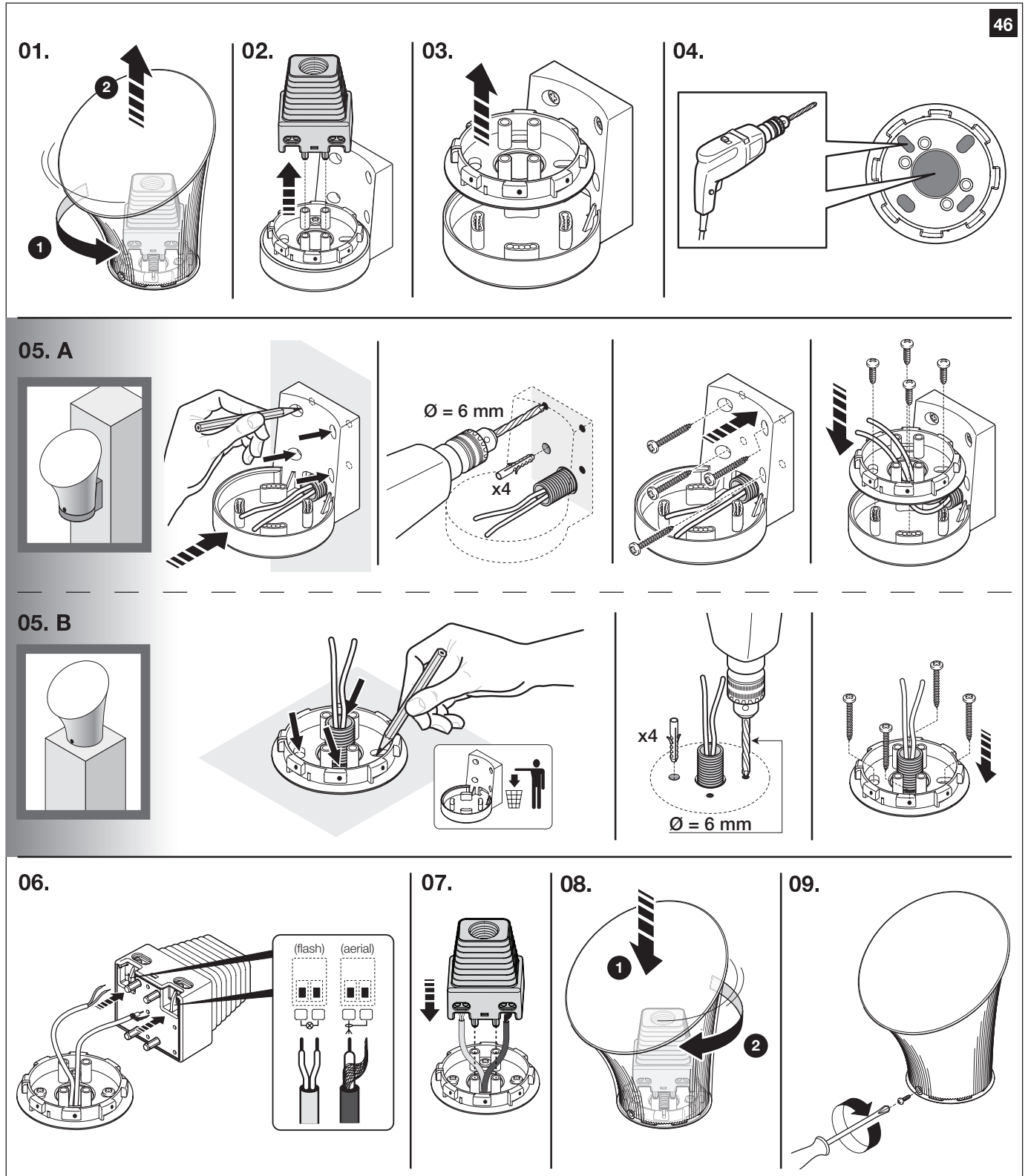

3.3.7 – Electrical connections to the control unit

1 Unscrew screw [A] and push button [B], to open the lid.

2 Thread the cables through the slit [C].

3 Refer to figure 65 for the electrical extra low voltage connection of the various devices to the control unit terminals.

- The terminals have the same colour coding as the corresponding devices; for example, the grey terminal (SbS) of the control unit must be connected to the grey terminal (SbS) of the accessory.

- For most connections you do not need to observe any polarity; only for the shielded cable of the aerial incorporated in the FL200 flashing light (optional accessory) it is necessary to connect the central core and the shield as shown in figure 65.

- If you are using the flasher's aerial, remove the piece of wire (connected to the green terminal at the factory) and connect the RG58-type shielded braiding.

- The terminals [D] can be removed in order to facilitate the operations as shown in figure 66; make the connections and then reinsert them.

4 When the connections have been completed, secure the cables using suitable clamps.

5 To close the cover, turn and push until a click is heard. Secure the screw [A].

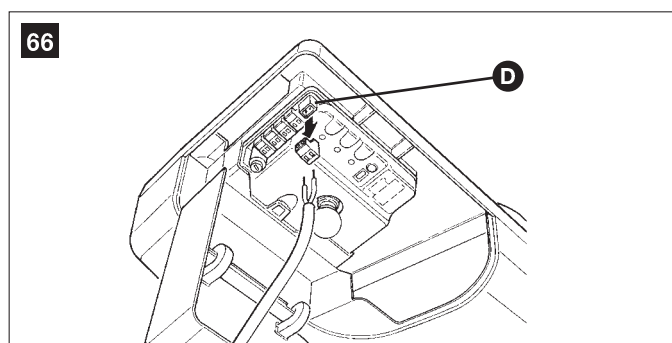
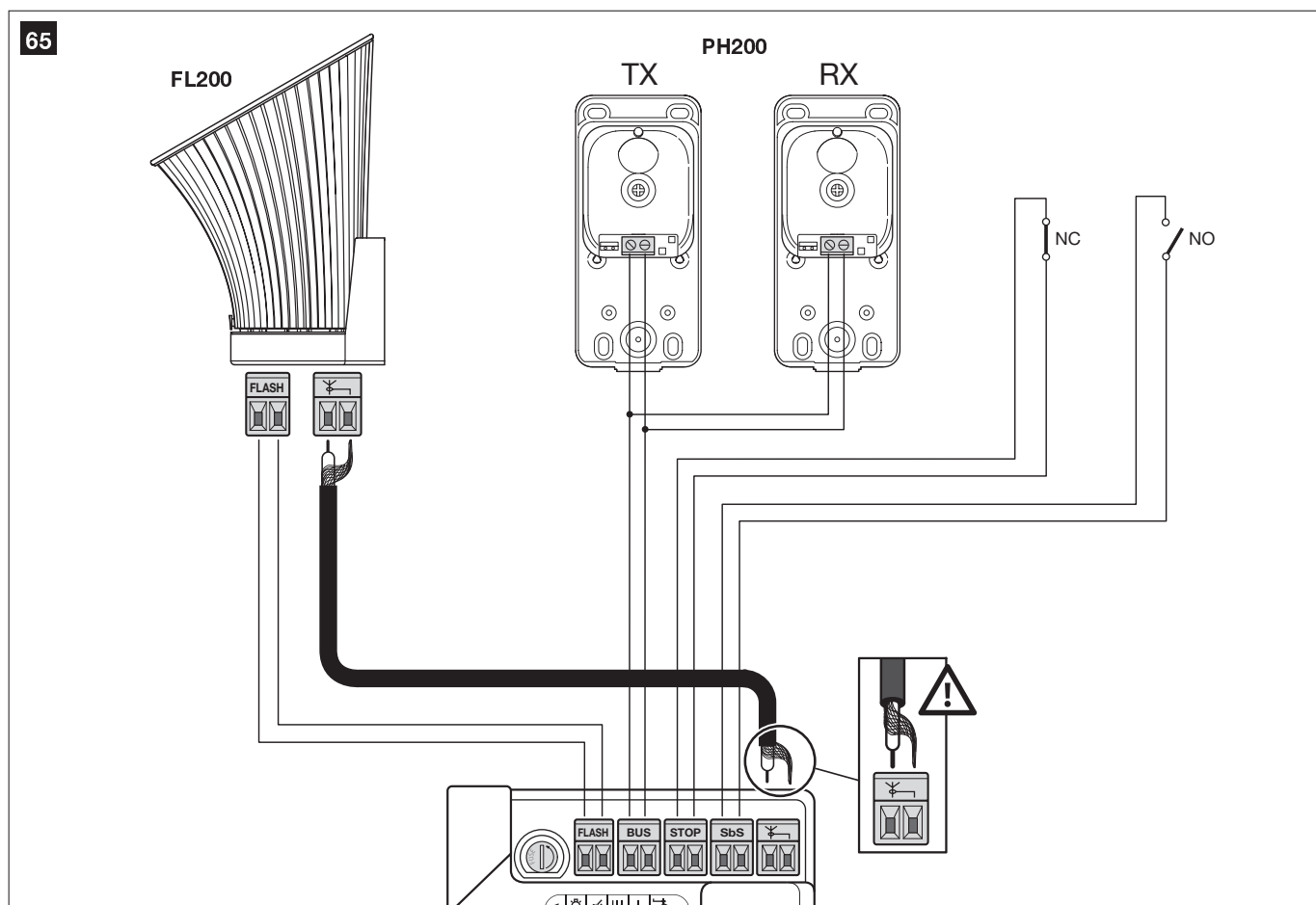
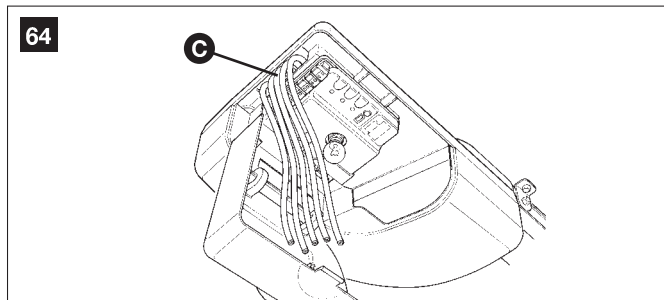
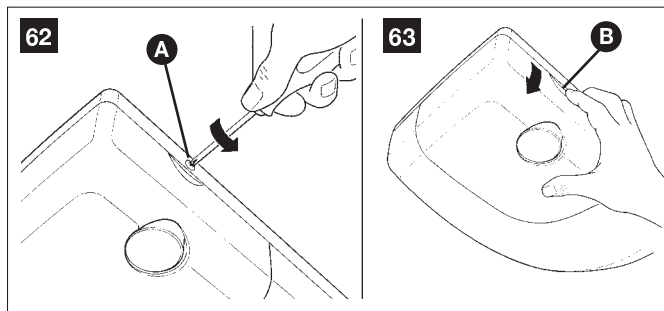

3.4 – POWER SUPPLY CONNECTION

⚠ The connection of AVIO to the mains must be made by a qualified electrician.

To carry out tests, insert the plug for AVIO in a power outlet; if necessary, use an extension cord.

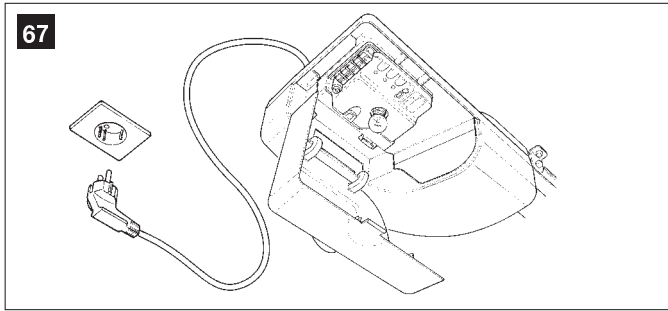

3.5 – INITIAL CHECKS

As soon as the control unit is energised, you should check the following:

1 Make sure that the LED **[A]** flashes regularly, with about one flash per second.

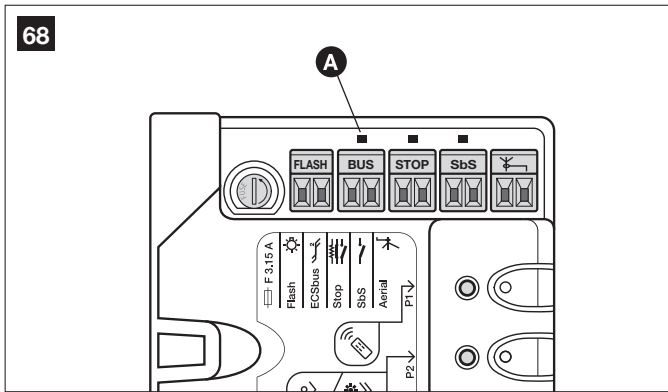

2 If the system is equipped with the PH200 photocells, make sure that the SAFE LED **[B]** shown in figure 69 flashes (on both TX and RX). The type of flashing is irrelevant, it depends on other factors; what matters is that it is not always off or always on.

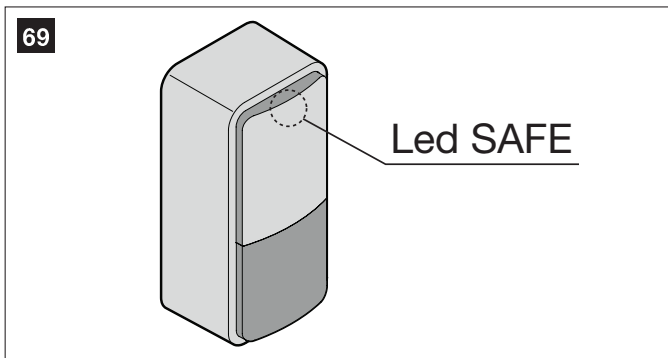

4 If the above conditions are not satisfied, you should immediately switch off the power supply to the control unit and check the cable connections more carefully. For more useful information see also chapters 5.5 "Troubleshooting" and 5.6 "Diagnostics and Signals".

3.5.1 – Recognition of the connected devices

When you have completed the initial checks, the control unit must recognise the devices connected to it on the "BUS" and "STOP" terminals.

1 On the control unit, press the P2 button **[C]** and hold it down for at least three seconds, then release the button (Figure 71).

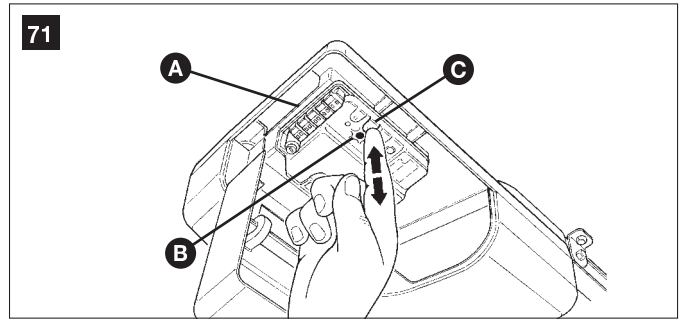

2 Wait a few seconds for the control unit to finish recognising the devices.

3 When the recognition procedure is completed, the STOP LED **[A]** must remain on, while the P2 LED **[B]** must go off. If the P2 LED flashes it means that an error has occurred: see paragraph 5.5 "Troubleshooting".

The connected devices recognition stage can be repeated again at any time, even after the installation (for example, if an additional photocell is installed); just repeat the procedure starting from step 1.

3.5.2 – Recognition of the door's open and closed positions

After recognising the devices, the control unit must recognise the door's open and closed positions. During this stage, the stroke of the door from the closing stop to the opening stop is detected.

1 Make sure that the carriage is attached.

2 Press key P3 **[A]** on the control unit and hold it down for at least three seconds, then release the key (Figure 72).

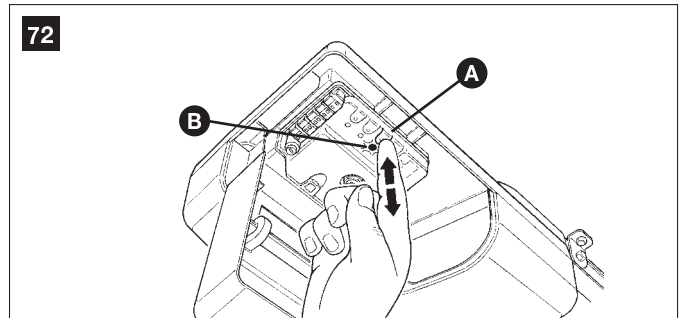

- Wait until the control unit has completed the recognition stage: closing, opening and re-closing of the door.

- If any device is triggered during the recognition stage, or the P3 key is pressed, the recognition stage will be immediately interrupted. In this case it must be repeated from the beginning.

- During the recognition stage the courtesy light will flash just like the flashing light.

3 If the P3 LED **[B]** flashes at the end of the learning stage, it means that there is an error; see paragraph 5.5 "Troubleshooting".

4 Press the yellow button **[C]** in figure 73 to execute a complete opening and closing manoeuvre. Then push it again to perform a complete closing manoeuvre. During these two manoeuvres the control unit memorises the force needed at each point along the stroke.

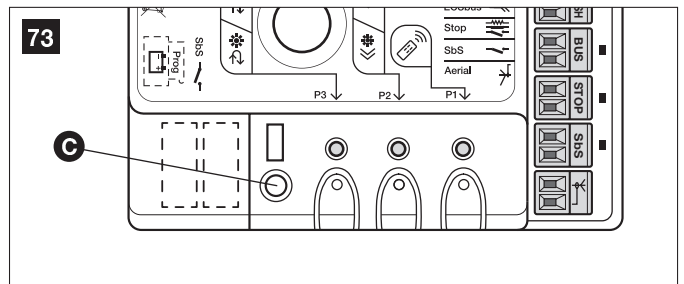

It is important that these two first manoeuvres are not interrupted by any commands.

If the manoeuvres are not completed, repeat the recognition procedure starting from step 1.

The position recognition stage can be repeated at any time in the future (for instance, if one of the mechanical stops is moved); just repeat starting from step 1.

⚠ WARNING: if the belt is not tightened properly, during the search for the positions it may slip between the belt and the pinion. If this happens, stop the learning procedure by pressing key P3 and stretch the belt by tightening the nut [D]. Then repeat the recognition procedure starting from step 1.

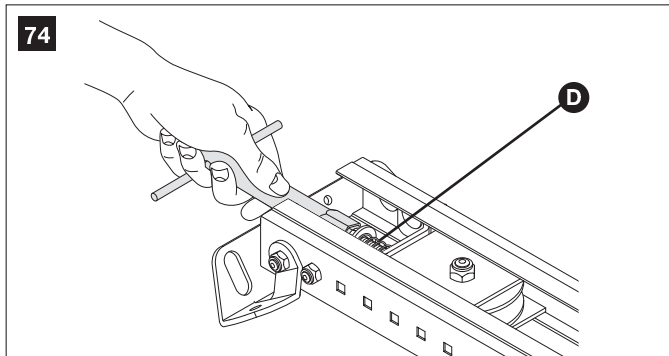

3.5.3 – Testing the radio transmitter

To test the transmitter just press one of its 4 keys, make sure that the red LED [A] flashes and that the automation carries out the related command. The command associated to each button depends on how it has been memorised (see paragraph 5.4 “Memorisation of radio transmitters”).

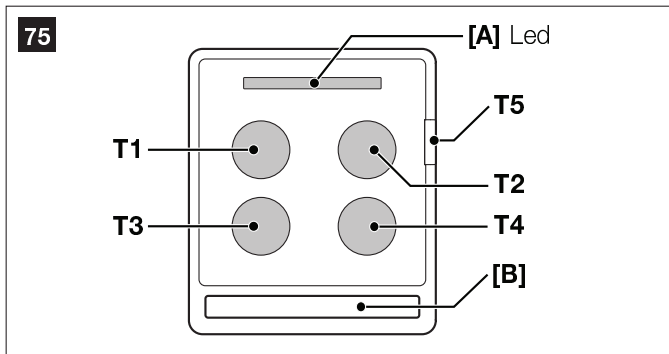

3.6 – ADJUSTMENTS

3.6.1 – Selecting door speed

The door can be opened and closed at two speeds: “slow” or “fast”.

To switch from one speed to the other press the P2 button [A] momentarily; the corresponding P2 LED [B] will light up or go off; if the LED is off the speed is “slow”, if the LED is on the speed is “fast”.

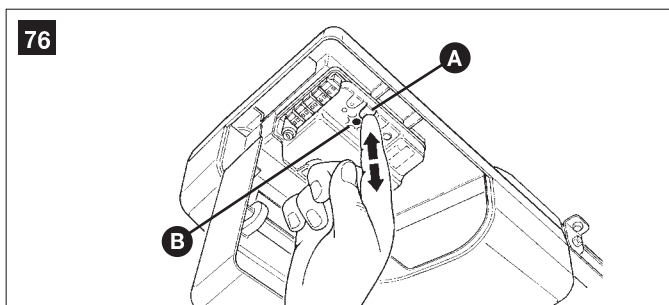

3.6.2 – Selecting the type of operating cycle

The opening and closing of the door can take place according to different operating cycles:

- single cycle (semiautomatic): the door opens with a command and stays open until the next command is given, causing it to close.
- complete cycle (automatic closing): the door opens with a command and then closes automatically after a short time (for the time, see paragraph 5.1.1 “Adjusting the parameters with the radio transmitter”).

To switch from one operating cycle to the other, press the P3 button [A] momentarily; the corresponding LED P3 [B] will light up or go off; if the LED is off the cycle is “single”, if the LED is on the cycle is “complete”.

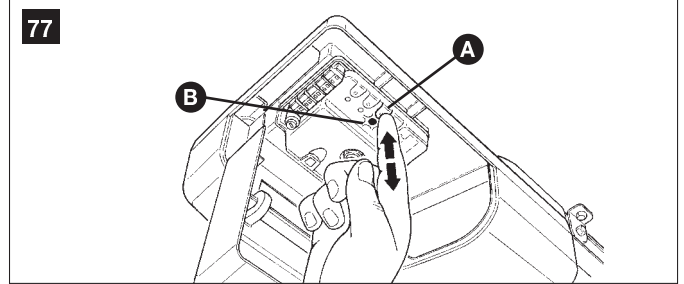

3.7 – TESTING AND COMMISSIONING

These are the most important operations, designed to guarantee the maximum safety and reliability of the automation system.

The testing procedure can also be used as a periodic check of the devices that make up the automation.

⚠ The testing and commissioning operations must be performed by qualified and experienced personnel who must establish what tests should be conducted based on the risks involved and verify the compliance of the system with applicable regulations, legislation and standards, in particular with all the provisions of EN standards 12445 and 12453 which establish the test methods for sectional and overhead door automation systems.

3.7.1 – Testing

⚠ 1 Make sure that the provisions contained in chapter 1 “WARNINGS” have been carefully observed.

2 Using the radio transmitter, test the opening and closing of the door and make sure that the door moves in the intended direction.

The test should be carried out a number of times to make sure that the door moves smoothly, that there are no points of excessive friction and that there are no defects in the assembly or adjustments.

3 Check the proper operation of all the safety devices, one by one (photo-cells, sensitive edges, etc.). In particular, each time a device is activated, the “BUS” LED on the control unit flashes for a longer time, confirming that the control unit recognises the event.

4 To check the photocells (if provided), pass a 5 cm diameter, 30 cm long cylinder on the optical axis, first near TX, then near RX and finally at the mid-point between them and make sure that in all these cases the device is triggered, switching from the active to the alarm status and vice-versa; finally, that it causes the intended action in the control unit, for example: that it causes the reversal of the movement during the closing manoeuvre.

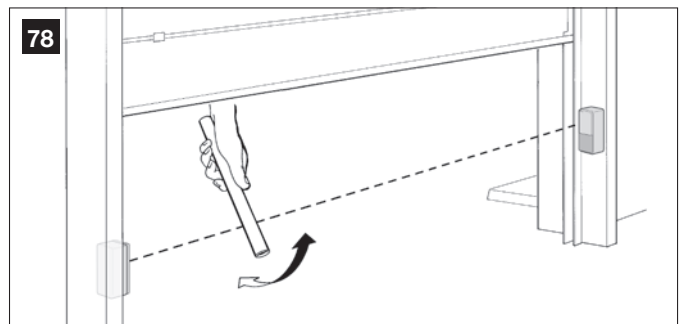

5 The control of the correct obstacle detection is performed with the 700x300x200mm test parallelepiped with 3 black sides and 3 polished white or mirrored sides, according to the EN 12445 standard.

6 Measure the impact force according to EN standards 12445 and 12453. If “motor force” control is used to assist the system for the reduction of the impact force, try to find the adjustment that gives the best results.

7 Ensure that the entire mechanism is correctly adjusted and that the automation system inverts the manoeuvre when the door collides with a 50 mm high object on the floor.

8 Ensure that the automation prevents or blocks the opening manoeuvre when the door is loaded with a mass of 20 kg, fixed in the middle of the door’s lower edge.

3.7.2 – Commissioning

The commissioning operations can be performed only after all the tests have been successfully carried out. Partial commissioning or implementation of “temporary” conditions are not permitted.

1 Prepare the technical documentation for the automation, which must include at least: assembly drawing (e.g. figure 1), wiring diagram (e.g. figure 65), analysis of hazards and solutions adopted, manufacturer’s declaration of conformity of all the devices installed. For AVIO use Annex 1 “CE Declaration of Conformity of the AVIO components”.

2 Post a label on the door providing at least the following data: type of automation, name and address of manufacturer (person responsible for the “commissioning”), serial number, year of manufacture and “CE” marking.

3 Fill out the declaration of conformity and deliver it to the owner of the automation system; for this purpose you can use Annex 2 “CE Declaration of Conformity”.

4 Prepare the operating guide and deliver it to the owner of the automation system; Annex 3 “OPERATING GUIDE” can be used as an example.

5 Prepare the maintenance schedule and deliver it to the owner of the automation system; it must provide directions regarding the maintenance of all the automation devices.

6 Post a permanent label or sign detailing the operations for the release and manual manoeuvre (use the figures in Annex 3 “Operating guide”).

7 Before commissioning the automation system, inform the owner regarding dangers and hazards that are still existing.

8 Post a permanent label or sign with this image on the door (minimum height 60 mm) with inscription WARNING – RISK OF CRUSHING.

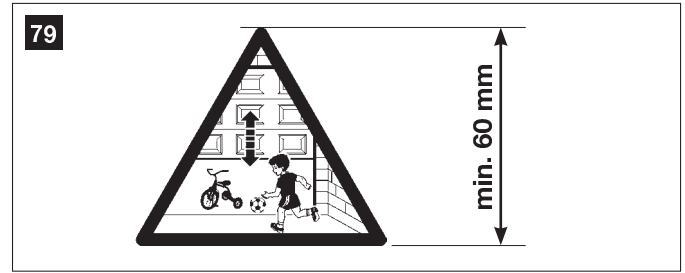

MAINTENANCE

— STEP 4 —

⚠ The maintenance operations must be performed in strict compliance with the safety directions provided in this manual and according to the applicable legislation and standards.

The devices used for the AVIO automation system do not require any special maintenance. However, periodically make sure (at least once every six

months) that all the devices are perfectly efficient.

To this end, carry out all the tests and checks described in paragraph 3.7.1 “Testing” and the operations described in paragraph 7.3.3 “Maintenance operations to be performed by the user”.

If other devices are present, follow the directions provided in the corresponding maintenance schedule.

PRODUCT DISPOSAL

This product is an integral part of the automation system it controls and must be disposed of along with it.

As in installation operations, at the end of the product’s lifespan, disposal operations must be performed by qualified personnel.

The product is made of various types of materials: some of them may be recycled, while others must be scrapped. Seek information on the recycling and disposal methods envisaged by the local regulations in your area for this product category.

Warning! – Some parts of the product may contain polluting or hazardous substances which, if released to the environment, may cause serious damage to the environment or to human health.

As indicated by the symbol alongside, disposal of this product with household waste is prohibited. Separate the waste into categories for disposal,

according to the methods established by current legislation in your area, or return the product to the retailer when purchasing a new version.

Warning! – Local legislation may impose heavy fines in the event of illegal disposal of this product.



Disposal of buffer battery (if present)

Warning! – Even if discharged, the batteries may contain pollutant substances and therefore must never be disposed of in normal waste collection points.

Dispose of according to separate waste collection methods as envisaged by current local standards.

— STEP 5 —

The following chapters describe different ways of customising AVIO to make it suitable for specific application requirements.

5.1 – ADVANCED ADJUSTMENTS

5.1.1 – Adjusting the parameters with the radio transmitter

The radio transmitter can be used to adjust certain control unit operation parameters: there are four parameters and each of them can have four different values:

- 1) Pause time: time during which the door remains open (in the automatic closing mode).
- 2) Partial opening: partial door opening mode.
- 3) Motor force: maximum force beyond which the control unit recognises an obstacle and reverses the movement.
- 4) “Step-by-Step” function: sequence of movements associated to each “Step-by-Step” command.

The parameter adjustment operation can be performed using a radio transmitter, provided it is memorised in mode 1.

If no transmitter memorised in Mode 1 is available, you can memorise one just for this phase and delete it immediately afterwards (see paragraph 5.4.1 “Memorisation Mode 1” and paragraph 5.4.4 “Deleting a radio transmitter”).

WARNING: when using the transmitter to make adjustments you need to give the control unit time to recognise the radio command; this means that the buttons must be pressed and released slowly, held down for at least one second, then released for one second and so on.

- 1 Press buttons T1 and T2 on the radio transmitter simultaneously for at least 5s.
- 2 Release the two buttons.

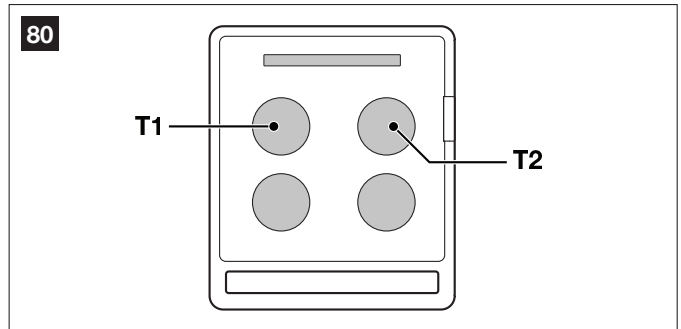

3 Within 3 seconds, perform the action described in Table 9 based on the parameter to be modified

Example: to set the pause time at 40 s.

- 1st Press buttons T1 and T2 and hold them down for at least 5s
- 2nd Release T1 and T2
- 3rd Press button T1 three times

All the parameters can be adjusted as required without any contraindication; only the adjustment of the “motor force” requires special care:

- Do not use high force values to compensate for points of abnormal friction on the door. Excessive force can compromise the operation of the safety system or damage the door.
- If the “motor force” control is used to assist the impact force reduction system, measure the force again after each adjustment in compliance with EN standard 12445.
- The weather conditions may affect the movement of the door, therefore periodic re-adjustments may be necessary.

TABLE 9

Parameters	N°	Setting	Action: operation to be performed at point 3 in the adjustment phase
Pause Time	1°	10s	Press button T1 once
	2°	20s (*)	Press button T1 twice
	3°	40s	Press button T1 three times
	4°	80s	Press button T1 four times
Partial opening	1°	Opening the door 1/4 of the way	Press button T2 once
	2°	Opening the door half way (*)	Press button T2 twice
	3°	Opening the door 3/4 of the way	Press button T2 three times
	4°	Opening the door all the way	Press button T2 four times
Motor force	1°	Low	Press button T3 once
	2°	Medium-low (*)	Press button T3 twice
	3°	Medium-high	Press button T3 three times
	4°	High	Press button T3 four times
“Step-by-Step” function	1°	“Open”-“Stop”-“Close”-“Stop”	Press button T4 once
	2°	“Open”-“Stop”-“Close”-“Open” (*)	Press button T4 twice
	3°	“Open”-“Close”-“Open”-“Close”	Press button T4 three times
	4°	“Open”-“Open”-“Open” (opening only)	Press button T4 four times

(*) Original factory setting

5.1.2 – Checking the parameters with the radio transmitter

With a radio transmitter memorised in Mode 1 you can check the values set for each parameter at any time by following the sequence described below:

- 1 Press buttons T1 and T2 on the radio transmitter simultaneously for at least 5s.
- 2 Release the two buttons.
- 3 Within 3 seconds, perform the action described in Table 10 based

on the parameter to be checked.

4 Release the button when the flashing light starts flashing.

5 Count the flashes and, based on their number, check the corresponding value in Table 10.

Example: If the flashing light flashes three times after you have pressed T1 and T2 for 5s and then button T1, the pause time is set at 40s.

TABLE 10

Parameter	Action
Pause Time	Press button T1 and hold it down
Partial opening	Press button T2 and hold it down
Motor force	Press button T3 and hold it down
“Step-by-Step” function	Press button T4 and hold it down

5.2 – OPTIONAL ACCESSORIES

In addition to the devices featured in AVIO, other ones are available as optional accessories designed to enhance the automation system and improve its safety and performance.

PR100: (For AVIO1000 only) 24V buffer battery for power supply in the event of power failure. It guarantees at last 10 complete cycles.

GA2: OSCILLATING ARM accessory that enables the system to open overhead-type doors

GU2: MANUAL RELEASE KIT accessory that enables the manual opening of the door even in the event of power failures.

For information on the new accessories, refer to the Nice Home catalogue or visit the website www.niceforyou.com.

5.3 – ADDING OR REMOVING DEVICES

Devices can be added to or removed from the AVIO automation system at any time.

⚠ Do not add any devices until you have made sure that they are perfectly compatible with AVIO; for further information contact Nice Customer Service.

5.3.1 – ECSBus

ECSBus system allows device connections to be made using just 2 ECS-Bus conductors for both the electricity supply and the communication signals. All the devices are connected in parallel on the 2 wires of the BUS itself; each device is individually recognised because a univocal address is assigned to it during the installation.

The photocells, as well as other devices that adopt this system, can be connected to BUS, such as safety devices, control buttons, signalling lights etc.

For information on the ECSBus devices, refer to the Nice Home catalogue or visit the site www.niceforyou.com.

The control unit recognises all the connected devices individually through a suitable recognition process, and can detect all the possible abnormalities with absolute precision. For this reason, each time a device connected to BUS is added or removed the control unit must go through the recognition process; see paragraph 5.3.3 “Recognition of Other Devices”.

5.3.2 – STOP input

STOP is the input that causes the immediate interruption of the manoeuvre (with a short reverse run). Devices with output featuring normally open “NO” contacts and devices with normally closed “NC” contacts, as well as devices with 8,2kΩ constant resistance output, like sensitive edges, can be connected to this input. Multiple devices, even of different type, can be connected to the STOP input if suitable arrangements are made. To do this, proceed as described in the following table 11:

Note 1. The NO and NC combination can be obtained by placing the two contacts in parallel, and placing in series to the NC contact an 8,2kΩ resistance (therefore, the combination of 3 devices is also possible: NO, NC and 8,2kΩ).

Note 2. Any number of NO devices can be connected to each other in parallel.

Note 3. Any number of NC devices can be connected to each other in series.

TABLE 11

		1 st device type:		
		NO	NC	8,2kΩ
2 nd device type:	NO	In parallel (note 2)	(note 1)	In parallel
	NC	(note 1)	In series (note 3)	In series
	8,2kΩ	In parallel	In series	(note 4)

Note 4. Only two devices with 8,2kΩ constant resistance output can be connected in parallel; if needed, multiple devices must be connected “in cascade” with a single 8,2kΩ termination resistance.

Warning: if the STOP input is used to connect devices with safety functions, only the devices with 8,2kΩ constant resistance output guarantee the fail-safe category 3.

During the recognition stage the control unit, like BUS, recognises the type of device connected to the STOP input; subsequently it commands a STOP whenever a change occurs in the recognised status.

5.3.3 – Recognition of Other Devices

Normally the recognition of the devices connected to the BUS and the STOP input takes place during the installation stage. However, if new devices are added or old ones removed, the recognition process can be gone through again by proceeding as follows:

1 On the control unit, press the P2 **[A]** button and hold it down for at least five seconds, then release it.

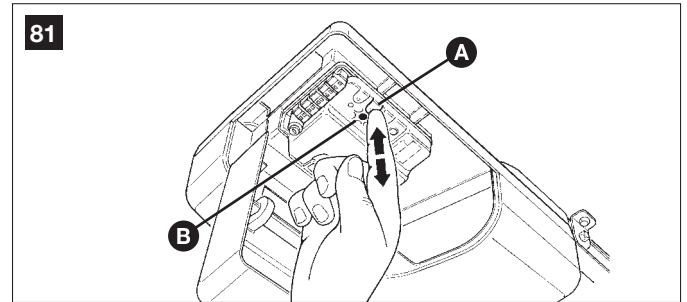

2 Wait a few seconds for the control unit to finish recognising the devices.

3 When the recognition stage is completed the P2 LED **[B]** should go off. If the P2 LED flashes it means that an error has occurred: see paragraph 5.5 “Troubleshooting”.

4 After you have added or removed any devices, the automation system must be tested again according to the directions contained in paragraph 3.7.1 “Testing”.

5.3.4 – Photocells addition

You can install a pair of photocells (not supplied with AVIO) at any time.

To ensure the correct recognition of the photocells by the control unit, the former must be assigned addresses by means of jumpers. The routing operation is performed both on TX as well as RX (arranging the jumpers in the same manner). Make sure there are no other photocell pairs with the same address.

The photocells need to be assigned addresses to make sure that they are correctly recognised among the other BUS devices, and in order to assign the performed function.

The photocell of a sectional door automation system can be installed following that shown in fig. 82. Refer to Fig. 83 for overhead door automation systems.

Photo E and **Photo F** are used in installations that require the complete protection of the automation system, also in opening.

The recognition phase must be performed after installation or the removal of photocells as described in paragraph “5.3.3 Recognition of Other Devices”.

5.4 – MEMORISATION OF RADIO TRANSMITTERS

The control unit incorporates a radio receiver for ECCO5 transmitters (various models). The transmitters supplied are not memorised, therefore it is first necessary to memorise the 1st transmitter (Mode 1).

If you wish to memorise a new radio transmitter you have two choices:

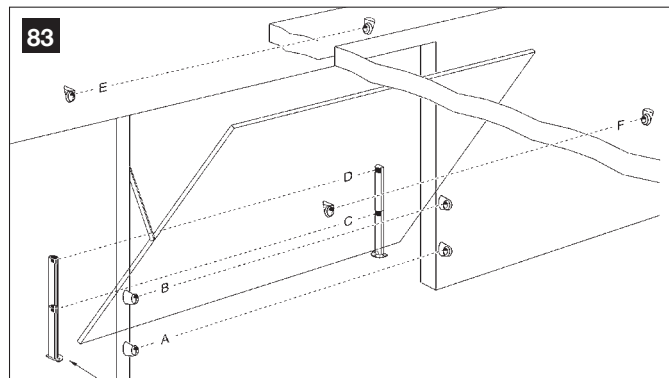
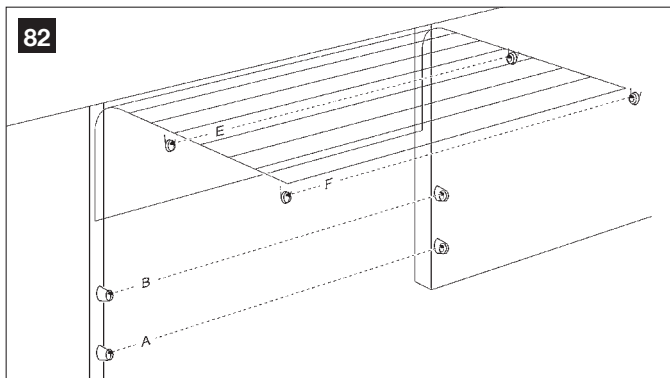

TABLE 12

Photocell	Jumpers	Photocell	Jumpers
A Internal photocell h= 50 cm; activated when closing		E External photocell activated when opening	
B Internal photocell h= 100 cm; activated when closing		F Internal photocell activated when opening	
C External photocell h= 50 cm; activated when closing and opening		G INADMISSIBLE CONFIGURATION	
D External photocell h= 100 cm; activated when closing and opening			

⚠ WARNING: in the AVIO600 version the BUS output has a maximum load of 1 unit (with A type addresses only).
in the AVIO1000 version it has a maximum load of 6 units; a pair of photocells absorbs power equal to 1 ECSBUS unit.

• **Mode 1:** in this “mode” the radio transmitter is used to its fullest extent, i.e. all the buttons execute a pre-established command. It is obvious that in Mode 1 a radio transmitter can be used to command a single automation, i.e.:

Button T1	“Step-by-Step” command
Button T2	“Open partially” command
Button T3	“Open only” command
Button T4	“Close only” command

• **Mode 2:** one of the four commands available can be associated to each button. This mode, used properly, allows you to command 2 or more different automations; for example:

Button T1	“Open only” command automation N° 1
Button T2	“Close only” command automation N° 1
Button T3	“Step-by-Step” command automation N° 2
Button T4	“Step-by-Step” command automation N° 3

Obviously, each transmitter is a separate unit, and while some are memorised in mode 1 others can be memorised in mode 2 on the control unit.

The overall memory capacity is 150 units; memorisation in mode 1 takes up one unit for each transmitter while mode 2 takes up one unit for each button.

Warning: since the memorisation procedures are timed (10s), you must read the instructions in the following paragraphs before you proceed with their execution.

5.4.1 – Memorisation mode 1

1 Press button P1 **[A]** for at least 3s.

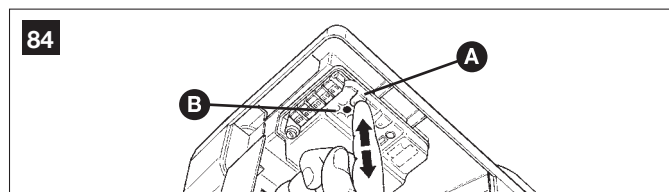

When the P1 LED **[B]** illuminates, release the button.

2 Within 10s, press any button on the radio transmitter to be memorised and hold it down for at least 3s.

If the memorisation procedure is successful, the “P1” LED will flash 3 times.

3 If there are other transmitters to be memorised, repeat step 2 within the next 10s, otherwise the memorisation stage will terminate automatically.

5.4.2 – Memorisation mode 2

With the memorisation in mode 2 of the radio transmitter, any one of the four commands (“Step-by-Step”, “Partial opening”, “Open only” and “Close only”) can be associated to each button.

In Mode 2 each button requires a separate memorisation stage.

1 Press button P1 **[A]** (figure 84) on the control unit as many times as the number corresponding to the desired command, according to the following table:

Once	“Step-by-Step” command
Twice	“Open partially” command”
3 times	“Open only” command
4 times	“Close only” command

- 2 Make sure that the P1 LED **[B]** makes as many quick flashes as the number corresponding to the selected command.
 - 3 Within 10 s, press the desired button on the radio transmitter to be memorised, and hold it down for at least 2 s.
- If the memorisation procedure is successful, the “P1” LED will flash 3 times slowly.
- 4 If there are other transmitters to be memorised for the same type of command, repeat step 3 within the next 10s, otherwise the memorisation stage will terminate automatically.

5.4.3 – Remote memorisation

A new radio transmitter can be memorised in the control unit without directly operating the buttons on it. You need to have an “OLD” pre-memorised operational radio transmitter. The “NEW” radio transmitter to be memorised will inherit the characteristics of the OLD one, i.e. if the OLD radio transmitter was memorised in Mode 1, the NEW one will also be memorised in Mode 1. In this case, during the memorisation stage you can press any key on the two transmitters. If, on the other hand, the OLD transmitter was memorised in Mode 2 you must press the button on the OLD transmitter which corresponds to the desired command, and the button on the NEW transmitter to which you wish to associate that command.

Holding the two transmitters, position yourself within the operating range of the automation and perform the following operations:

- 1 Press the button on the NEW radio transmitter and hold it down for at least 5s, then release it.
- 2 Press the button on the OLD radio transmitter 3 times slowly.
- 3 Press the button on the NEW radio transmitter once slowly.

At this point the NEW radio transmitter will be recognised by the control unit and will assume the characteristics of the OLD one.

If there are other transmitters to be memorised, repeat all the steps above for each new transmitter.

5.4.4 – Deleting a radio transmitter

Only if the system features a radio transmitter, you can delete it from the memory by proceeding as follows.

If the transmitter is memorised in Mode 1, only one deletion procedure will be needed and at step 3 you can press any button. If the transmitter is memorised in Mode 2, one deletion procedure will be needed for each key memorised.

- 1 Press the P1 button **[A]** (Figure 85) on the control unit and hold it down.

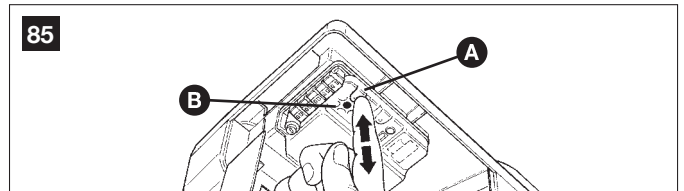

- 2 Wait until the P1 LED **[B]** lights up, then, within three seconds...
- 3 Press the key on the radio transmitter to be deleted and hold it down for at least three seconds. If the deletion procedure is successful, the P1 LED will flash rapidly five times. If the P1 LED flashes only once slowly, it means that the deletion procedure has not been successful because the transmitter is not memorised.
- 4 If there are other transmitters to be deleted, press the P1 key and repeat step 3 within ten seconds, otherwise the deletion procedure will be terminated automatically.

5.4.5 – Deleting all the radio transmitters

With this operation all the memorised transmitters are deleted.

- 1 Press the P1 button **[A]** on the control unit and hold it down (Figure 85).
- 2 Wait until the P1 LED **[B]** lights up, then wait until it goes off, then wait until it has flashed 3 times.
- 3 Release the P1 button precisely upon the third flash.
- 4 Wait approximately 4s for the deletion process to be completed; during this time the P1 LED will flash very quickly.

If the procedure is successful, after a few moments the P1 LED will flash slowly 5 times.

5.5 – TROUBLESHOOTING

The following table contains instructions to help you solve malfunctions or errors that may occur during the installation stage or in case of failure.

Symptoms	Probable cause and possible solution
The radio transmitter does not emit any signal (the LED [A] does not light up)	<ul style="list-style-type: none"> • Check to see if the batteries are exhausted, if necessary replace them (Paragraph 7.3.4 “Replacing the remote control battery”).
The manoeuvre does not start and the “BUS” LED [B] does not flash	<ul style="list-style-type: none"> • Make sure that the power cord is properly plugged into the mains outlet • Check to see if the fuses [E] or [F] are blown; if necessary, identify the reason for the failure and then replace the fuses with others having the same current rating and characteristics.
The manoeuvre does not start and the courtesy light [G] is off	<ul style="list-style-type: none"> • Make sure that the command is actually received. If the command reaches the SbS input, the corresponding “SbS” LED [D] must light up; if you are using the radio transmitter, the “BUS” LED must make two long flashes.
The manoeuvre does not start and the courtesy light flashes a few times	<ul style="list-style-type: none"> • Make sure that the STOP input is active, i.e. that the “STOP” LED [C] comes on. If this does not happen, check the device connected to the STOP input. • The photocell test which is performed at the start of each manoeuvre is not successful; check the photocells, also according to Table 12 (Paragraph 5.6.1 Photocells).
The manoeuvre starts but inverts immediately	<ul style="list-style-type: none"> • The selected force is too low to move the door. Check for possible obstacles and if necessary select a higher force as described in chapter 5.1 “Advanced adjustments”.
The manoeuvre is carried out but the flashing light does not work	<ul style="list-style-type: none"> • Make sure that there is voltage on the flashing light’s FLASH terminal during the manoeuvre (being intermittent, the voltage value is not important: approximately 10-30V~); if there is voltage, the problem is due to the lamp; in this case replace the lamp with one having the same characteristics.
The manoeuvre is carried out but the courtesy light does not work.	<ul style="list-style-type: none"> • Replace the lamp with one having the same characteristics.

86

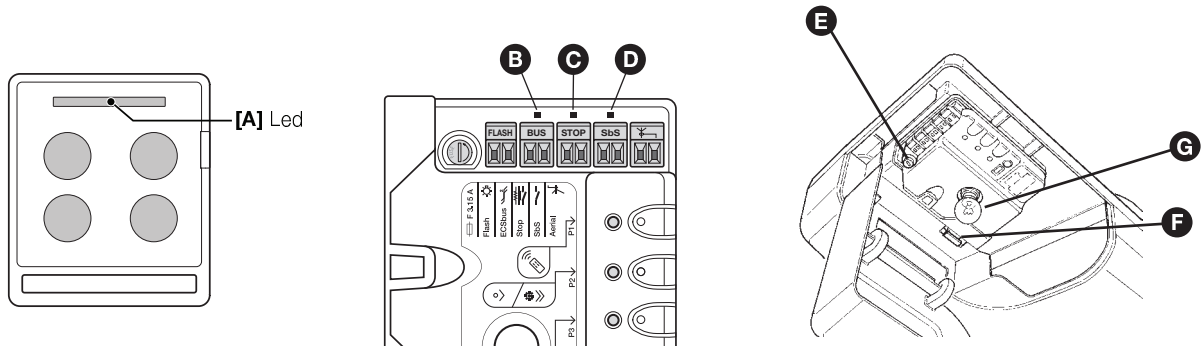

5.6 – DIAGNOSTICS AND SIGNALS

A few devices issue special signals that allow you to recognise the operating status or possible malfunctions.

5.6.1 – Photocells

The photocells are equipped with a “SAFE” LED (Figure 87) that allows you to check the operating status at any time.

87

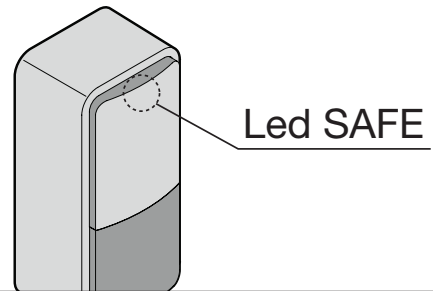

TABLE 14

LED “SAFE”	Status	Action
Off	The photocell is not powered or is faulty	Make sure that there is voltage (approx. 8-12 V $\overline{=}$) on the photocell's terminals; if the voltage is correct, the photocell is probably faulty
3 quick flashes and a second's pause	Device not recognised by the control unit	Repeat the recognition procedure on the control unit. Make sure that all the photocell pairs on BUS have correct addresses
1 very slow flash	The RX receives a perfect signal	Normal operation
1 slow flash	The RX receives a fair signal	Normal operation
1 quick flash	The RX receives a poor signal	Normal operation but you should check the TX-RX alignment and make sure the glasses are clean
1 very quick flash	The RX receives a very poor signal	It is at the limit of normal operation, you should check the TX-RX alignment and make sure the glasses are clean
Always on	The RX does not receive any signal	Check to see if there is an obstacle between TX and RX. Make sure that the LED on TX flashes once slowly. Check the TX-RX alignment

5.6.2 – Flashing and courtesy lights

During the manoeuvre the flashing light flashes once every second, while the courtesy light is always on; when something is wrong the flashes

are more frequent (half a second); the light flashes twice with a second's pause between flashes. The diagnostic flashing itself is signalled by the courtesy light.

TABLE 15

Quick flashes	Status	Action
1 flash 1 second pause 1 flash	ECSBus error	At the starting of the manoeuvre, the devices present do not correspond to those recognised; check and if necessary try repeating the recognition process. (5.3.3 “Recognition of Other Devices”). One or more devices may be faulty; check and, if necessary, replace them.
2 flashes 1 second pause 2 flashes	Photocell activated	At the start of the manoeuvre, one or more photocells do not enable it; check to see if there are any obstacles. If there is an obstacle impeding the movement no action is required.
3 flashes 1 second pause 3 flashes	Activation of the “motor force” limiting device	During the movement, the door experienced excessive friction; identify the cause.
4 flashes 1 second pause 4 flashes	STOP input activation	At the start of the manoeuvre or during the movement, the STOP input was activated; identify the cause.

5.6.3 – Control Unit

On the control unit there is a set of LEDs, each of which can give special indications both during normal operation and in case of malfunctions.

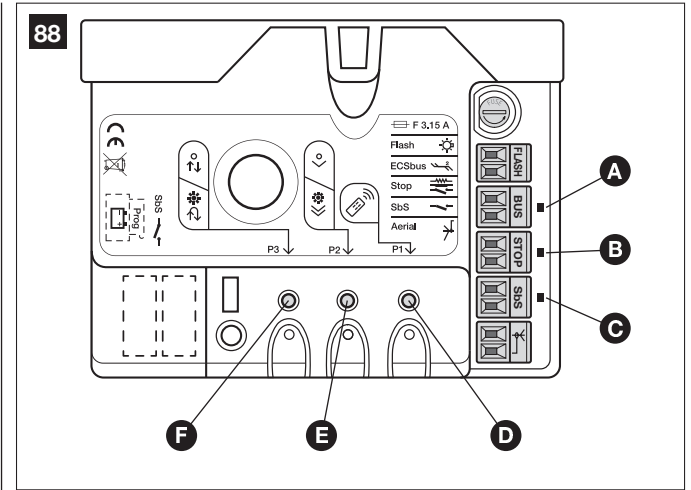

TABLE 16

LED OK [A]	Status	Action
Off	Fault	Make sure there is power supply; check to see if there are blown fuses; identify the cause of the malfunction and then replace blown fuses with others having the same characteristics.
On	Serious fault	This indicates a serious fault; try switching off the control unit for a few seconds; if the condition persists there is a fault and the electronic board needs to be replaced
1 flash per second	All OK	Normal operation of control unit
2 long flashes	Input status variation	It is normal when there is a variation to one of the inputs: SbS, STOP, triggering of photocells or the radio transmitter is used.
Series of flashes separated by a pause	It corresponds to the flashing and courtesy light's signal. (See Table 14)	
LED STOP [B]	Status	Action
Off	STOP input activation	Check the devices connected to the STOP input
On	All OK	STOP input active
LED SbS [C]	Status	Action
Off	All OK	SbS input not active
On	SbS input activation	This is normal only if the device connected to the SbS input is actually active
LED P1 [D]	Status	Action
Off	All OK	No memorisation in progress
On	Memorisation in Mode 1	This is normal during memorisation in mode 1 which lasts maximum 10s
Series of quick flashes, from 1 to 4	Memorisation in Mode 2	This is normal during memorisation in mode 2 which lasts maximum 10s
LED P2 [E]	Status	Action
Off	All OK	“Slow” speed selected
On	All OK	“Fast” speed selected
1 flash per second	No device has been memorised or an error has occurred in the memorised devices	There may be faulty devices; check and, if necessary, try repeating the recognition process (see paragraph 3.5.1 “Recognition of Connected Devices”).
2 flashes per second	Device recognition stage in progress	It indicates that the search for the connected devices is underway (this stage lasts a few seconds at the most).
LED P3 [F]	Status	Action
Off	All OK	Cyclic operation
On	All OK	Complete cyclic operation
1 flash per second	The positions have not been acquired.	Repeat the position recognition procedure again (see paragraph 3.5.2. “Recognition of the door’s open and closed positions”)
2 flashes per second	Position recognition procedure in progress	

TECHNICAL CHARACTERISTICS OF THE VARIOUS COMPONENTS OF THE PRODUCT

The product AVIO600 / AVIO1000 is produced by Nice S.p.a. (TV) I. In order to improve its products, Nice S.p.a. reserves the right to modify their technical characteristics at any time without prior notice. In any case, the manufacturer guarantees their functionality and fitness for the intended purposes. Note: all the technical characteristics refer to a temperature of 20°C.

DESCRIPTION	DATA	
	Model GD102	Model GD103
Type	Electromechanical gearmotor for automated sectional and overhead doors incorporating a control unit complete with radio receiver for "ECCO5..." transmitters.	
Adopted technology	24V=== motor, helical teeth reduction gear; drive guide with timing belt and mechanical release. A transformer inside the motor but separated from the control unit reduces mains voltage to the nominal voltage of 24V=== used by the automation system.	
Peak thrust [corresponds to the force necessary to move a leaf]	10,8 Nm [600 N]	18 Nm [1,000 N]
Nominal torque [corresponds to the force necessary to keep a leaf moving]	5,4 Nm [300 N]	9 Nm [500 N]
Idling speed	0,10 m/s in "slow" speed mode 0,18 m/s in "fast" speed mode	0,10 m/s in "slow" speed mode 0,15 m/s in "fast" speed mode
Speed at nominal torque	0,05 m/s in "slow" speed mode 0,09 m/s in "fast" speed mode	0,05 m/s in "slow" speed mode 0,08 m/s in "fast" speed mode
Maximum frequency of cycles	50 complete cycles per day (For a maximum of approx. 10 cycles per hour. A maximum of 5 cycles per hour is permitted at 50°C)	
Maximum continuous cycle time	4 minutes (the control unit limits the continuous operation)	
Operating Limits	Its structural characteristics make it suitable for use on sectional and overhead doors with counterweights that are within the dimensions and limits indicated in table 7	
Power supply AVIO	230 V~ (±10%) 50/60 Hz	
Max. absorbed power	250 W	370 W
Insulation class	I (a safety grounding system is required)	
Emergency power supply	---	with PR100 accessory
Flashing light output	For Led visual signalling devices (mod. FL200)	
Courtesy light	12V lamp maximum 10W BA15 socket (automotive type lamp), stays on 60s after the manoeuvre	
BUS output	One output with a maximum load of 1 ECSbus unit	One output with a maximum load of 6 ECSbus units
"SbS" input	For normally open contacts (the closing of the contact causes the "Step-by-Step" command)	
"STOP" input	For normally open contacts and/or for 8,2kΩ constant resistance, or normally closed contacts with recognition of the "normal" status (any variation from the memorised status causes the "STOP" command)	
Radio aerial input	52 Ω for RG58 or similar type of cable	
Maximum cable length	Mains power supply: 30 m; inputs/outputs: 20m with aerial cable preferably shorter than 5m (observe the directions regarding the minimum gauge and type of cable)	
Remote control possibility	With ECCO5... transmitters, the control unit can receive one or more of the following commands: "Step-by-Step", "Partial opening", "Open only" and "Close only"	
ECCO5... transmitters memorised	Up to 150 if memorised in mode 1	
Range of ECCO5... transmitters	From 10 to 50 m without aerial, from 50 to 100 m with aerial incorporated in the FL200 flashing light. The range can vary if there are obstacles or electromagnetic disturbances, and is affected by the position of the receiving aerial incorporated in the flashing light.	
Programmable functions	"Cycle" or "Complete cycle" operation (automatic closing) "Slow" or "fast" motor speed The pause time in the "complete cycle" mode can be set at 10, 20, 40, 80 seconds The sensitivity of the obstacle detection system can be selected from 4 levels The operation of the "Step-by-Step" command can be selected from 4 modes	
Self-programmed functions	Automatic detection of devices connected to the BUS Output. Automatic detection of the type of "STOP" device (NO or NC contact or 8,2kΩ resistance) Automatic detection of door length and calculation of deceleration points.	
Operating ambient temperature	-20°C...+50°C	
Assembly	Horizontal	
Protection rating	IP40	
Dimensions / weight	380 x 280 x h 110 mm / 4 kg	

— STEP 6 —

⚠ This user guide should be stored and handed to all users of the automation.

6.1 – WARNINGS

● **Keep at a safe distance from the moving door until it is completely open or closed; do not transit through the door until it is completely open and has come to a standstill.** ● **Do not let children play near the door or with its commands.** ● **Keep the transmitters away from children.** ● **Suspend the use of the automation immediately as soon as you notice something abnormal in the operation (noises or jolting movements); failure to follow this warning may cause serious danger and accidents.** ● **Do not touch moving parts.** ● **Regular maintenance checks must be carried out by qualified personnel according to the maintenance plan.** ● **Maintenance or repairs must only be carried out by qualified technical personnel.** ● **Send a command with the safety devices disabled:**

If the safety devices do not work properly or are out of order, the door can still be operated.

01. Command the door with the transmitter. If the safety devices give the enable signal, the door opens normally; otherwise, reattempt within 3 seconds and keep the control activated. **02.** After approximately 2 seconds the door will start moving in the “man present” mode, that is, so long as the control is kept activated the door will keep moving; as soon as the control is released the door will stop.

If the safety devices are out of order, arrange to repair the automation as soon as possible.

6.2 – Manually releasing and locking the gearmotor

The gearmotor is equipped with a mechanical system that allows for opening and closing the door manually.

Manual operation must be performed in the case of a power outage or in the event of anomalies affecting the system.

	<p>1 Pull the release cord down until you hear the carriage being released.</p> <p>2 The door can now be moved manually.</p> <p>The activation of the manual release may cause an uncontrollable movement of the door if the springs are weak or broken, or if the door is off-balance.</p>	
--	--	--

	<p>To restore the functionality of the automation system, move the door back in position until you hear the carriage being engaged.</p>
--	---

In the event of a gearmotor fault, it is still possible to try release the motor to check whether the fault lies in the release mechanism.

6.3 – Door Control

• **With radio transmitter**

The command associated to each button depends on how it has been memorised.

• **With button (integrated)**

<p>You can control the door movement by acting directly on the orange button [A]</p>	
---	--

6.4 – User-admissible maintenance operations

The operations that the user must carry out periodically are listed below:

- **Cleaning of the surfaces of the devices: use a slightly damp (not wet) cloth. Do not use substances containing alcohol, benzene, thinners or other flammable substances; the use of these substances may damage the devices and cause fires or electric shocks.**
- **Removal of leaves and stones: disconnect the power supply before proceeding, so as to prevent anyone from moving the door.**

6.5 – Replacing the transmitter battery

When the battery is flat, the transmitter capacity is significantly reduced. If, when a button is pressed, the relevant Led turns on then immediately fades and turns off, it means that the battery is completely flat and should be immediately replaced.

If instead the Led turns on only for a moment, it means that the battery is partially flat; the button must be kept pressed for at least half a second for the transmitter to attempt to send the command.

However, if the battery level is too low to complete the command (and possibly wait for the response), the transmitter will turn off and the relevant Led will fade. In these cases, normal transmitter operation can be restored by replacing the battery with another of the same type, while observing the relevant polarity. To replace the battery, proceed as shown below.

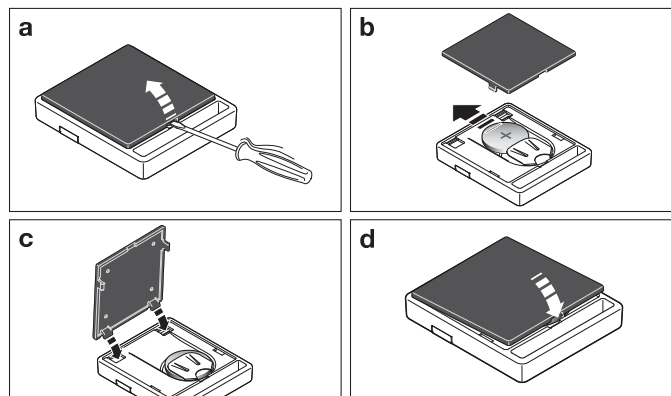

⚠ Batteries contain polluting substances: do not dispose of them together with common waste but use the methods set forth in the local regulations.

6.6 – Lamp replacement

Before proceeding, disconnect AVIO500 from the power supply.

- 1** Unscrew screw **[A]** and push button **[B]**, to open the lid.
- 2** Push the lamp up and rotate to remove. Insert a new 12V / 10W lamp with BA15 socket.

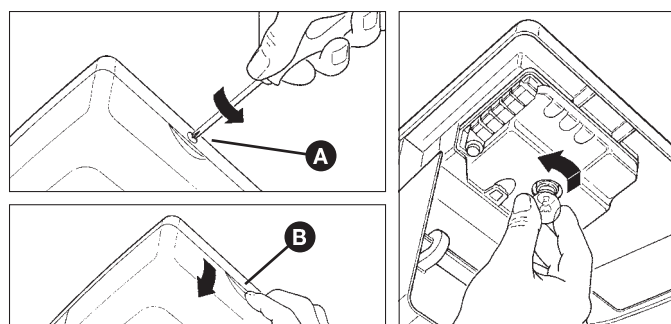

EC DECLARATION OF CONFORMITY

In conformity to Directive 2006/42/EC, ANNEX I, Part A (EC declaration of conformity for machinery)

The undersigned / company (name or company name of the subject who/that commissioned the motor-driven door):

.....

Address:

.....

Hereby declares under its/his/her sole responsibility that:

- **The automation:** motorized sectional door motorized overhead door

- **Serial N°:**

- **Year of manufacture:**

- **Location (address):**

.....

Complies with the essential requirements of the following directives:

2006/42/EC "Machines" Directive

and as provided for in the following harmonised standards:

EN 12445 "Industrial, commercial and garage doors and gates. Safety in use of Power-operated doors and gates – Test Methods"

EN 12453 "Industrial, commercial and garage doors and gates. Safety in use of Power-operated doors and gates – Requirements"

Name: Signature:

Date:

Place:



CE declaration of conformity and declaration of incorporation for a “quasi-machine”

Declaration in accordance with Directives: 1999/5/EC (R&TTE), 2014/30/EC (EMC); 2006/42/EC (MD) annex II, part B

Note - The content of this declaration corresponds to the declaration made in the official document filed in the offices of Nice S.p.a., and particularly the latest version thereof available prior to the printing of this manual. The text herein has been re-edited for editorial purposes. A copy of the original declaration can be requested from Nice S.p.a. (TV) IT.

Number: 582/AVIO **Revision:** 0 **Language:** EN

Name of manufacturer: Nice s.p.a.

Address: Via Pezza Alta 13, 31046 Rustignè, Oderzo (TV) Italy

Person authorised to provide technical documentation: Nice s.p.a.

Product type: Gearmotor 24Vdc assembled, with incorporated control unit and receiver

Model / Type: AVIO500C, AVIO600C, AVIO1000C, AVIO500CC

Accessories: GA2, GU2, PR100, KS200KIT, ECCO5BO, ECCO5WO

The undersigned Roberto Griffa, as Chief Executive Officer, hereby declares under his own responsibility that the products specified above comply with the provisions of the following directives:

- DIRECTIVE 1999/5/EC OF THE EUROPEAN PARLIAMENT AND COUNCIL of 9 March 1999 regarding radio equipment and communications terminals and the mutual recognition of their conformity in accordance with the following harmonised standards:
 - Health and safety: EN 62479:2010
 - Electrical safety: EN 60950-1:2006 + A11:2009 + A12:2011 + A1:2010 + A2:2013
 - Electromagnetic compatibility: EN 301 489-1 V1.9.2:2011; EN 301 489-3 V1.6.1:2013
 - Radio spectrum: EN 300 220-2 V2.4.1:2012
- DIRECTIVE 2014/35/EU OF THE EUROPEAN PARLIAMENT AND OF THE COUNCIL of 26 February 2014 on the harmonisation of the laws of the Member States relating to the making available on the market of electrical equipment designed for use within certain voltage limits (recast), according to the following standards: EN 60335-1:2002 + A1:2004 + A11:2004 + A12:2006 + A2:2006 + A13:2008 + A14:2010 + A15:2011; EN 60335-2-95:2015 + A1:2015, EN 62233:2008

The product also complies with the following directive in accordance with the requirements for “quasi-machines”:

Directive 2006/42/EC OF THE EUROPEAN PARLIAMENT AND COUNCIL of 17 May 2006 regarding machines and amending directive 95/16/EC (consolidated text)

- I declare that the pertinent technical documentation has been prepared in accordance with Annex VII B to Directive 2006/42/EC and that the following essential requirements have been met: 1.1.1 - 1.1.2 - 1.1.3 - 1.2.1 - 1.2.6 - 1.5.1 - 1.5.2 - 1.5.5 - 1.5.6 - 1.5.7 - 1.5.8 - 1.5.10 - 1.5.11
- The manufacturer agrees to send the national authorities pertinent information on the “quasi-machine” in response to a motivated request without affecting its intellectual property rights.
- If the “quasi-machine” is operated in a European country with an official language other than the language used in this declaration, the importer must associate a translation with this declaration.
- The “quasi-machine” must not be operated until the final machine in which it is to be incorporated is declared to conform to the provisions of Directive 2006/42/EC, if applicable to it.

The parts of the product which are subject to the following standards comply with them:
EN 13241-1:2003 + A1:2011; EN 12445:2000; EN 12453:2000; EN 12978:2003 + A1:2009

Oderzo, 28 July 2016

Eng. **Roberto Griffa**
(Chief Executive Officer)



Service Après Vente France

En cas de panne, merci de contacter obligatoirement
notre Service Après Vente par téléphone ou par email :

0 820 859 203

Service 0,15 €/min + prix appel

niceservice@niceforyou.com

Merci de ne pas retourner le produit en magasin

Worldwide Customer Service

customerservice@niceforyou.com



Nice S.p.A.
Via Pezza Alta, 13
31046 Oderzo TV Italy
info@niceforyou.com

www.niceforyou.com