

# MhouseKit GD1 - GD10



English

For the automation of a sectional or up-and-over door.



**Installation instructions and warnings**

# Information

This manual may be reproduced provided no part of it is omitted or modified. No part of this manual may be translated into other languages without the prior authorization and subsequent examination by MHOUSE.

MHOUSE disclaims all responsibility for damage resulting from improper use of its products. You are therefore invited to read this manual carefully.

MHOUSE, in order to improve its products, reserves the right to modify them at any time without prior notice. In any case, the manufacturer guarantees their functionality and fitness for the intended purposes.

For any information please contact:



MHOUSE S.r.l.

via Pezza Alta, 13, ZI 31046 Oderzo

Tel: 0422 202109

Fax: 0422 852582

email: info@mhouse.biz

http: www.mhouse.biz

# Contents

<b>1 Warnings</b>	<b>3</b>	<b>4 Maintenance</b>	<b>21</b>
<b>2 Product description</b>	<b>4</b>	4.1 Dismantling and Disposal	21
2.1 Applications	4	<b>5 Additional Information</b>	<b>22</b>
2.2 Description of the automation	4	5.1 Advanced Adjustments	22
2.3 Description of devices	5	5.1.1 Adjusting the Parameters with the Radio Transmitter	22
2.3.1 GD1K and GD10K Electromechanical Gearmotor	5	5.1.2 Checking the Adjustments with the Radio Transmitter	23
2.3.2 PH1 photocells (optional)	6	5.2 Optional Accessories	23
2.3.3 KS1 key-operated selector switch (optional)	6	5.3 Adding or Removing Devices	23
2.3.4 FL1 flashing light with incorporated aerial (optional)	6	5.3.1 ECSBus	23
2.3.5 TX4 radio transmitter	6	5.3.2 STOP Input	23
<b>3 Installation</b>	<b>7</b>	5.3.3 Recognition of Other Devices	24
3.1 Preliminary checks	7	5.3.4 Addition of Optional Photocells	24
3.1.1 Operating limits	8	5.4 Memorization of Radio Transmitters	25
3.1.2 Tools and Materials	8	5.4.1 Memorization Mode 1	25
3.1.3 List of cables	9	5.4.2 Memorization Mode 2	25
3.2 Preparing the Electrical System	9	5.4.3 Remote memorization	25
3.2.1 Connection to the Electrical Mains	9	5.4.4 Deleting a Radio Transmitter	26
3.3 Installation of the Various Devices	10	5.4.5 Deleting all the Radio Transmitters	26
3.3.1 Assembly of the guide supplied with GD1	10	5.5 Troubleshooting	26
3.3.2 Assembly of the guide supplied with GD10	11	5.6 Diagnostics and Signals	27
3.3.3 Fixing of the gearmotor to the guide	13	5.6.1 Photocells	27
3.3.4 Fixing of the gearmotor to the ceiling	13	5.6.2 Flashing and courtesy lights	27
3.3.5 Photocells (optional)	15	5.6.3 Control Unit	28
3.3.6 KS1 key-operated selector switch (optional)	15	<b>6 Technical characteristics</b>	<b>29</b>
3.3.7 FL1 flashing light (optional)	16	<b>7 Annexes</b>	<b>32</b>
3.3.8 Electrical connections to the control unit	17	7.1 Allegato 1: CE Declaration of Conformity of GD Components	33
3.4 Power Supply Connection	18	7.2 Annexe 2: CE Declaration of Conformity of Power Operated Sectional or Up-and-over Door	35
3.5 Initial checks	18	7.3 Annexe 3. OPERATING GUIDE	37
3.5.1 Recognition of Connected Devices	18	7.3.1 Safety regulations	37
3.5.2 Learning of the door's open and closed positions	19	7.3.2 Door Control	37
3.5.3 Testing the radio transmitter	19	7.3.3 Maintenance Operations to Be Performed by the User	38
3.6 Regulations	20	7.3.4 Replacing the Remote Control Battery	38
3.6.1 Selecting door speed	20	7.3.5 Lamp replacement	38
3.6.2 Selecting the type of operating cycle	20		
3.7 Testing and Commissioning	20		
3.7.1 Testing	20		
3.7.2 Commissioning	21		

# 1 Warnings

## Important installer and user safety instructions.

- If this is the first time that you install a GD sectional or up-and-over door automation system we recommend that you dedicate some of your time to reading this manual. You should read it before you start installing the system, so you don't have to rush to finish the work.

Keep all the components of the GD system handy so that you can read, check and verify all the information contained in this manual. However, do not carry out the adjustment and memorization stages otherwise, during the actual installation of the products, you will have to deal with settings that differ from the original factory ones.

- When reading this manual, pay special attention to the sections marked by the following symbol:



these sections are particularly important for safety.

- Store this manual safely for future use.
- This manual, as well as the design and manufacture of the devices that make up GD, comply fully with the standards and regulations in force.
- Considering the hazards that may exist during the installation and operation of GD, it is necessary that also the installation be carried out in strict compliance with current legislation, standards and regulations, particularly:
  - **This manual contains important information regarding personal safety; before you start installing the components, it is important that you read and understand all the information contained herein. Do not proceed with the installation if you have doubts of any sort; if necessary, refer to the MHOUSE customer service department for clarifications.**
  - **Follow all installation instructions.**
  - **Before you start with the installation, make sure that each single GD device is suitable for the intended automation purposes; pay special attention to the data provided in chapter 6 "Technical Characteristics". If even a single device is not suitable for the intended application, do not proceed with the installation.**
  - **Before you start with the installation, check whether additional devices or materials are needed to complete the automation with GD based on the specific application requirements.**
  - **The GD0 automation system must not be installed outdoors.**
  - **The GD automation system must not be used until the automation has been commissioned as described in paragraph 3.7.2 "Commissioning".**
  - **The GD automation system cannot be considered as a suitable intrusion protection system. If you require efficient protection you need to integrate GD with other devices.**
  - **The packing materials for GD must be disposed of in compliance with local regulations.**
  - **Do not make modifications to any components unless provided for in this manual. This type of operations will only cause malfunctions. MHOUSE disclaims any liability for damage resulting from modified products.**

- **Components must never be immersed in water or other liquids. Also during installation, do not allow liquids to enter the gearmotor or other open devices.**

- **In the event that liquid substances have penetrated inside the automation devices, immediately disconnect the power supply and contact the MHOUSE customer service department. The use of GD in these conditions can be dangerous.**

- **Keep all components of GD away from heat sources and open flames; these could damage the components and cause malfunctions, fire or dangerous situations.**

- **Connect the gearmotor only to a power supply line equipped with safety grounding system.**

- **All operations requiring the opening of the protection shell of GD device must be performed with the gearmotor disconnected from the power supply; if the disconnection device is not identifiable, post the following sign on it: "WARNING: MAINTENANCE WORK IN PROGRESS".**

- **In the event that any automatic switches or fuses are tripped, you must identify the failure and eliminate it before you reset them.**

- **If a failure occurs that cannot be solved using the information provided in this manual, refer to the MHOUSE customer service department.**

Particular warnings concerning the suitable use of this product in relation to the 98/37/CE "Machine Directive" (ex 89/392/EEC):

- This product comes onto the market as a "machine component" and is therefore manufactured to be integrated to a machine or assembled with other machines in order to create "a machine", under the directive 98/37/EC, only in combination with other components and in the manner described in the present instructions manual. As specified in the directive 98/37/CE the use of this product is not admitted until the manufacturer of the machine on which this product is mounted has identified and declared it as conforming to the directive 98/37/CE.

Particular warnings concerning the suitable use of this product in relation to the 73/23/EEC "Low Voltage" Directive and subsequent modification 93/68/EEC:

- This product responds to the provisions foreseen by the "Low Voltage" Directive if used in the configurations foreseen in this instructions manual and in combination with the articles present in the Mhouse S.r.l. product catalogue. If the product is not used in configurations or is used with other products that have not been foreseen, the requirements may not be guaranteed; the use of the product is prohibited in these situations until the correspondence to the requirements foreseen by the directive have been verified by those performing the installation.

Particular warnings concerning the suitable use of this product in relation to the 89/336/EEC "Electromagnetic Compatibility" Directive and subsequent modifications 92/31/EEC and 93/68/EEC:

- This product has been subjected to tests regarding the electromagnetic compatibility in the most critical of use conditions, in the configurations foreseen in this instructions manual and in combination with articles present in the Mhouse S.r.l. product catalogue. The electromagnetic compatibility may not be guaranteed if used in configurations or with other products that have not been foreseen; the use of the product is prohibited in these situations until the correspondence to the requirements foreseen by the directive have been verified by those performing the installation.

## 2 Product description

### 2.1 Applications

GD is a set of components designed for the automation of sectional or up-and-over doors in residential applications.

**Any applications other than those described above or under different conditions from those specified in this manual are forbidden.**

GD operates with electric power. In the event of a power failure, the gearmotor can be released using a suitable cord in order to move the door manually.

As an alternative, the optional accessory can be used on the GD10 model: PR1 buffer battery.

**Table 1: comparison of main features of the GD gearmotor**

Gearmotor type	GD1	GD10
Maximum torque (corresponding to the maximum force)	10.8Nm (600N)	18Nm (1000N)
Max. No. of ECSBus units	1	6
Emergency power supply	No	with PR1
Guide length	3x1m	4x1m

### 2.2 Description of the automation

To clarify a few terms and aspects of a sectional or up-and-over door automation system: In Figure 1 we provide an example of a typical GD1 and GD10 application:

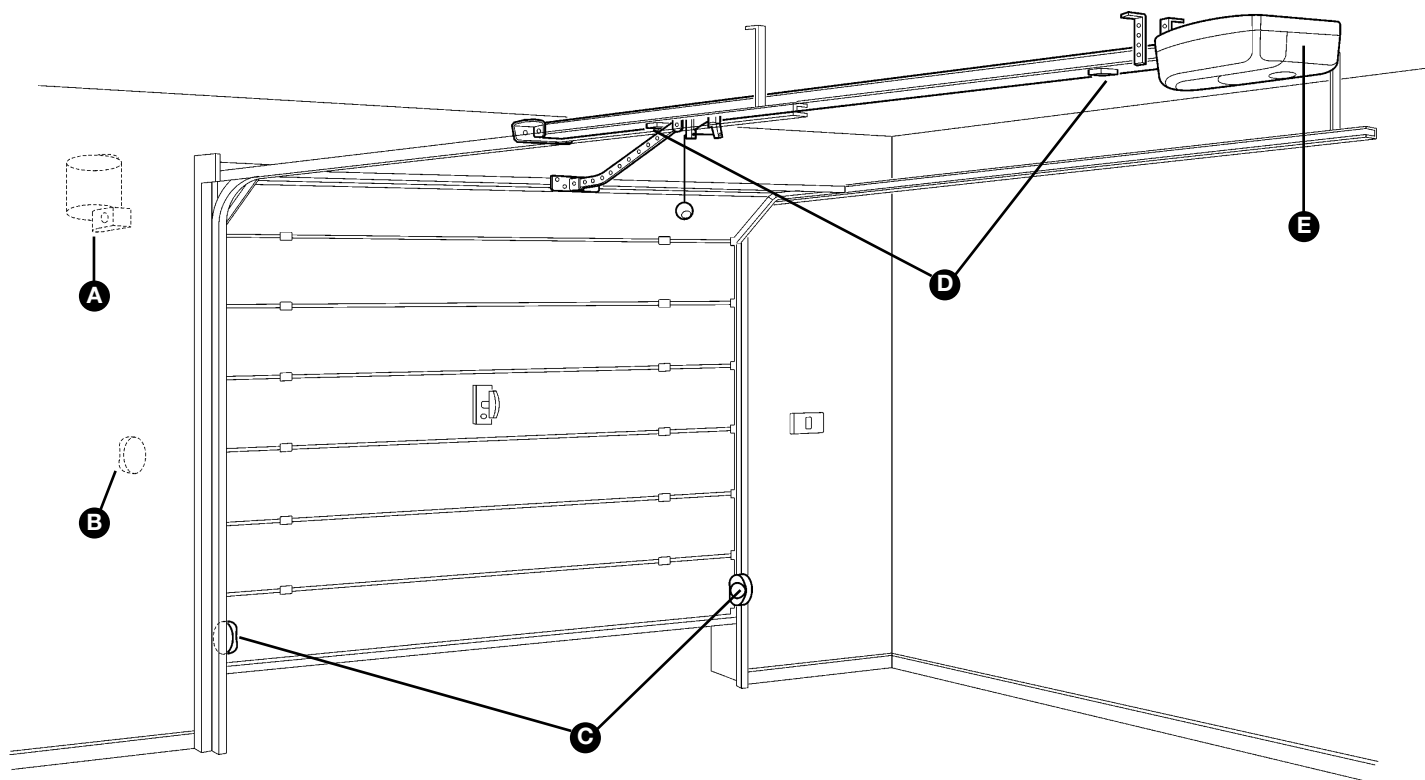

Figure 1

**[A]** FL1 flashing light with incorporated aerial (optional)

**[B]** KS1 key-operated selector switch (optional)

**[C]** Pair of PH1 photocells (optional)

**[D]** Mechanical stops

**[E]** GD1K and GD10K gearmotors

## 2.3 Description of devices

GD1 and GD10 can be made-up of the devices shown in Fig. 2 make immediately sure that they correspond to the contents of the package and verify the integrity of the devices.

Note: to adapt GD1 and GD10 to local regulations, the contents of the package may vary; an exact list of the contents is shown on the outside of the package under the "Mhousekit GD1 contains" and "Mhousekit GD10 contains" heading.

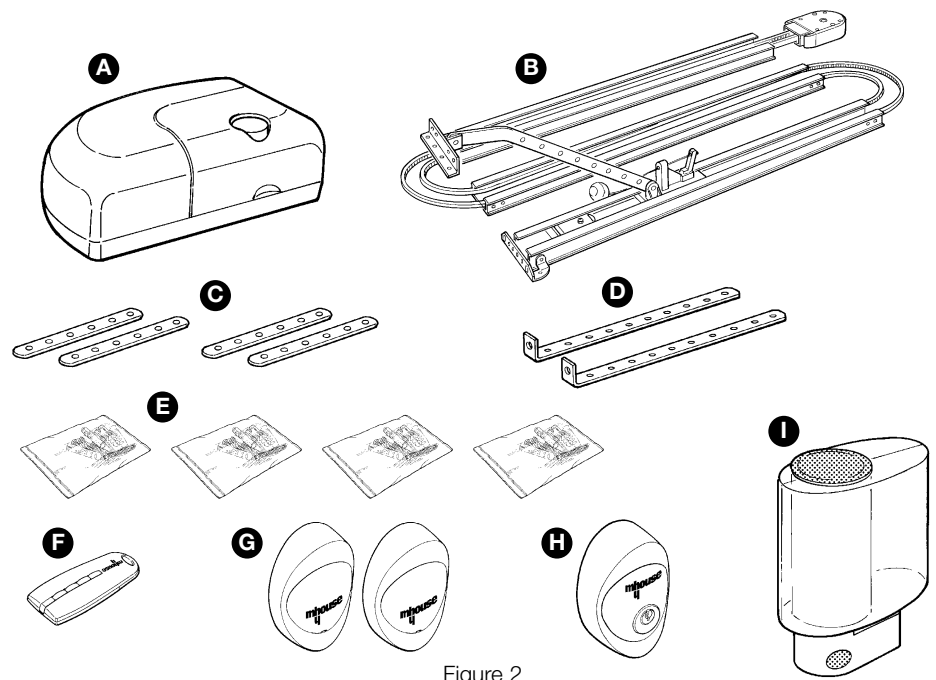

Figure 2

**Table 2: Component and accessories list**

Reference	GD1	GD10
<b>A</b>	1 GD1K electromechanical gearmotor with incorporated control unit.	1 GD10K electromechanical gearmotor with incorporated control unit.
<b>B</b>	1 3-metre guide with pre-assembled belt.	1 4-metre guide with pre-assembled belt.
<b>C</b>	4 coupling profiles	6 coupling profiles
<b>D</b>	2 ceiling-mounted brackets	2 ceiling-mounted brackets
<b>E</b>	Miscellaneous small parts: screws, washers, etc. see tables 1, 2, 3 and 4 (*).	Miscellaneous small parts: screws, washers, etc. see tables 1, 2, 3 and 4 (*).
<b>F</b>	1 TX4 radio transmitter.	1 TX4 radio transmitter.
<b>G</b>	PH1 pair of wall-mounted photocells	PH1 pair of wall-mounted photocells
<b>H</b>	KS1 key-operated selector switch	KS1 key-operated selector switch
<b>I</b>	FL1 flashing light with incorporated aerial.	FL1 flashing light with incorporated aerial.

\* The screws required for mounting GD1 and GD10 are not supplied as they depend on the type of material and its thickness.

### 2.3.1 GD1K and GD10K Electromechanical Gearmotor

GD1K and GD10K are electromechanical gearmotors made up of a 24Vdc motor. It features a mechanical release mechanism with cord that allows you to move the door manually in the event of a power failure. The gearmotor is fixed to the ceiling with the relative mounting brackets. The PR1 buffer battery can be used on the GD10 version, which allows some manoeuvres in the absence of the mains power supply.

The control unit actuates the gearmotors and provides for the control of the supply of the different components; it features an electronic board with incorporated radio receiver.

The control unit can actuate the gearmotor with two speeds: "slow" and "fast".

The three P1, P2 and P3 buttons **[B]** and the corresponding LED's are used to program the control unit.

The yellow button **[C]** allows the door to be controlled during testing. The same key will also be operated during daily use, through the incorporated orange button **[D]**.

To facilitate the electrical connections there are separate terminals for each device **[A]**, which are removable and colour-coded based on the function performed. Next to each input terminal there is a LED that signals its status

The connection to the power supply is very easy: just insert the plug in a power outlet.

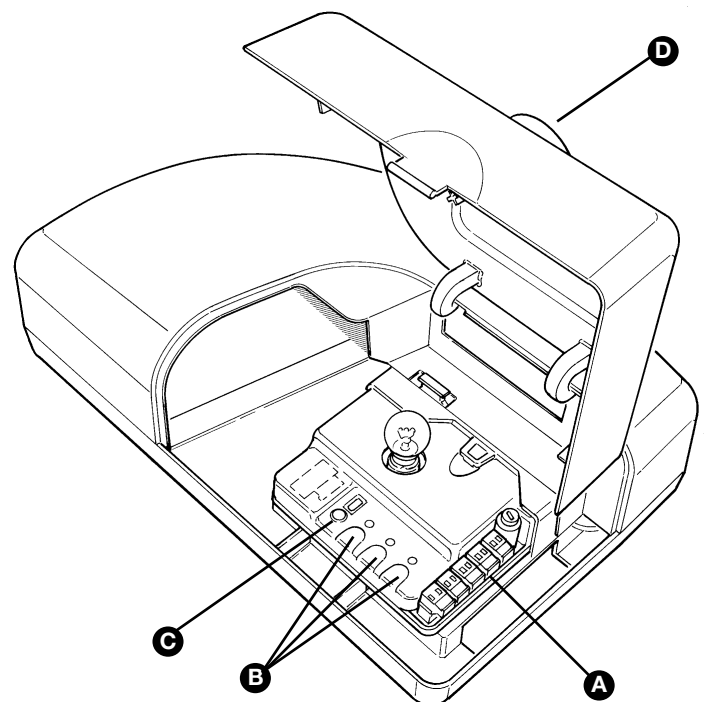

Figure 3

**Table 3: List of small parts**

	GD1K	GD10K
M6 self-tapping nuts	18 pcs	26 pcs
M6 x15 screws	18 pcs	26 pcs
6.3x45 tcei screws	4 pcs	4 pcs

### 2.3.2 PH1 photocells (optional)

The pair of PH1 wall-mounted photocells, once they are connected to the control unit, enables the detection of obstacles found on the optical axis between the transmitter (TX) and the receiver (RX).

**Table 4: List of small parts for PH1**

	<b>Q.ty</b>
HI LO 4X9.5 screw	4 pcs
3.5X25 self-tapping screw	4 pcs
s 5 c nylon screw anchor	4 pcs

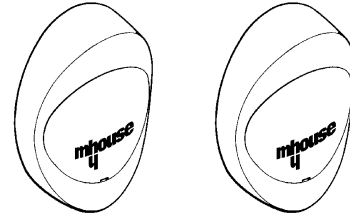

Figure 4

### 2.3.3 KS1 key-operated selector switch (optional)

The KS1 key-operated two-position selector switch enables door control without using the radio transmitter. It is equipped with internal light for locating in the dark.

There are two commands, which depend on the direction of rotation of the key: "OPEN" and "STOP"; then the key, which is spring loaded, returns to the centre position.

**Table 5: List of small parts for KS1**

	<b>Q.ty</b>
HI LO 4X9.5 screw	2 pcs
3.5X25 self-tapping screw	4 pcs
s 5 c nylon screw anchor	4 pcs

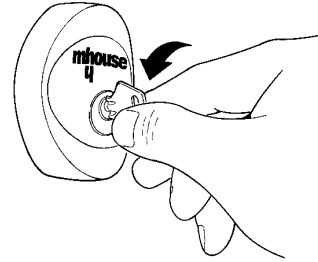

Figure 5

### 2.3.4 FL1 flashing light with incorporated aerial (optional)

The flashing light is controlled by the control unit and signals danger when the door is moving. Inside the flashing light there is also the aerial for the radio receiver.

**Table 6: List of small parts for FL1**

	<b>Q.ty</b>
4.2X32 self-tapping screw	4 pcs
s 6 c nylon screw anchor	4 pcs

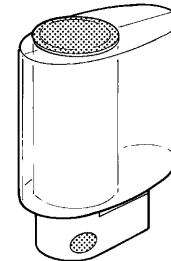

Figure 6

### 2.3.5 TX4 radio transmitter

The radio transmitter is used for the remote control of the door opening and closing manoeuvres. It features four buttons that can all be used for the 4 types of command to a single automation unit, or to control up to 4 different automation units.

The transmission of the command is confirmed by the LED **[A]**; an eye-let **[B]** allows them to be hung on a keyring.

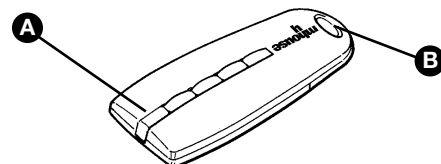

Figure 7

## 3 Installation

The installation must be carried out by qualified and skilled personnel in compliance with the directions provided in chapter 1 "WARNINGS".



### 3.1 Preliminary checks

The GD1 and GD10 must not be used to power a door that is not efficient and safe and cannot solve defects resulting from incorrect installation or poor maintenance of the door itself.

**WARNING:** incorrect installation could cause serious damage.

Before proceeding with the installation you must:

- Make sure that the door movement does not hinder roads or public footpaths.
- After the motor has been installed, remove unnecessary cables or chains and turn off any unneeded equipment
- Make sure that the weight and dimensions of the door fall within the specified operating limits (Chapter 3.1.1). If they do not, GD cannot be used.
- Make sure that the structure of the door is suitable for automation and in compliance with regulations in force.
- Make sure that there are no points of greater friction in the opening or closing travel of the door.
- Make sure that the mechanical structure of the door is sturdy enough and that there is no risk of derailing out of the guide.
- Make sure that the door is well balanced: it must not move by itself when it is placed in any position.
- Make sure that the installation area is compatible with the size of the gearmotor and that it is safe and easy to release it.
- Make sure that the mounting positions of the various devices are protected from impacts and that the mounting surfaces are sufficiently sturdy.
- Make sure that the mounting surfaces of the photocells are flat and that they enable the proper alignment between TX and RX.
- Pay attention in particular to the methods for securing the head of the guide and the brackets to the ceiling. The head of the guide will have to bear all the strain of opening and closing the door; the ceiling-mounted brackets will have to bear all the weight of GD. In both cases, the wear and deformations that may occur in time must be taken into consideration.
- Make sure that the minimum and maximum clearances specified in fig. 8 are observed.

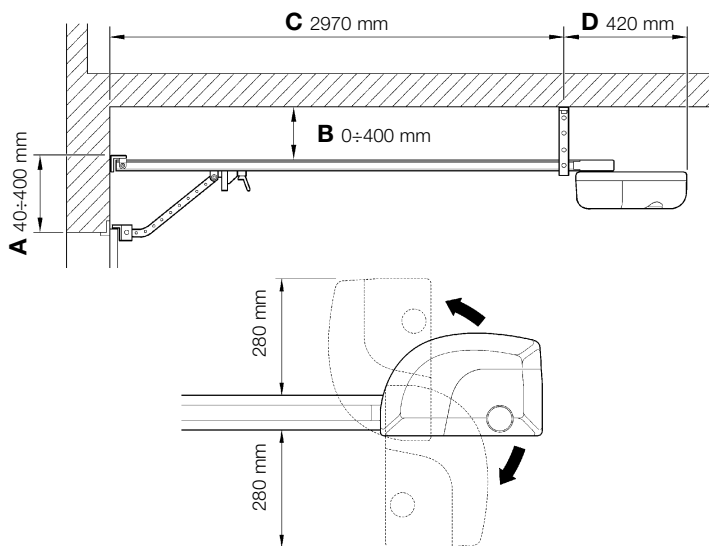

Figure 8

- The gearmotor should be mounted so that it coincides with the centre of the door, or is slightly off-centre, e.g. in order to mount the OSCILLATING ARM next to the handle (Figure 11).

- Make sure that, in the position corresponding to the door, or slightly to the side, (see positions "A" and "B") the conditions are suitable for mounting the head of the guide; in particular, the material should be sufficiently sturdy and compact.

Make sure that GD can be mounted on the ceiling along position "C" using the mounting brackets.

If the door to be automated is an up-and-over type door with springs or counterweights, it will be necessary to install an GA1 OSCILLATING ARM, which must be mounted next to the handle (Figure 11).

- Make sure that distance [E] in Figure 9, i.e. the minimum distance between the upper side of the guide and the maximum point reached by the upper edge of the door, is no shorter than 65 mm and no longer than 100 mm, otherwise GD cannot be installed.

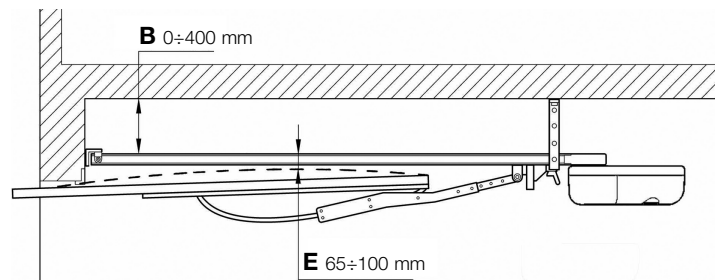

Figure 9

If the door closes a room that has no other means of access, we recommend installation of the GU1 EXTERNAL RELEASE KIT, otherwise a simple power failure will prevent access to the room (figure 10). Otherwise a fault or, for the GD1 version with buffer batteries, a simple power failure could prevent access to the room.

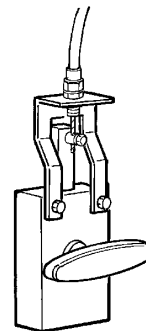

Figure 10

**Note:** the oscillating arm and external release kit are supplied with the related assembly instructions.

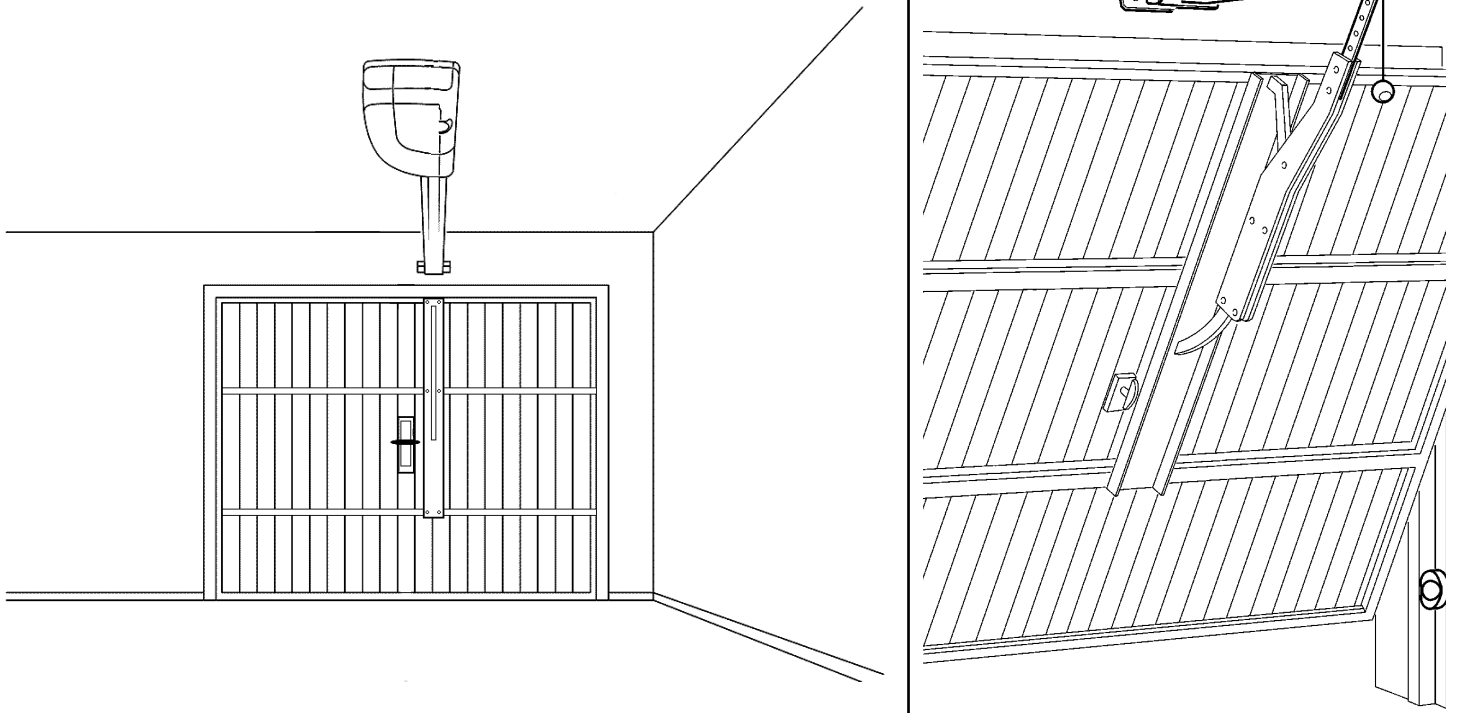

Figure 11

### 3.1.1 Operating limits

Chapter 6 “Technical Characteristics” provides the fundamental data needed to determine whether all the GD1 and GD10 components are suitable for the intended application.

In general the GD1 and GD10 are suitable for the automation of sectional and up-and-over doors for residential applications having the values shown in the table.

The shape of the door and the climatic conditions (e.g. presence of strong wind) may reduce this maximum limit. In this case it is necessary to measure the torque needed to move the door under the worst conditions, and to compare it to the data provided in the technical characteristics chart for the GD gearmotor.

**Table 7**

Model	Maximum power	SECTIONAL door		UP-AND-OVER door (with GA1 accessories)	
		Height	Width	Height	Width
<b>GD1</b>	600N	2.4m	3.5m	2.4m	3.5m
<b>GD10</b>	1000N	3.5m	5m	3.5m	3m

### 3.1.2 Tools and Materials

Make sure you have all the tools and materials needed to install the system; make sure that they are in good condition and serviceable according to current safety standards. See examples in figure 12.

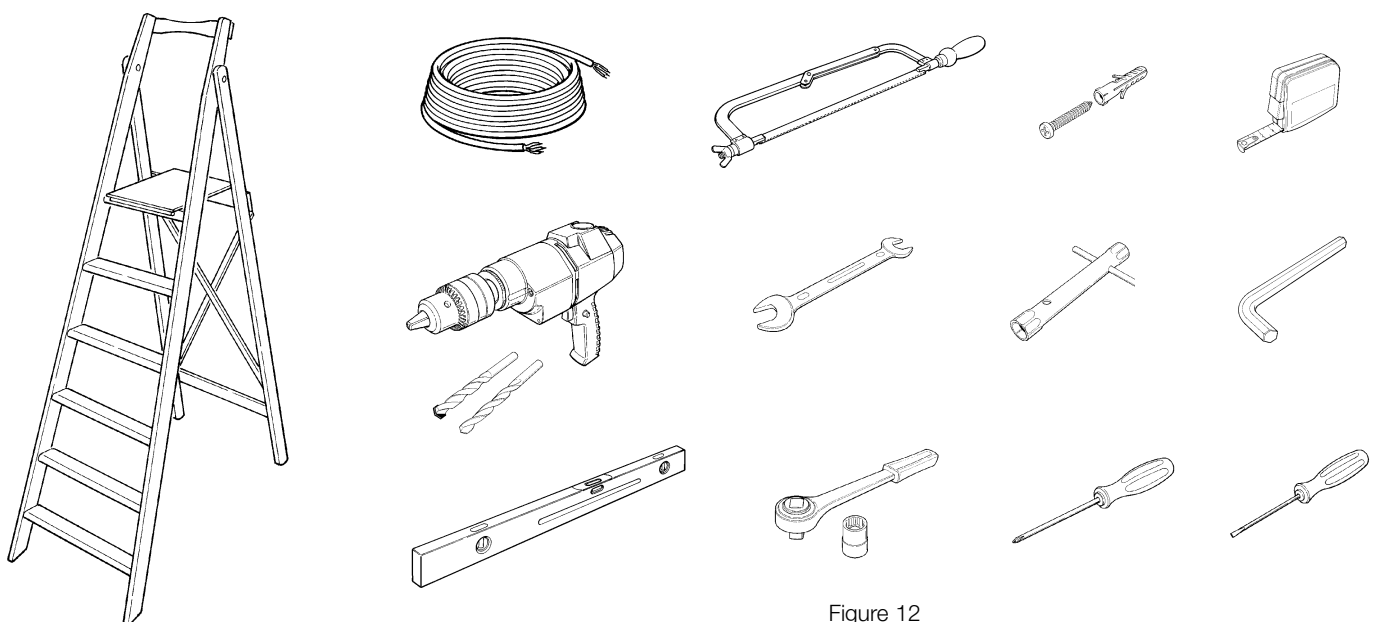

Figure 12



### 3.1.3 List of cables

The cables required for the installation of GD may vary depending on the type and quantity of devices to be installed; figure 13 shows the cables needed for a typical installation; no cable is supplied with GD.

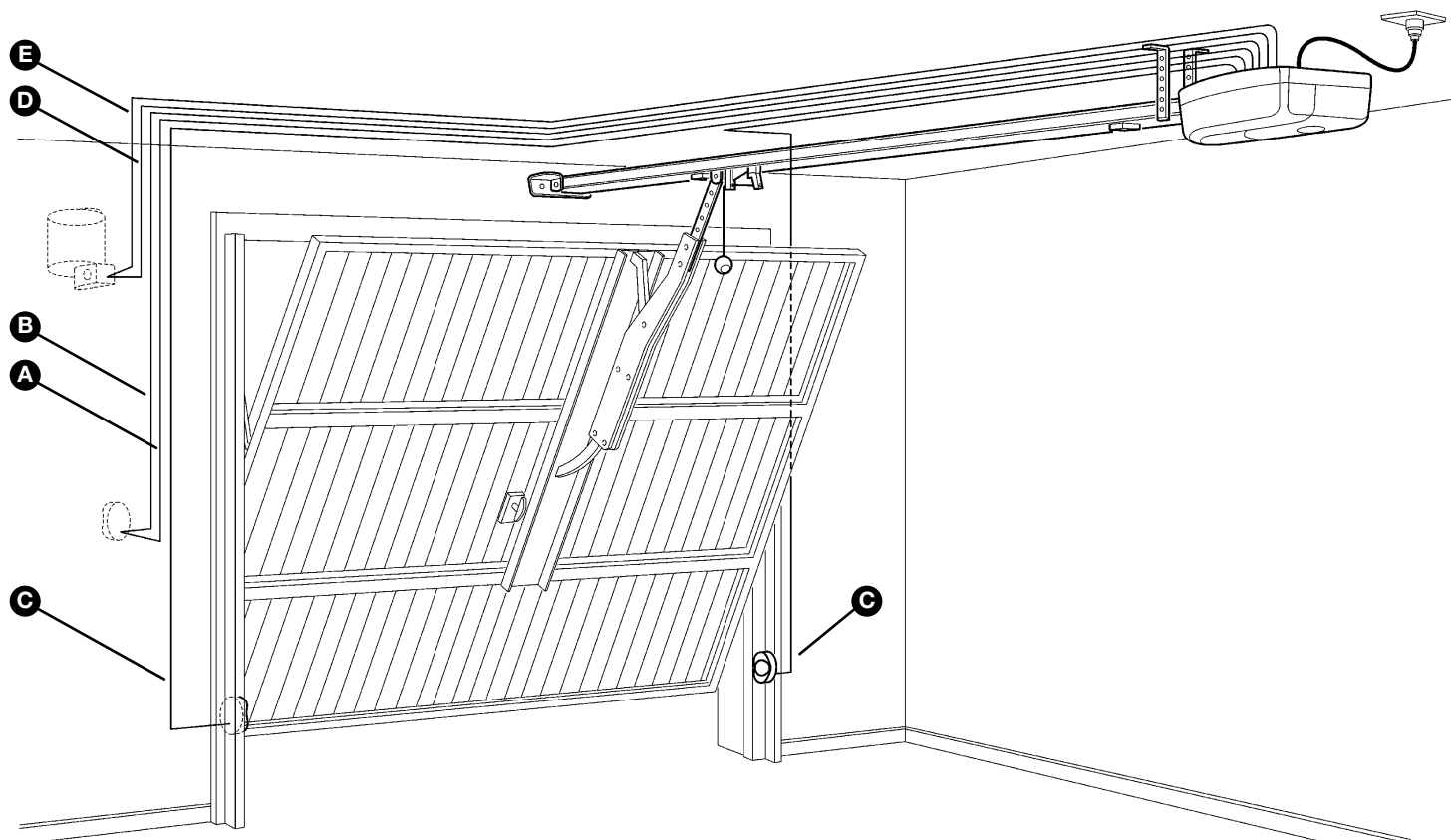

Figure 13

**Table 8: List of cables**

Connection	Cable type	Maximum length allowed
<b>[A]</b> STOP input	2x0,5mm <sup>2</sup> cable	20m (note 1)
<b>[B]</b> OPEN input	2x0,5mm <sup>2</sup> cable	20m (note 1)
<b>[C]</b> ECSBus input/output	2x0,5mm <sup>2</sup> cable	20m (note 1)
<b>[D]</b> FLASH light output	2x0,5mm <sup>2</sup> cable	20m
<b>[E]</b> Radio aerial	RG58 type shielded cable	20m (recommended less than 5m)

**WARNING: the cables used must be suitable for the type of installation; for example, an H03VV-F type cable is recommended for indoor applications.**

**Note 1:** For the ECSbus, STOP and OPEN cables, there are no special contraindications to the use of a single cable that groups together multiple connections; for example, the STOP and OPEN inputs can be connected to the KS1 selector switch using a single 4x0,5mm<sup>2</sup> cable.

## 3.2 Preparing the Electrical System

With the exception of the plug and the power cable, the rest of the system uses extra-low voltage (approx. 24V); the wiring can therefore be done by personnel that is not properly qualified, provided that all the instructions in this manual are carefully observed.

After selecting the position of the various devices (refer to figure 12) you can start preparing the conduits for the electrical cables connecting the devices to the control unit.

The shock-resistant conduits are designed to protect the electrical cables and prevent accidental breakage.

Install any fixed control close to the door but away from moving parts and at a height of 1.5m.

### 3.2.1 Connection to the Electrical Mains

Although the connection of GD to the electrical mains is beyond the scope of this manual, we wish to remind you that:

- The power supply line must be laid and connected by a qualified professional electrician.
- Have a suitably protected 16A “schuko” outlet installed, where you can plug in GD.

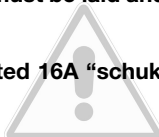

- Make sure that the power supply cable does not hang over moving parts or hazardous areas

- The electric line must be grounded and protected against short circuits; a bipolar disconnection device must also be present with contact separation of at least 3 mm, which allows the power supply to be disconnected during the installation and maintenance of the GD.

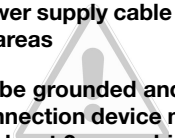

## 3.3 Installation of the Various Devices

Depending on the model, the installation of the GD is comprised of the following parts:

- Assembly of the guide supplied with GD1 (see paragraph 3.3.1)
- Assembly of the guide supplied with GD10 (see paragraph 3.3.2)
- Fixing of the gearmotor to the guide (see paragraph 3.3.3)
- Fixing of the gearmotor to the ceiling (see paragraph 3.3.4)

### 3.3.1 Assembly of the guide supplied with GD1

**1** Prepare the three parts that make up the guide, with the belt assembled so that they can be joined together. Pay attention to the position of the belt: the teeth must face inward and it must not be twisted.

**2** First of all, assemble the head of the guide **[A]** as shown in Figure 14. Attaching this part requires a certain amount of force.

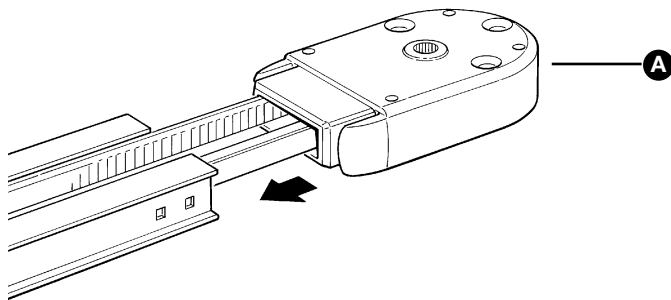

Figure 14

**3** Take the mounting brackets **[B]** from the box of accessories, join the three parts together **[C]** and secure them with the M6x14 screws and M6 nuts.

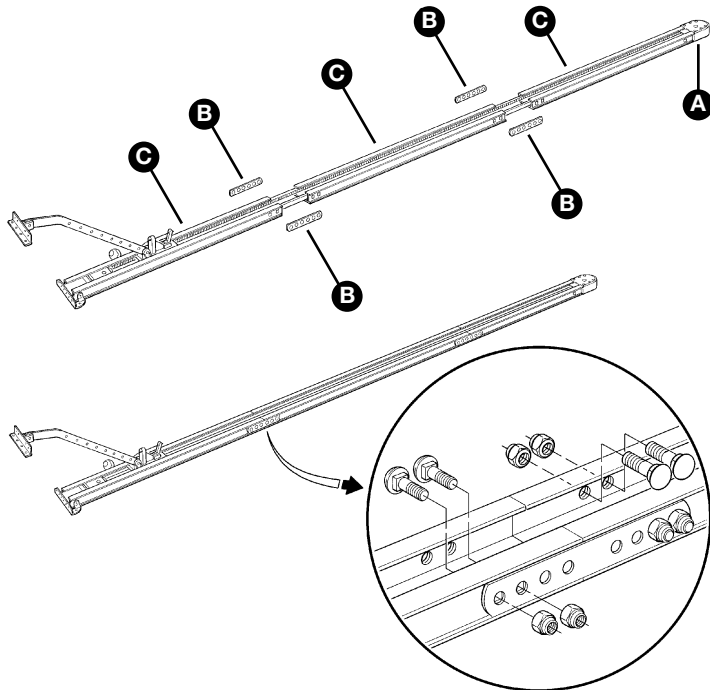

Figure 15

**4** Operating the nut **[D]**, tighten the belt until it is sufficiently rigid.

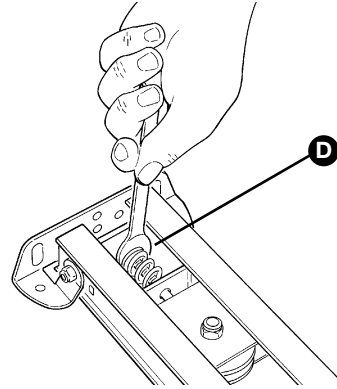

Figure 16

### 3.3.2 Assembly of the guide supplied with GD10

The guide is made up of four 1 m long profiles, which permit 2 versions to be made:

#### 3m version:

If the height of the door to be automated is equal to or less than 2.5 m assemble the guide as follows:

**1** Cut the free end of the belt to obtain a length of exactly 2 metres, as shown in figure 17.

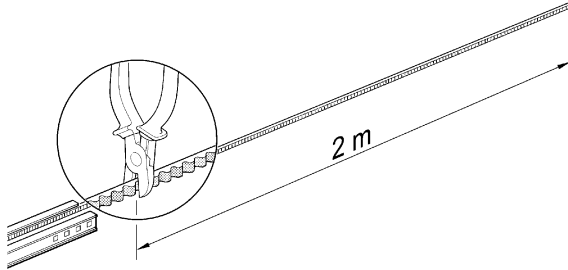

Figure 17

**2** Loosen the M8 nut **[D]** completely, as shown in figure 18.

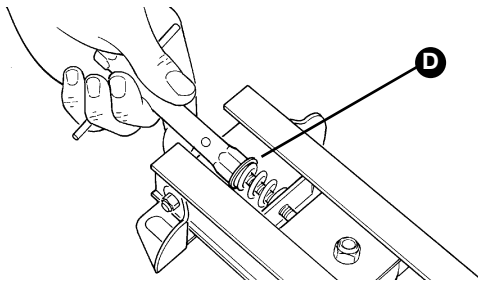

Figure 18

**3** Slide the belt tensioner device to mid-stroke **[E]**, as shown in figure 19, and remove the carriage completely.

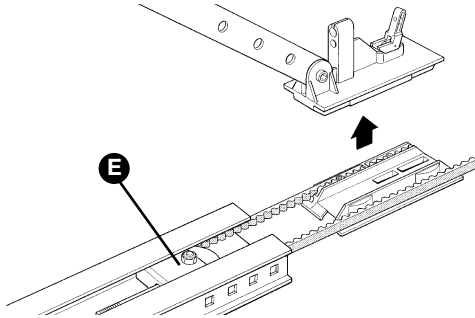

Figure 19

**4** Pass the free end of the belt through the head section, as shown in figure 20, and secure to the carriage by means of the screws and washers present, as shown in figure 21. Take care when positioning the belt; the teeth must be facing inwards, and it must be straight without twists.

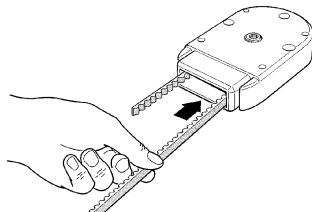

Figure 20

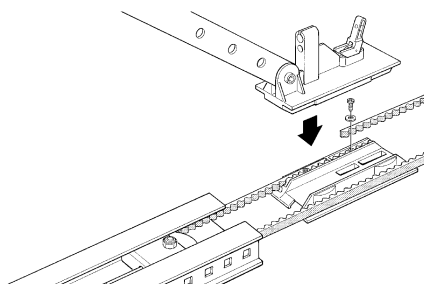

Figure 21

**5** Return the belt tensioner device and carriage to the initial position. Assemble the guide head section **[A]**, as shown in figure 22. This requires a certain force; if necessary use a rubber mallet.

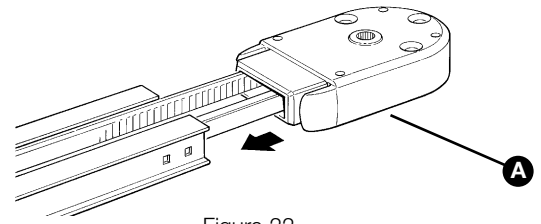

Figure 22

**6** Insert the spring, washer and M8 nut **[D]**, in the screw of the belt tensioner device, as shown in figure 23.

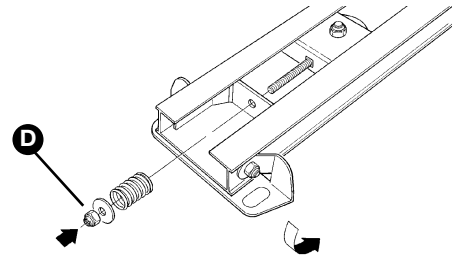

Figure 23

**7** Take the connecting bracket **[B]** from the accessories box, fix the three parts **[C]** together, securely tightening the M6x14 screws and M6 nuts, as shown in fig. 32

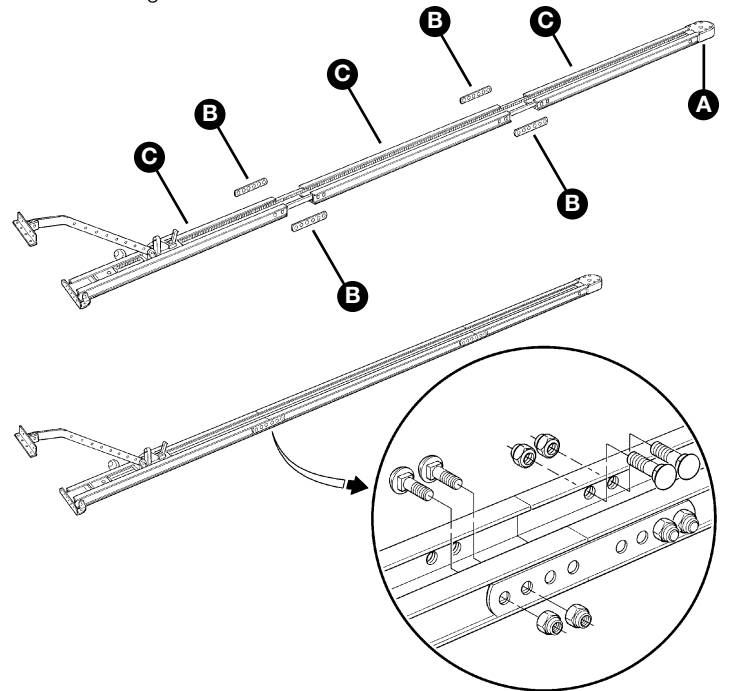

Figure 24

**8** Tension the belt by means of the M8 nut **[D]** (figure 25) until it is sufficiently taut.

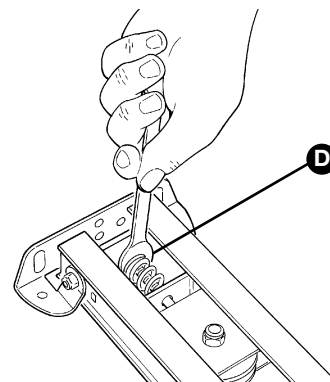

Figure 25

**4m Version:**

If the height of the door to be automated is greater than 2.5m assemble the guide as follows:

**1** Loosen the M8 nut **[D]** completely, as shown in figure 26.

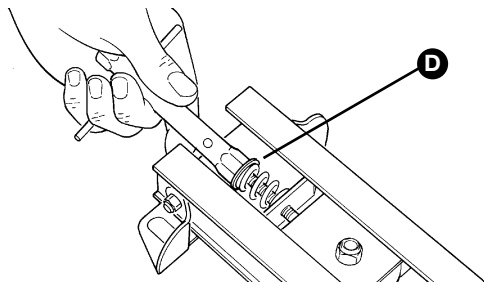

Figure 26

**2** Slide the belt tensioner device to mid-stroke **[E]**, as shown in figure 27, and remove the carriage completely.

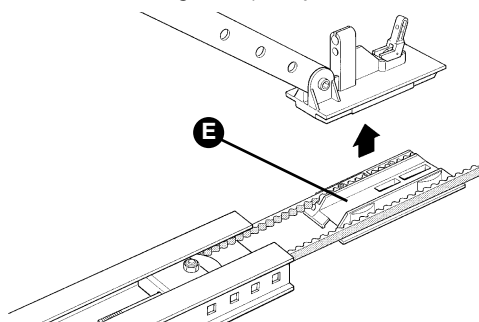

Figure 27

**3** Pass the free end of the belt through the head section, as shown in figure 28, and secure to the carriage by means of the screws and washers present, as shown in figure 29. Take care when positioning the belt; the teeth must be facing inwards, and must be straight without twists.

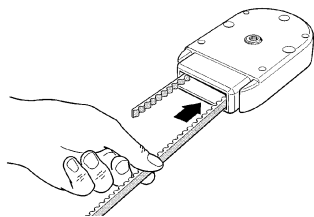

Figure 28

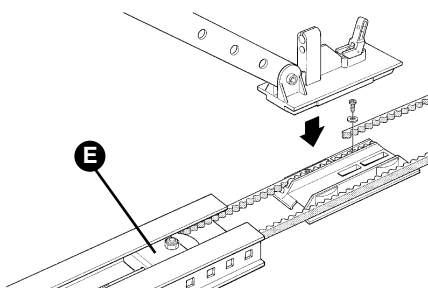

Figure 29

**4** Return the belt tensioner device and carriage to the initial position. Assemble the guide head section **[A]**, as shown in figure 30. This requires a certain force; if necessary use a rubber mallet.

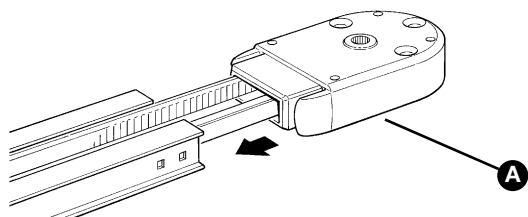

Figure 30

**5** Insert the spring, washer and M8 nut **[D]**, in the screw of the belt tensioner device, as shown in figure 31.

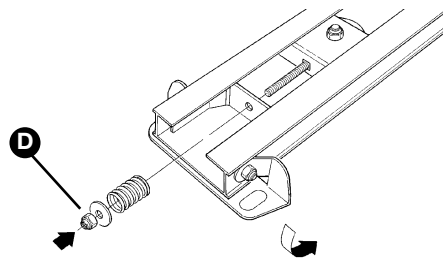

Figure 31

**6** Take the connecting bracket **[B]** from the accessories box, fix the four parts **[C]** together, securely tightening the M6x14 screws and M6 nuts, as shown in fig. 32

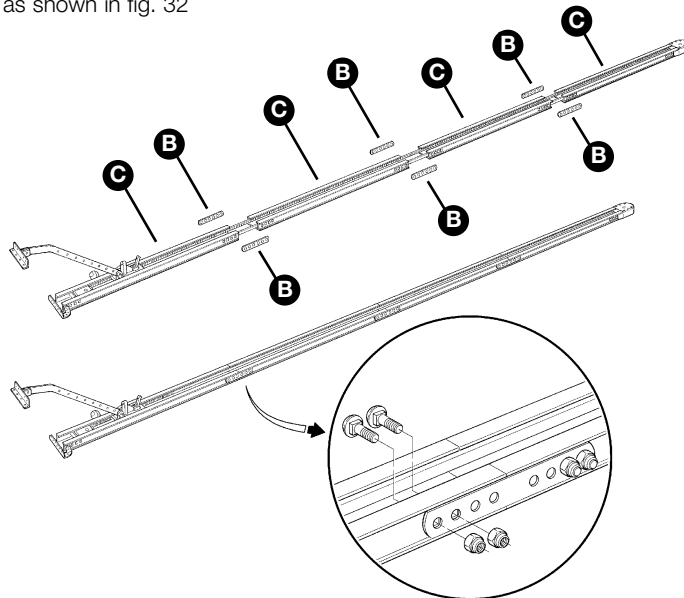

Figure 32

**7** Tension the belt by means of the M8 nut **[D]** (figure 33) until it is sufficiently taut.

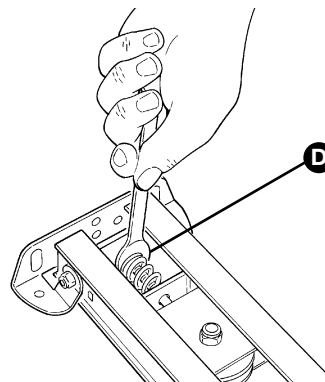

Figure 33

### 3.3.3 Fixing of the gearmotor to the guide

**1** Couple the gearmotor's shaft extension with the head of the guide **[A]**, then secure them using the four M6.3x45 screws **[F]**.

The gearmotor can be rotated in three different positions

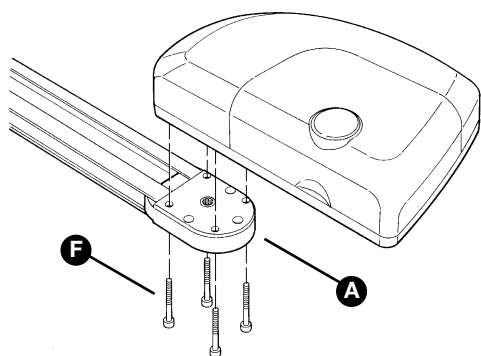

Figure 34

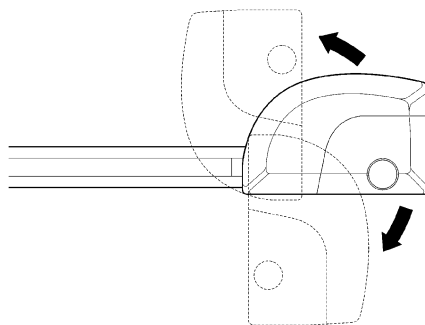

Figure 35

### 3.3.4 Fixing of the gearmotor to the ceiling

**1** Observing the A, B and C positions shown in Figure 8, mark the 2 fastening points for the guide's front bracket in the centre of the garage door (or slightly off-centre - Figure 11).

Depending on the type of material, the front bracket can be fastened using rivets, anchors or screws (Figure 36). If positions A, B, and C (figure 8) allow it, the bracket can be fastened directly to the ceiling.

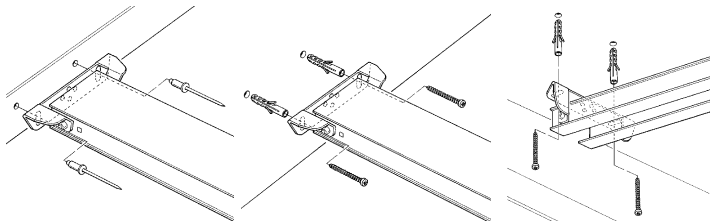

Figure 36

**2** After drilling the holes, leave the head of the gearmotor on the ground, lift the guide from the front and secure it with two screws, anchors or rivets depending on the type of surface.

**3** Secure the mounting brackets **[I]**, using the screws **[G]** and nuts **[H]**, and choosing the hole that is closest to the established position B (see Figure 8).

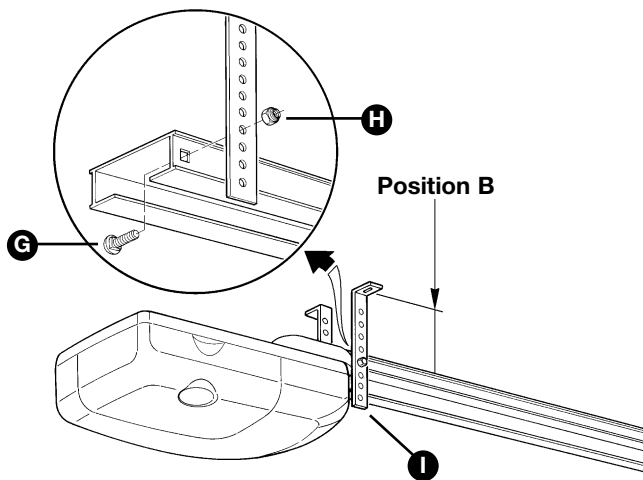

Figure 37

**4** Using a ladder, lift the gearmotor and position the brackets against the ceiling. Mark the drilling points, then put the gearmotor back on the ground.

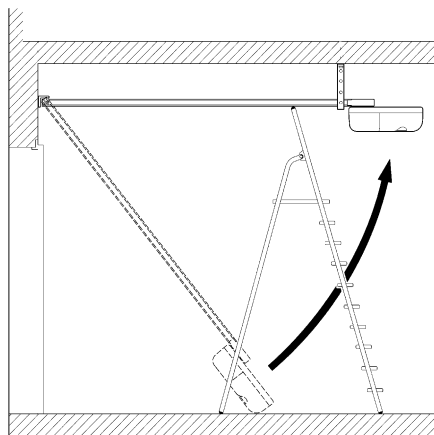

Figure 38

**5** Drill the holes as marked; then, using a ladder, lift the gearmotor, position the brackets over the holes you have just drilled and fasten them using screws and anchors suited to the material.

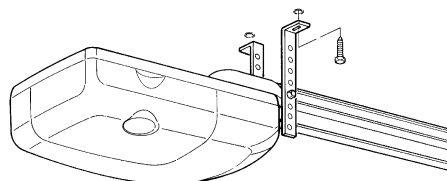

Figure 39

**6** Make sure that the guide is perfectly horizontal, then cut the excess of the brackets using a hacksaw.

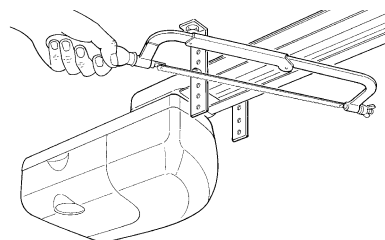

Figure 40

**7** With the door closed, pull the cord and release the carriage **[L]** from the guide.

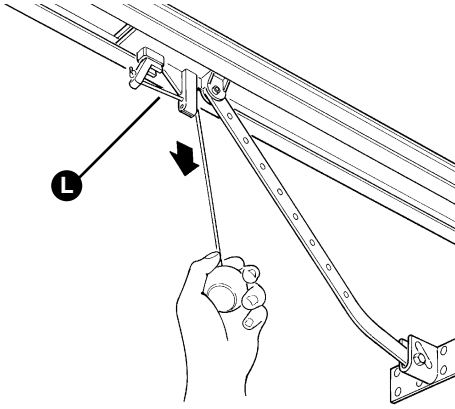

Figure 41

**8** Slide the carriage until the door mounted bracket **[N]** shown in Figure 42 is positioned on the upper edge of the door, exactly perpendicular to the guide **[M]**. Next, secure the door mounted bracket **[N]** with screws or rivets. Use screws or rivets that are suitable for the door material, making sure that they are capable of bearing all the strain resulting from opening and closing the door.

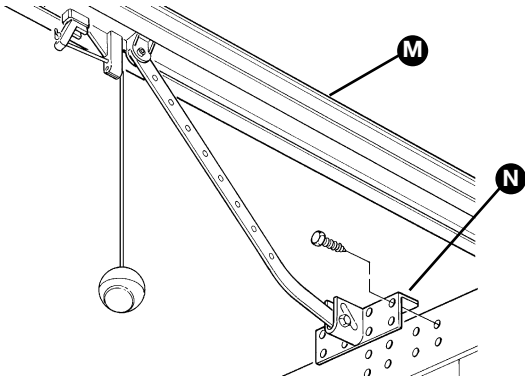

Figure 42

**9** Loosen the screws in the two mechanical stops, then place the front mechanical stop **[O]** before the carriage (Figure 43). Push the carriage hard in the closing direction and, in the reached position, tighten the screw firmly **[P]**.

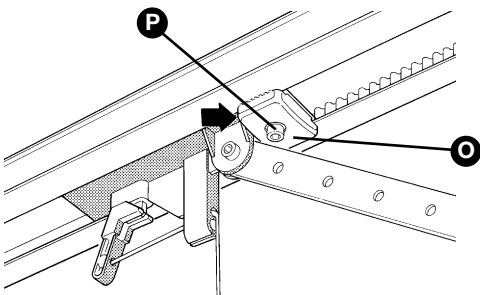

Figure 43

**10** Open the door manually to the desired open position, then place the rear mechanical stop **[Q]** near the carriage (Figure 44), and secure it tightening the screw firmly **[R]**.

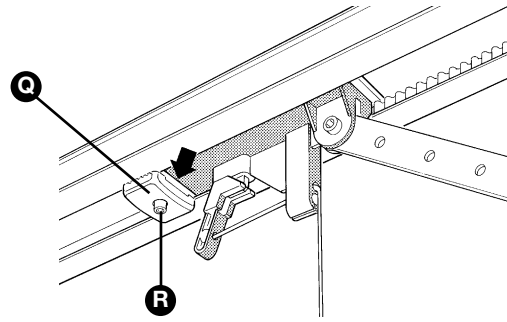

Figure 44

**11** Make sure that the release cord can be activated at a height less than 1.8m.

### 3.3.5 Photocells (optional)

**1** Select the position of the two elements that make up the photocell (TX and RX) observing the following directions:

Position them at a height of 20-25 cm from the ground, on both sides of the area to be protected and as close as possible to the edge of the door. With sectional doors, the photocells can be mounted outside, whereas with up-and-over doors they can only be mounted inside (outside they would obstruct the movement of the door)

- Point transmitter TX towards receiver RX, with a maximum tolerance of 5°.
- In the selected locations there must be a conduit for threading the cables.

**2** Remove the front glass **[A]** by prising it out with a slotted tip screwdriver applied to the bottom.

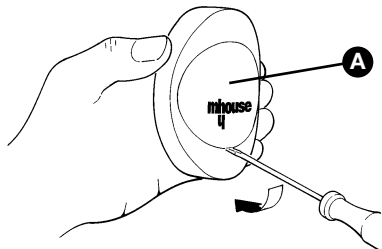

Figure 45

**3** Press the lens in order to separate the two shells.

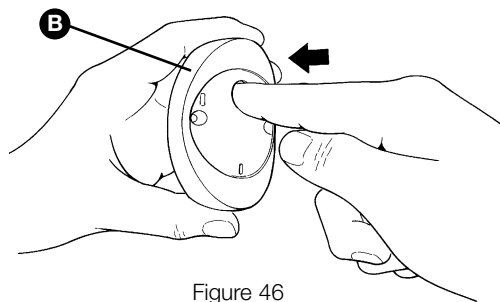

Figure 46

**4** Breach two of the four holes **[B]** at the bottom with a screwdriver.

**5** Position the photocell at the point where the conduit arrives; the hole at the bottom **[D]** should match the point where the cables come out of the wall; mark the drilling points using the bottom as reference.

**6** Drill the holes in the wall using a hammer drill with a 5 mm bit and insert the 5 mm screw anchors.

**7** Secure the bottom with the screws **[C]**.

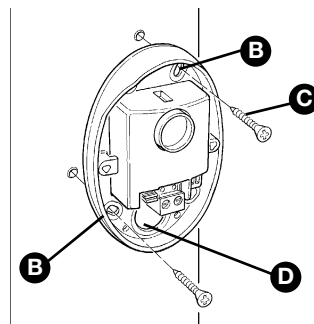

Figure 47

**8** Connect the electric cable to the appropriate TX and RX terminals. From an electrical viewpoint, TX and RX must be connected in parallel as shown in figure 48.

It is not necessary to observe any polarity.

The terminals can be removed in order to facilitate the operations; make the connections and then reinsert them.

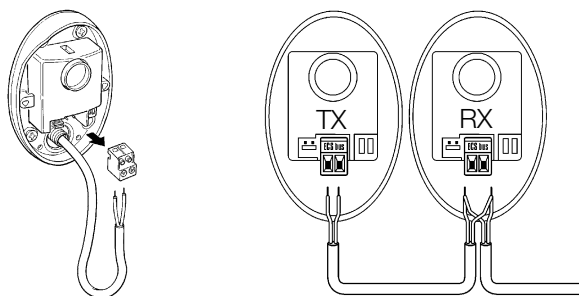

Figure 48

**9** Secure the cover shell **[E]** using the two screws **[F]** and a Phillips screwdriver. Then insert the glass **[G]**, pressing it gently to close it.

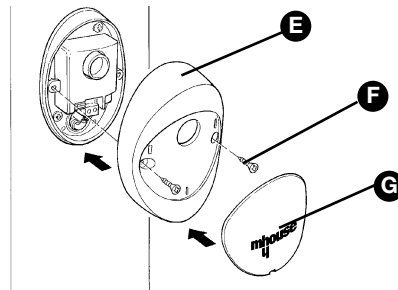

Figure 49

### 3.3.6 KS1 key-operated selector switch (optional)

**1** Determine the position of the selector switch; it must be installed outdoors, alongside the gate and at a height of approx. 80 cm, so that it can be used by people of different height.

**2** Remove the front glass **[A]** by prising it out with a slotted tip screwdriver applied to the bottom.

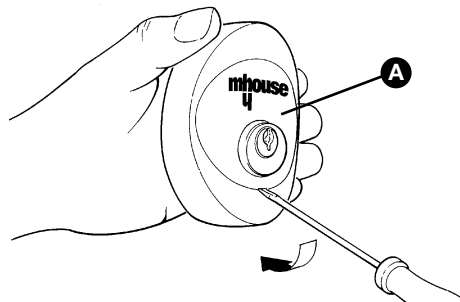

Figure 50

**3** To separate the bottom from the shell you need to insert the key and keep it turned, then pull with a finger inserted in the hole for the passage of the cables,

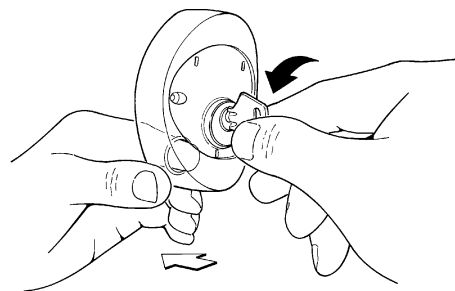

Figure 51

**4** Breach the four holes at the bottom with a screwdriver; mark the drilling points using the bottom as reference; make sure that the hole in the bottom matches the outlet for the cables.

**5** Drill the holes in the wall using a hammer drill with a 5 mm bit and insert the 5 mm screw anchors.

**6** Secure the bottom using the four screws **[A]**.

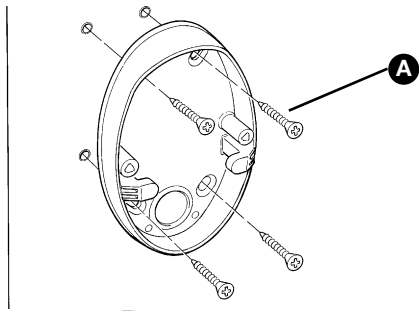

Figure 52

**7** Connect the electric cables to the appropriate OPEN and STOP terminals, as shown in figure 53. It is not necessary to observe any polarity. The terminals can be removed in order to facilitate the operations; make the connections and then reinsert them.

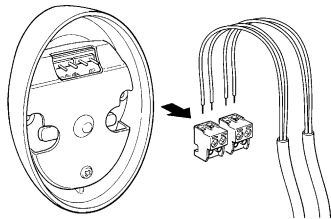

Figure 53

**8** To insert the shell on the bottom you need to turn the key. After you have inserted it, turn the key back to the centre position.

**9** Secure the body **[C]** using the two screws **[D]** and a Phillips screwdriver. Finally insert the glass **[E]**, pressing it gently to close it (Figure 54).

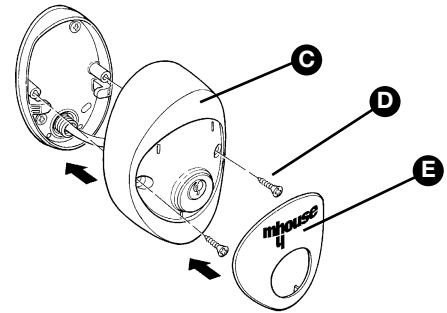

Figure 54

### 3.3.7 FL1 flashing light (optional)

**1** Determine the position of the flashing light: it should be near the door and easy to see; it can be secured to a horizontal as well as vertical surface.

**2** Slide out the diffuser **[A]** from the bottom by pressing the two buttons **[B]**.

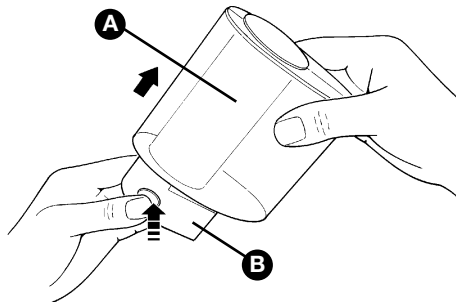

Figure 55

**3** Separate the lamp holder with the aerial from the base.

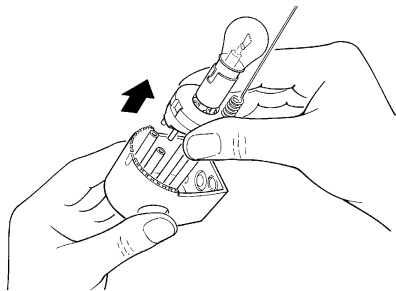

Figure 56

**4** Breach the four holes for the screws and the hole for the passage of the cables in the bottom or side, depending on the installation position, using a screwdriver.

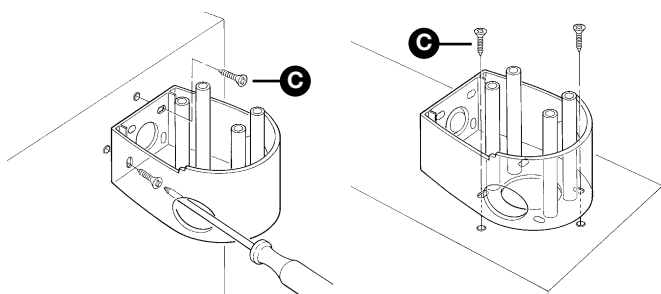

Figure 57

**5** Mark the drilling points using the bottom as reference and make sure that the hole in the bottom matches the outlet for the cables.

**6** Drill the holes in the wall using a hammer drill with a 6 mm bit and insert the 6 mm screw anchors.

**7** Secure the bottom with the screws **[C]**.

**8** Connect the electrical cables to the appropriate FLASH and "aerial" terminals as shown in figure 58. You do not need to observe any polarity on the FLASH terminal; however, for the connection of the shielded cable to the aerial, connect the braid as shown in figure 59. The terminals can be removed in order to facilitate the operations; make the connections and then reinsert them (Figure 60).

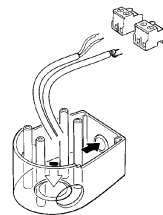

Figure 58



Figure 59

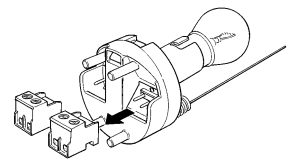

Figure 60

**9** Fit the lamp holder on the base and press it down until it snaps into position.

**10** Slide in the diffuser, pressing the buttons and fitting it on the bottom. Rotate it in the desired direction then press it down until the two buttons snap into their seat.

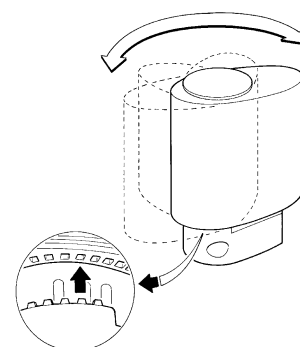

Figure 61



### 3.3.8 Electrical connections to the control unit

1 Open the cover by loosening screw **[A]** and pushing point **[B]**.

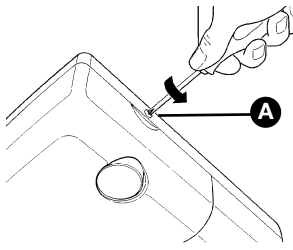

Figure 62

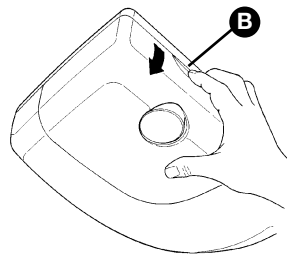

Figure 63

2 Thread the cables through the slit **[C]**.

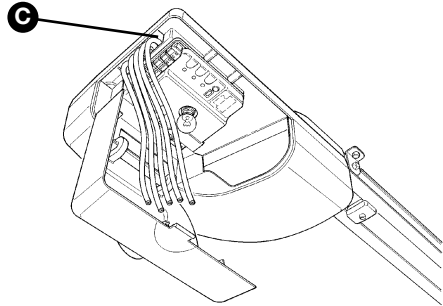

Figure 64

3 Refer to figure 65 for the electrical extra low voltage connection of the various devices to the control unit terminals.

- The terminals have the same colour coding as the corresponding devices; for example, the grey terminal (OPEN) of the control unit must be connected to the grey terminal (OPEN) of the KS1 selector (optional accessory).
- For most connections you do not need to observe any polarity; only for the shielded cable of the aerial incorporated in the FL1 flashing light (optional accessory), it is necessary to connect the central core and the shield as shown in figure 65.
- If you are using the flasher's aerial, remove the piece of wire (connected to the green terminal at the factory) and connect the RG58-type shielded braiding.
- The terminals **[D]** can be removed in order to facilitate the operations as shown in figure 66; make the connections and then reinsert them.

4 When the connections have been completed secure the cables using suitable clamps.

5 To close the cover, rotate it and push until you hear a click. Tighten screw **[A]**.

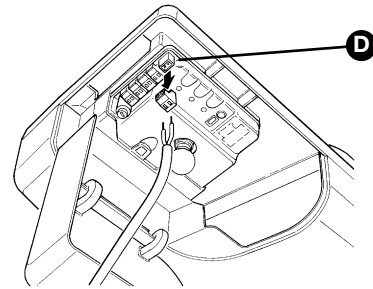

Figure 66

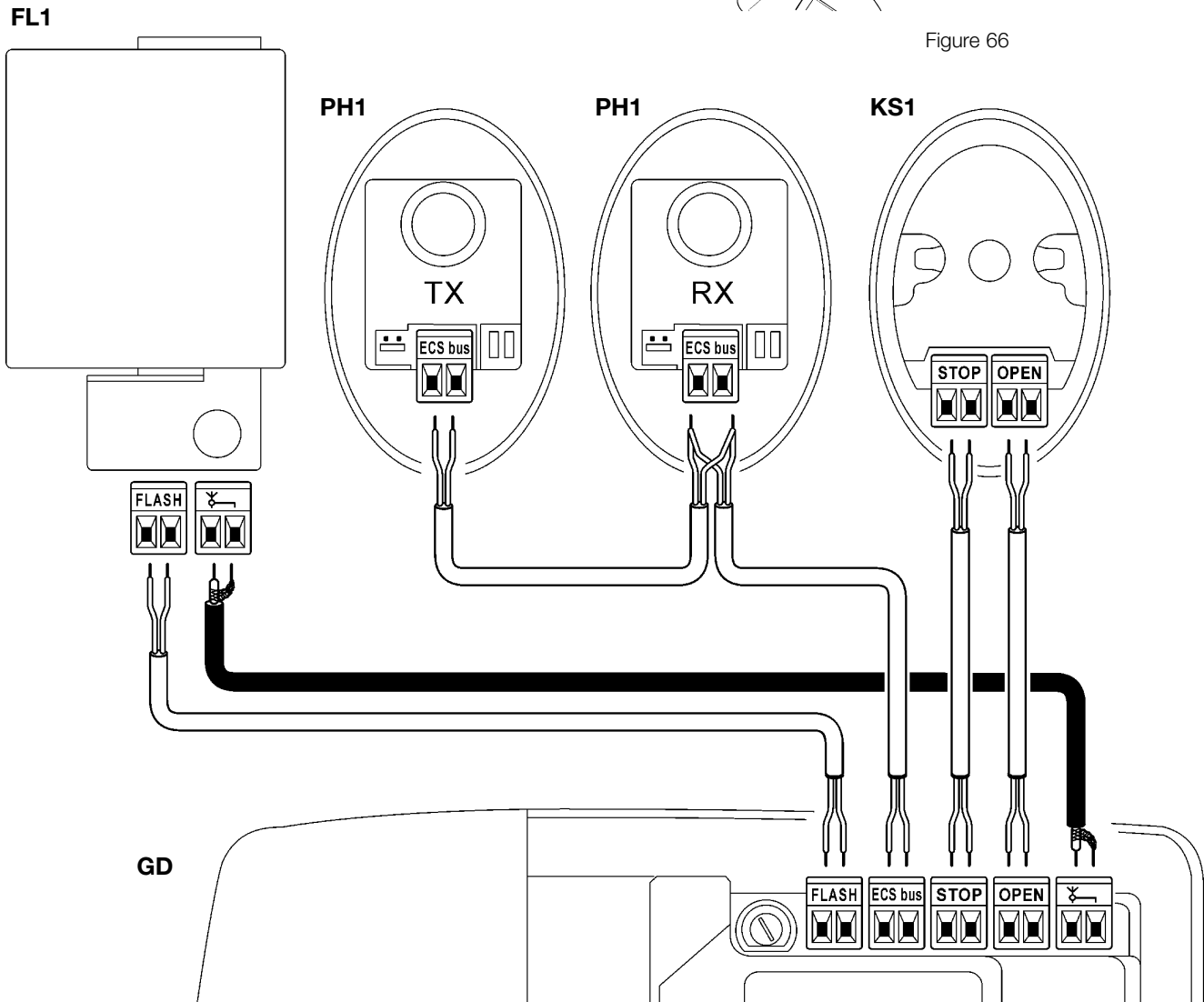

Figure 65

## 3.4 Power Supply Connection

The connection of the GD control unit to the mains must be made by a qualified electrician.



To carry out tests, insert the plug for GD in a power outlet; if necessary, use an extension cord.

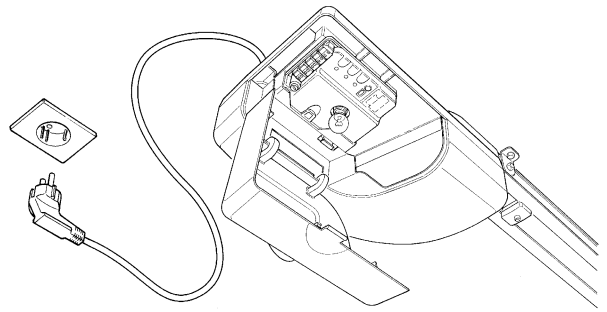

Figure 67

## 3.5 Initial checks

As soon as the control unit is energized, you should check the following:

**1** Make sure that the LED **[A]** flashes regularly, with about one flash per second.

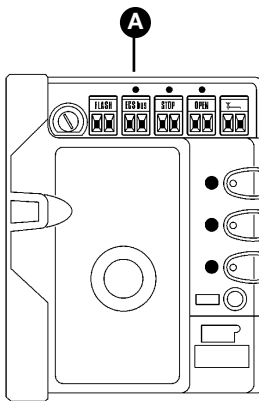

Figure 68

**2** If the system is equipped with the PH1 photocells, make sure that the SAFE LED **[B]** shown in figure 69 flashes (on both TX and RX). The type of flashing is irrelevant, it depends on other factors; what matters is that it is not always off or always on.

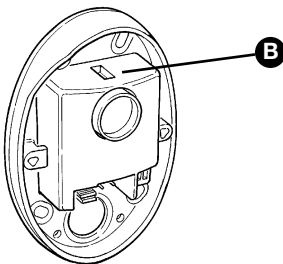

Figure 69

**3** If the system is equipped with the KS1 key-operated selector switch, make sure that the night light **[C]** is on.

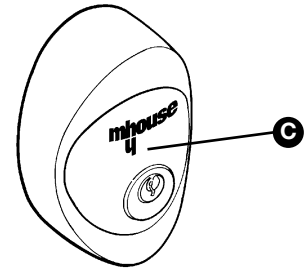

Figure 70

**4** If the above conditions are not satisfied, you should immediately switch off the power supply to the control unit and check the cable connections more carefully. For more useful information see also chapters 5.5 "Troubleshooting" and 5.6 "Diagnostics and Signals".

### 3.5.1 Recognition of Connected Devices

When you have completed the initial checks, the control unit must recognize the devices connected to it on the "ECsBus" and "STOP" terminals.

**1** On the control unit, press the P2 button **[C]** and hold it down for at least three seconds, then release the button (Figure 71).

**2** Wait a few seconds for the control unit to finish recognizing the devices.

**3** When the recognition procedure is completed, the STOP LED **[A]** must remain on, while the P2 LED **[B]** must go off. If the P2 LED flashes it means that an error has occurred: see paragraph 5.5 "Troubleshooting".

The connected devices recognition stage can be repeated again at any time, even after the installation (for example, if an additional photocell is installed); just repeat the procedure starting from step 1.

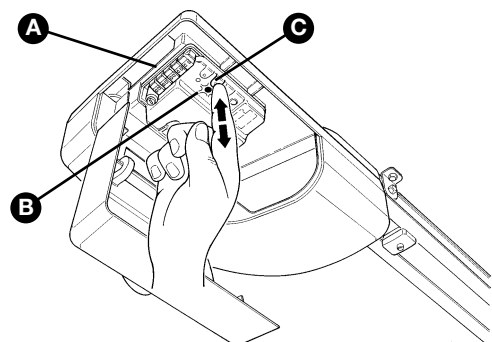

Figure 71

### 3.5.2 Learning of the door's open and closed positions

After recognizing the devices, the control unit must recognize the door's open and closed positions. During this stage, the travel of the door from the closing stop to the opening stop is detected.

- 1 Make sure that the carriage is attached.
- 2 Press key P3 **[A]** on the control unit and hold it down for at least three seconds, then release the key (Figure 72).
  - Wait until the control unit has completed the learning stage: closing, opening and re-closing of the door.
  - If any device is triggered during the learning stage, or the P3 key is pressed, the learning stage will be immediately interrupted. In this case it must be repeated from the beginning.
  - During the learning stage the courtesy light will flash just like the flashing light.
- 3 If the P3 LED **[B]** flashes at the end of the learning stage, it means that there is an error; see paragraph 5.5 "Troubleshooting".

4 Press the yellow button **[C]** in figure 73 to execute a complete opening and closing manoeuvre. During these two manoeuvres the control unit memorizes the force needed at each point along the travel. It is important that these two first manoeuvres are not interrupted by any commands.

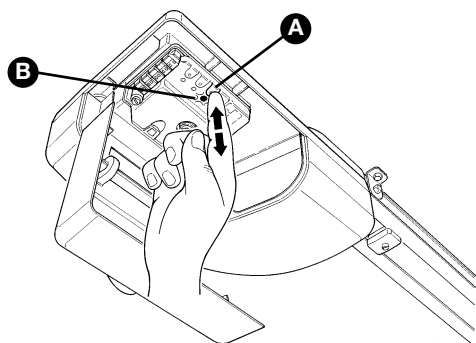

Figure 72

If the manoeuvres are not completed, repeat the learning procedure starting from step 1.

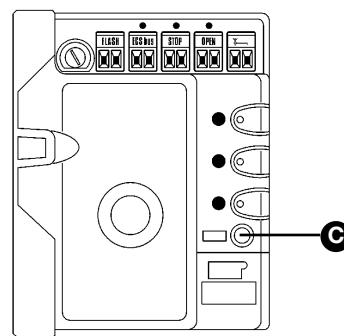

Figure 73

The position learning stage can be repeated at any time in the future (for instance, if one of the mechanical stops is moved); just repeat starting from step 1.

**WARNING: if the belt is not tightened properly, during the search for the positions it may slip on the pinion. If this happens, stop the learning procedure by pressing key P3 and stretch the belt by tightening the nut [F]. Then repeat the learning procedure starting from step 1.**

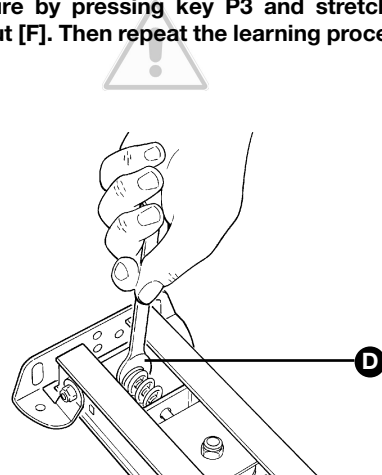

Figure 74

### 3.5.3 Testing the radio transmitter

To test the transmitter just press one of its 4 keys, make sure that the red LED flashes and that the automation carries out the related command.

The command associated to each button depends on how it has been memorized (see paragraph 5.4 "Memorization of Radio Transmitters"). The transmitter supplied has already been memorized and when you press the buttons the following commands are transmitted:

Button T1	"OPEN" command
Button T2	"Open partially" command
Button T3	"Open only" command
Button T4	"Close only" command

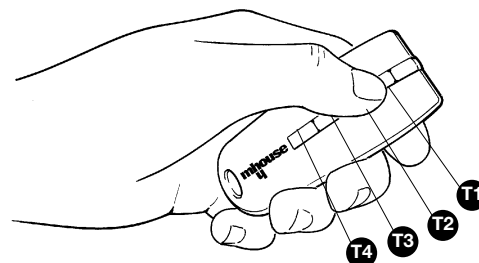

Figure 75

## 3.6 Regulations

### 3.6.1 Selecting door speed

The door can be opened and closed at two speeds: "slow" or "fast".

To switch from one speed to the other press the P2 button **[B]** momentarily; the corresponding P2 LED **[A]** will light up or go off; if the LED is off the speed is "slow", if the LED is on the speed is "fast".

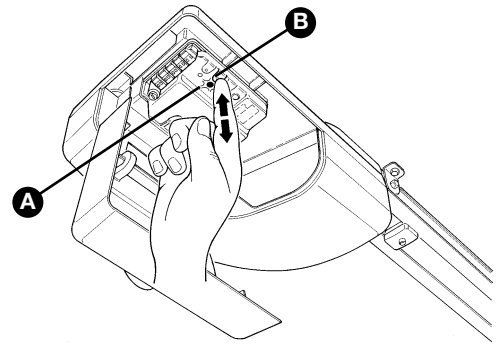

Figure 76

### 3.6.2 Selecting the type of operating cycle

The opening and closing of the door can take place according to different operating cycles:

- single cycle (semiautomatic): the door opens with a command and stays open until the next command is given, causing it to close.
- complete cycle (automatic closing): the door opens with a command and then closes automatically after a short time (for the time, see paragraph 5.1.1 "Adjusting the parameters with the radio transmitter").

To switch from one operating cycle to the other, press the P3 button **[B]** momentarily; the corresponding LED P3 **[A]** will light up or go off; if the LED is off the cycle is "single", if the LED is on the cycle is "complete".

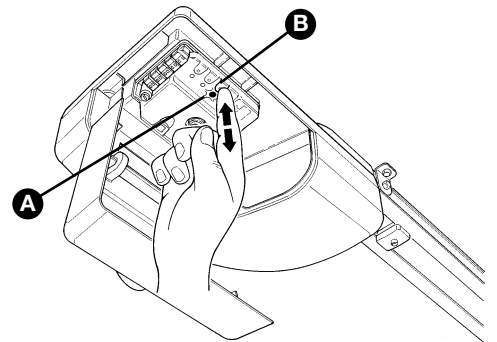

Figure 77

## 3.7 Testing and Commissioning

These are the most important operations, designed to guarantee the maximum safety and reliability of the automation system.

The testing procedure can also be used as a periodic check of the devices that make up the automation.

**The testing and commissioning operations must be performed by qualified and experienced personnel who must establish what tests should be conducted based on the risks involved, and verify the compliance of the system with applicable regulations, legislation and standards, in particular with all the provisions of EN standard 12445 which establishes the test methods for sectional and up-and-over door automation systems.**

### 3.7.1 Testing

**1 Make sure that the provisions contained in chapter 1 "WARNINGS" have been carefully observed.**

**2** Using the selector switch (if provided) or the radio transmitter, test the opening and closing of the door and make sure that the door moves in the intended direction. 

The test should be carried out a number of times to make sure that the door moves smoothly, that there are no points of excessive friction and that there are no defects in the assembly or adjustments.

**3** Check the proper operation of all the safety devices, one by one (photocells, sensitive edges, etc.). In particular, each time a device is activated the "ECSBus" LED on the control unit flashes for a longer time, confirming that the control unit recognizes the event.

**4** To check the photocells (if provided) pass a 5 cm diameter, 30 cm long cylinder on the optical axis, first near TX, then near RX and finally at the mid-point between them and make sure that in all these cases the device is triggered, switching from the active to the alarm status and vice-versa; finally, that it causes the intended action in the control unit, for example that it causes the reversal of the movement during the closing manoeuvre.

**5** The control of the correct obstacle detection is performed with the 700x300x200mm test parallelepiped with 3 black sides and 3 polished white or mirrored sides, according to the EN 12445 standard.

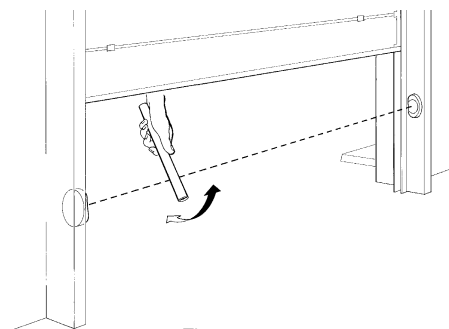

Figure 78

**6** Eseguire la misura della forza d'impatto secondo quanto previsto dalla norma EN 12445 ed eventualmente se il controllo della "forza motore" viene usato come ausilio al sistema per la riduzione della forza di impatto, provare e trovare la regolazione che dia i migliori risultati.

**7** Ensure that the entire mechanism is correctly adjusted and that the automation system inverts the manoeuvre when the door collides with a 50 mm high object on the floor.

**8** Ensure that the automation prevents or blocks the opening manoeuvre when the door is loaded with a mass of 20 Kg, fixed in the middle of the doors lower edge.

### 3.7.2 Commissioning

**The commissioning operations can be performed only after all the tests have been successfully carried out. Partial commissioning or implementation of “temporary” conditions are not permitted.**

**1** Prepare the technical documentation for the automation, which must include at least: assembly drawing (e.g. figure 1), wiring diagram (e.g. figure 65), analysis of hazards and solutions adopted, manufacturer’s declaration of conformity of all the devices installed. For GD use Annexe 1 “EC Declaration of Conformity of the GD components”

**2** Post a label on the door providing at least the following data: type of automation, name and address of manufacturer (person responsible for the “commissioning”), serial number, year of manufacture and “CE” marking.

**3** Fill out the declaration of conformity and deliver it to the owner of the automation system; for this purpose you can use Annexe 2 “EC Declaration of Conformity”

**4** Prepare the operating guide and deliver it to the owner of the automation system; Annexe 3 “OPERATING GUIDE” can be used as an example.

**5** Prepare the maintenance schedule and deliver it to the owner of the automation system; it must provide directions regarding the maintenance of all the automation devices.

**6** Post a permanent label or sign detailing the operations for the release and manual manoeuvre (use the figures in Annex 3 “Operating guide”).

**7** Before commissioning the automation system inform the owner regarding dangers and hazards that are still existing.

**8** Post a permanent label or sign with this image on the door (minimum height 60 mm) with inscription WARNING - RISK OF CRUSHING.

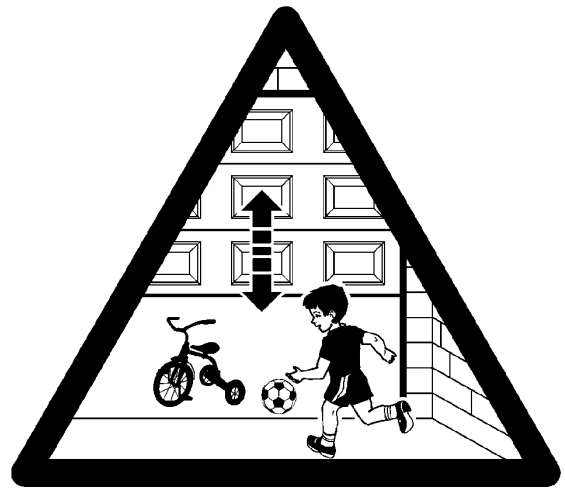

Figure 79

## 4 Maintenance

**The maintenance operations must be performed in strict compliance with the safety directions provided in this manual and according to the applicable legislation and standards.**

The devices used for the GD automation system do not require any special maintenance. However, periodically make sure (at least once every six months) that all the devices are perfectly efficient.

To this end, carry out all the tests and checks described in paragraph 3.7.1 “Testing” and the operations described in paragraph 7.3.3 “Maintenance Operations to Be Performed by the User”.

If other devices are present, follow the directions provided in the corresponding maintenance schedule.

### 4.1 Dismantling and Disposal

GD is constructed of various types of materials, some of which can be recycled (aluminium, plastic, electric cables), while others must be disposed of (electronic boards).

**WARNING: some electronic components may contain polluting substances; do not pollute the environment. Enquire about the recycling or disposal systems available for GD in compliance regulations locally in force.**

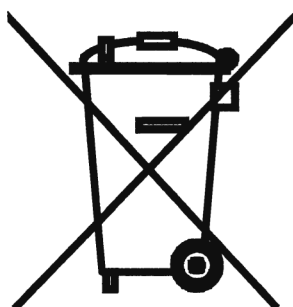

Figure 80

**1** Disconnect the system from the electrical mains by pulling the plug.

**2** Disassemble all the devices and accessories, following in reverse order the procedures described in chapter 3 “Installation”.

**3** Remove the batteries from the radio transmitters.

**4** Remove the electronic boards.

**5** Sort the various electrical and recyclable materials and consign them to licensed firms for recovery and disposal.

**6** Consign the remaining materials to authorized scrap collection centres.

## 5 Additional Information

The following chapters describe different ways of customizing GD to make it suitable for specific application requirements.

### 5.1 Advanced Adjustments

#### 5.1.1 Adjusting the Parameters with the Radio Transmitter

The radio transmitter can be used to adjust certain control unit operation parameters: there are four parameters and each of them can have four different values:

- 1) Pause time: time during which the door remains open (in the automatic closing mode).
- 2) Partial opening: partial door opening mode.

3) Motor force: maximum force beyond which the control unit recognizes an obstacle and reverses the movement.

4) "OPEN" function: sequence of movements associated to each "OPEN" command.

**Table 9**

Parameter	N°	Setting	Action: operation to be performed at point 3 in the adjustment phase
Pause time	1 <sup>st</sup>	10s	Press button T1 once
	2 <sup>nd</sup>	20s (*)	Press button T1 twice
	3 <sup>rd</sup>	40s	Press button T1 three times
	4 <sup>th</sup>	80s	Press button T1 four times
Partial opening	1 <sup>st</sup>	Opening the door 1/4 of the way	Press button T2 once
	2 <sup>nd</sup>	Opening the door half way (*)	Press button T2 twice
	3 <sup>rd</sup>	Opening the door 3/4 of the way	Press button T2 three times
	4 <sup>th</sup>	Opening the door all the way	Press button T2 four times
Motor force	1 <sup>st</sup>	Low	Press button T3 once
	2 <sup>nd</sup>	Medium-low (*)	Press button T3 twice
	3 <sup>rd</sup>	Medium-high	Press button T3 three times
	4 <sup>th</sup>	High	Press button T3 four times
"OPEN" function	1 <sup>st</sup>	"Open"- "Stop"- "Close"- "Stop"	Press button T4 once
	2 <sup>nd</sup>	"Open"- "Stop"- "Close"- "Open" (*)	Press button T4 twice
	3 <sup>rd</sup>	"Open"- "Close"- "Open"- "close"	Press button T4 three times
	4 <sup>th</sup>	"Open"- "Open"- "Open" (opening only)	Press button T4 four times

(\*) Original factory setting

The parameter adjustment operation can be performed using a radio transmitter, provided it is memorized in mode 1 like the one supplied.

If no transmitter memorized in Mode 1 is available, you can memorize one just for this phase and delete it immediately afterwards (see paragraph 5.4.1 "Mode 1 memorization" and paragraph 5.4.4 "Deleting a radio transmitter").

**WARNING:** when using the transmitter to make adjustments you need to give the control unit time to recognize the radio command; this means that the buttons must be pressed and released slowly, held down for at least one second, then released for one second and so on.

1 Press buttons T1 and T2 on the radio transmitter simultaneously for at least 5s.

2 Release the two buttons.

3 Within 3 seconds, perform the action described in Table 9 based on the parameter to be modified

**Example:** to set the pause time at 40 s.

- 1<sup>st</sup> Press buttons T1 and T2 and hold them down for at least 5s
- 2<sup>nd</sup> Release T1 and T2
- 3<sup>th</sup> Press button T1 three times

All the parameters can be adjusted as required without any contraindication; only the adjustment of the "motor force" requires special care:

- Do not use high force values to compensate for points of abnormal friction on the door. Excessive force can compromise the operation of the safety system or damage the door.
- If the "motor force" control is used to assist the impact force reduction system, measure the force again after each adjustment in compliance with EN standard 12445.
- The weather conditions may affect the movement of the door, therefore periodic re-adjustments may be necessary.

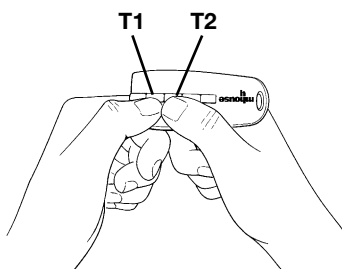

Figure 81

## 5.1.2 Checking the Adjustments with the Radio Transmitter

With a radio transmitter memorized in Mode 1 you can check the values set for each parameter at any time by following the sequence described below:

- 1 Press buttons T1 and T2 on the radio transmitter simultaneously for at least 5s.
- 2 Release the two buttons.
- 3 Within 3 seconds, perform the action described in Table 9 based on the parameter to be checked
- 4 Release the button when the flashing light starts flashing
- 5 Count the flashes and, based on their number, check the corresponding value in table 8.

**Table 10**

Parameter	Action
Pause time	Press button T1 and hold it down
Pedestrian gate	Press button T2 and hold it down
Motor force	Press button T3 and hold it down
“OPEN” function	Press button T4 and hold it down

**Example:** If the flashing light flashes three times after you have pressed T1 and T2 for 5s and then button T1, the pause time is set at 40s.

## 5.2 Optional Accessories

In addition to the devices featured in GD, other ones are available as optional accessories designed to enhance the automation system and improve its safety and performances.

**PT50:** Pair of 500 mm posts with one photocell on each.

**PT100:** (For GD10 only) Pair of 1000 mm high posts with two photocells.

**PR1:** (For GD10 only) 24V buffer battery for power supply in the event of power failure. It guarantees at least 10 complete cycles.

**GA1 OSCILLATING ARM:** accessory that enables the system to open up-and-over-type doors

**GU1 MANUAL RELEASE KIT:** accessory that enables the manual opening of the door even in the event of power failures.

For information on the new accessories, refer to the MHOUSE catalogue or visit the site [www.mhouse.biz](http://www.mhouse.biz).

## 5.3 Adding or Removing Devices

Devices can be added to or removed from the GD automation system at any time.

**Do not add any devices until you have made sure that they are perfectly compatible with GD; for further information contact MHOUSE Customer Service.**



### 5.3.1 ECSBus

ECSBus is a system that allows you to connect the ECSBus devices using only two wires which carry both the power supply and the communication signals. All the devices are connected in parallel on the 2 wires of the ECSBus itself; each device is individually recognized because a univocal address is assigned to it during the installation.

The photocells, as well as other devices that adopt this system, can be connected to ECSBus, such as safety devices, control buttons, signalling lights etc. For information on the ECSBus devices, refer to the MHOUSE catalogue or visit the site [www.mhouse.biz](http://www.mhouse.biz).

The control unit recognizes all the connected devices individually through a suitable recognition process, and can detect all the possible abnormalities with absolute precision. For this reason, each time a device connected to ECSBus is added or removed the control unit must go through the recognition process; see paragraph 5.3.3 “Recognition of Other Devices”).

### 5.3.2 STOP Input

STOP is the input that causes the immediate interruption of the manoeuvre (with a short reverse run). Devices with output featuring normally open “NO” contacts (like the KS1 selector switch) and devices with normally closed “NC” contacts, as well as devices with 8.2K $\Omega$  constant resistance output, like sensitive edges, can be connected to this input. Multiple devices, even of different type, can be connected to the STOP input if suitable arrangements are made.

To do this, proceed as described in the following table:

**Table 11**

		1 <sup>st</sup> device type:		
		NA	NC	8,2k $\Omega$
2 <sup>nd</sup> device type:	NA	In parallel (note 2)	(note 1)	In parallel
	NC	(note 1)	In series (note 3)	In series
	8,2k $\Omega$	In parallel	In series	In parallel (note 4)

Note 1. The NO and NC combination can be obtained by placing the two contacts in parallel, and placing in series to the NC contact an 8.2K $\Omega$

resistance (therefore, the combination of 3 devices is also possible: NO, NC and 8.2K $\Omega$ ).

Note 2. Any number of NO devices can be connected to each other in parallel.

Note 3. Any number of NC devices can be connected to each other in series.

Note 4. Only two devices with 8.2K $\Omega$  constant resistance output can be connected in parallel; if needed, multiple devices must be connected “in cascade” with a single 8.2K $\Omega$  termination resistance.

**Warning: if the STOP input is used to connect devices with safety functions, only the devices with 8.2K $\Omega$  constant resistance output guarantee the fail-safe category 3.**

During the recognition stage the control unit, like ECSBus, recognizes the type of device connected to the STOP input; subsequently it commands a STOP whenever a change occurs in the recognized status.

### 5.3.3 Recognition of Other Devices

Normally the recognition of the devices connected to the ECSBus and the STOP input takes place during the installation stage. However, if new devices are added or old ones removed, the recognition process can be gone through again by proceeding as follows:

- 1 On the control unit, press the P2 **[B]** button and hold it down for at least five seconds, then release it.
- 2 Wait a few seconds for the control unit to finish recognizing the devices
- 3 When the recognition stage is completed the P2 LED **[A]** should go off. If the P2 LED flashes it means that an error has occurred: see paragraph 5.5 "Troubleshooting".
- 4 After you have added or removed any devices, the automation system must be tested again according to the directions contained in paragraph 3.7.1 "Testing".

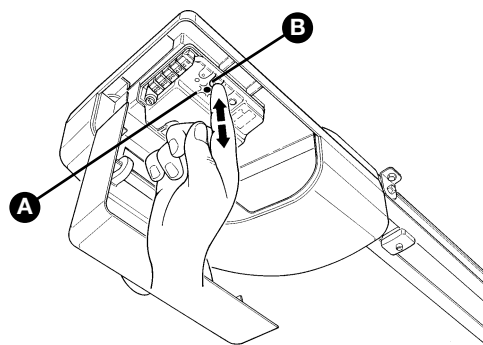

Figure 82

### 5.3.4 Addition of Optional Photocells

You can install a pair of photocells (not supplied with GD) at any time. To ensure the correct recognition of the photocells by the control unit, the former must be assigned addresses by means of jumpers. The address allocation procedure must be performed on TX as well as RX (arranging the jumpers in the same manner).

Make sure there are no other photocell pairs with the same address. The photocells need to be assigned addresses to make sure that they are correctly recognized among the other ECSBus devices, and in order to assign the performed function.

The photocell of a sectional door automation system can be installed following that shown in fig. 83. Refer to Fig. 84 for up-and-over door automation systems.

Photo E and Photo F are used in installations that require the complete protection of the automation system, also in opening.

The recognition phase must be performed after installation or the removal of photocells as described in paragraph "5.3.3 Recognition of Other Devices".

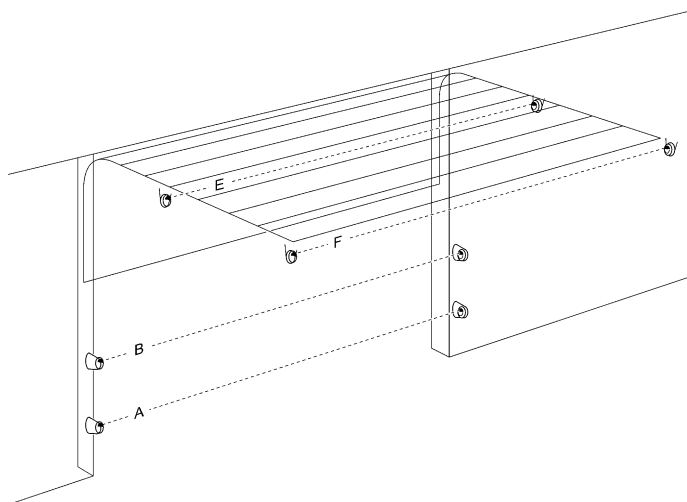

Figure 83

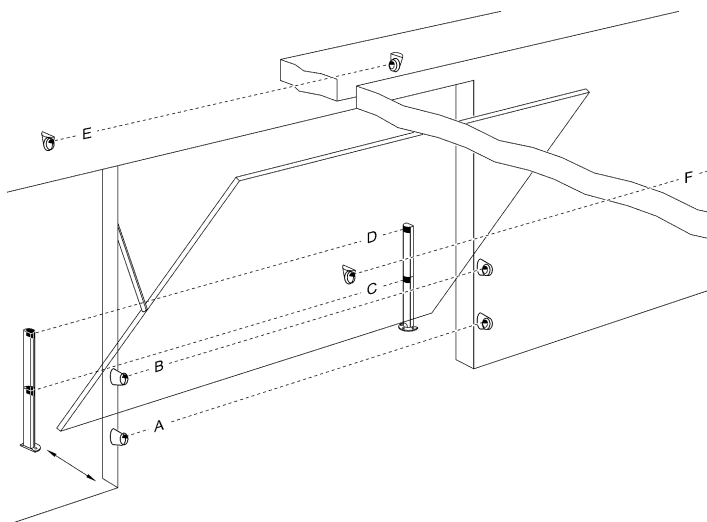

Figure 84

Table 12

Photocell	Jumpers	Photocell	Jumpers
<b>A</b> Internal photocell h= 50 cm; activated when closing		<b>E</b> External photocell activated when opening	
<b>B</b> Internal photocell h= 100 cm; activated when closing		<b>F</b> Internal photocell activated when opening	
<b>C</b> External photocell h= 50 cm; activated when closing and opening		<b>G</b> INADMISSIBLE CONFIGURATION	
<b>D</b> External photocell h= 100 cm; activated when closing and opening			

**WARNING:** in the GD1 version the ECSBus output has a maximum load of 1 unit (with A type addresses only)  
in the GD10 version it has a maximum load of 6 units;  
a pair of photocells absorbs power equal to 1 ECSBUS unit



## 5.4 Memorization of Radio Transmitters

The control unit contains a radio receiver for TX4 transmitters; the one included in the package is pre-memorized and operative.

If you wish to memorize a new radio transmitter you have two choices:

- Mode 1: in this “mode” the radio transmitter is used to its fullest extent, i.e. all the buttons execute a pre-established command (the transmitter supplied with GD is memorized in Mode 1). It is obvious that in Mode 1 a radio transmitter can be used to command a single automation, i.e.:

T1 button	“OPEN” command
T2 button	“Partial opening” command
T3 button	“Open only” command
T4 button	“Close only” command

- Mode 2: one of the four commands available can be associated to each button. This mode, used properly, allows you to command 2 or more different automations; for example:

T1 button	“Open only” command automation N° 1
T2 button	“Close only” command automation N° 1
T3 button	“OPEN” command automation N° 2
T4 button	“OPEN” command automation N° 3

Each transmitter is, of course, a separate unit, and while some are memorized in mode 1 others can be memorized in mode 2 on the control unit.

The overall memory capacity is 150 units; memorization in mode 1 takes up one unit for each transmitter while mode 2 takes up one unit for each button.

**Warning: since the memorization procedures are timed (10s), you must read the instructions in the following paragraphs before you proceed with their execution.**

### 5.4.1 Memorization Mode 1

- 1 Press button P1 **[B]** for at least 3s.

When the P1 LED **[A]** goes off, release the button.

- 2 Within 10s, press any button on the radio transmitter to be memorized and hold it down for at least 3s

If the memorization procedure is successful, the “P1” LED will flash 3 times.

- 3 If there are other transmitters to be memorized, repeat step 2 within the next 10s, otherwise the memorization stage will terminate automatically.

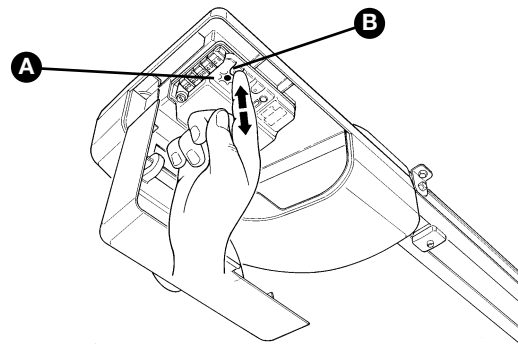

Figure 85

### 5.4.2 Memorization Mode 2

With the memorization in mode 2 of the radio transmitter, any one of the four commands (“OPEN”, “Open partially”, “Open only” and “Close only”) can be associated to each button.

In Mode 2 each button requires a separate memorization stage.

- 1 Press button P1 (figure 85) on the control unit as many times as the number corresponding to the desired command, according to the following table:

1 time	“OPEN” command
2 times	“open partially” command
3 times	“Open only” command
4 times	“Close only” command

- 2 Make sure that the P1 LED makes as many quick flashes as the number corresponding to the selected command.

- 3 Within 10 s, press the desired button on the radio transmitter to be memorized, and hold it down for at least 2 s.

If the memorization procedure is successful, the “P1” LED will flash 3 times slowly.

- 4 If there are other transmitters to be memorized for the same type of command, repeat step 3 within the next 10s, otherwise the memorization stage will terminate automatically.

### 5.4.3 Remote memorization

A new radio transmitter can be memorized in the control unit without directly operating the buttons on it. You need to have an “OLD” pre-memorized operational radio transmitter. The “NEW” radio transmitter to be memorized will inherit the characteristics of the OLD one, i.e. if the OLD radio transmitter was memorized in Mode 1, the NEW one will also be memorized in Mode 1. In this case, during the memorization stage you can press any key on the two transmitters. If, on the other hand, the OLD transmitter was memorized in Mode 2 you must press the button on the OLD transmitter which corresponds to the desired command, and the button on the NEW transmitter to which you wish to associate that command.

Holding the two transmitters, position yourself within the operating range of the automation and perform the following operations:

- 1 Press the button on the NEW radio transmitter and hold it down for at least 5s, then release it.
- 2 Press the button on the OLD radio transmitter 3 times slowly.
- 3 Press the button on the NEW radio transmitter once slowly.

At this point the NEW radio transmitter will be recognized by the control unit and will assume the characteristics of the OLD one.

If there are other transmitters to be memorized, repeat all the steps above for each new transmitter.

## 5.4.4 Deleting a Radio Transmitter

Only if the system features a radio transmitter, you can delete it from the memory by proceeding as follows.

If the transmitter is memorized in Mode 1, only one deletion procedure will be needed and at step 3 you can press any button. If the transmitter is memorized in Mode 2, one deletion procedure will be needed for each key memorized

- 1 Press the P1 button **[B]** (figure 86) on the control unit and hold it down.
- 2 Wait until the P1 LED **[A]** lights up, then, within three seconds:

3 Press the key on the radio transmitter to be deleted and hold it down for at least three seconds. If the deletion procedure is successful, the P1 LED will flash rapidly five times. If the P1 LED flashes only once slowly, it means that the deletion procedure has not been successful because the transmitter is not memorized.

4 If there are other transmitters to be deleted, press the P1 key and repeat step 3 within ten seconds, otherwise the deletion procedure will be terminated automatically.

## 5.4.5 Deleting all the Radio Transmitters

With this operation all the memorized transmitters are deleted.

- 1 Press the P1 button **[B]** on the control unit and hold it down.
- 2 Wait until the P1 LED **[A]** lights up, then wait until it goes off, then wait until it has flashed 3 times.
- 3 Release the P1 button precisely upon the third flash.
- 4 Wait approximately 4 s for the deletion process to be completed; during this time the LED will flash very quickly.

If the procedure is successful, after a few moments the "P1" LED will flash slowly 5 times.

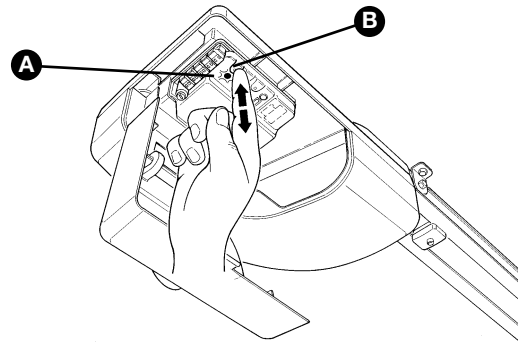

Figure 86

## 5.5 Troubleshooting

The following table contains instructions to help you solve malfunctions or errors that may occur during the installation stage or in case of failure.

Table 13

Symptoms	Probable cause and possible solution
The radio transmitter does not emit any signal (the LED <b>[A]</b> does not light up)	<ul style="list-style-type: none"> <li>• Check to see if the batteries are exhausted, if necessary replace them (paragraph 7.3.4 "Replacing the Remote Control Battery").</li> </ul>
The manoeuvre does not start and the "ECSBus" LED <b>[B]</b> does not flash	<ul style="list-style-type: none"> <li>• Make sure that the power cord is properly plugged into the mains outlet</li> <li>• Check to see if the fuses <b>[E]</b> or <b>[F]</b> are blown; if necessary, identify the reason for the failure and then replace the fuses with others having the same current rating and characteristics.</li> </ul>
The manoeuvre does not start and the courtesy light <b>[G]</b> is off.	<ul style="list-style-type: none"> <li>• Make sure that the command is actually received. If the command reaches the OPEN input, the corresponding "OPEN" LED <b>[D]</b> must light up; if you are using the radio transmitter, the "ECSBus" LED must make two long flashes</li> </ul>
The manoeuvre does not start and the courtesy light flashes a few times.	<ul style="list-style-type: none"> <li>• Make sure that the STOP input is active, i.e. that the "STOP" LED <b>[C]</b> comes on. If this does not happen, check the devices connected to the STOP input.</li> <li>• The photocell test which is performed at the starting of each manoeuvre is not successful; check the photocells, also according to Table 12 (Paragraph 5.6.1 "Photocells").</li> </ul>
The manoeuvre starts but it is immediately followed by a reverse run	<ul style="list-style-type: none"> <li>• The selected force is too low to move the door. Check to see whether there are any obstacles; if necessary increase the force as described in chapter 5.1 "Advanced adjustments"</li> </ul>
The manoeuvre is carried out but the flashing light does not work	<ul style="list-style-type: none"> <li>• Make sure that there is voltage on the flashing light's FLASH terminal during the manoeuvre (being intermittent, the voltage value is not important: approximately 10-30Vac); if there is voltage, the problem is due to the lamp; in this case replace the lamp with one having the same characteristics.</li> </ul>
The manoeuvre is carried out but the courtesy light does not work.	<ul style="list-style-type: none"> <li>• Replace the lamp with one having the same characteristics.</li> </ul>

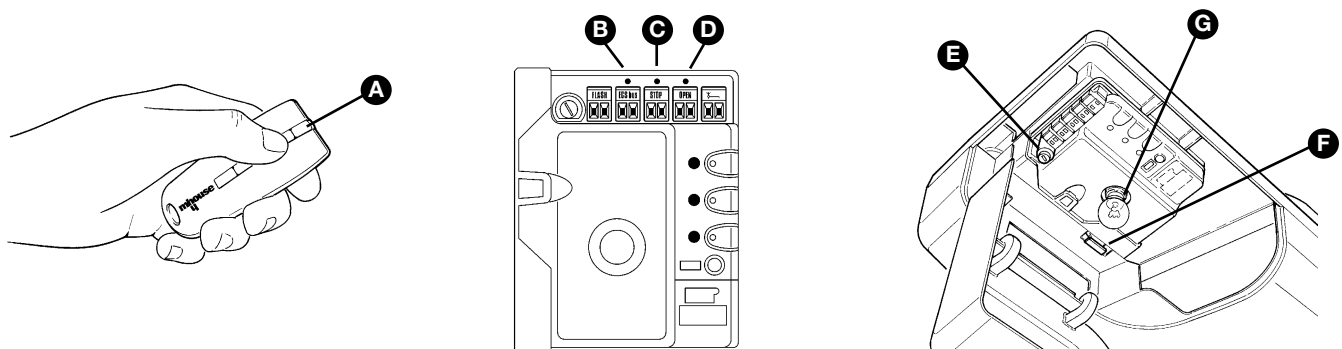

Figure 87

## 5.6 Diagnostics and Signals

A few devices issue special signals that allow you to recognize the operating status or possible malfunctions.

### 5.6.1 Photocells

The photocells are equipped with a "SAFE" LED **[A]** (Figure 88) that allows you to check the operating status at any time.

**Table 14**

LED "SAFE"	Status	Action
Off	The photocell is not powered or is faulty	Make sure that there is voltage (approx. 8-12 Vdc) on the photocell's terminals; if the voltage is correct, the photocell is probably faulty.
3 quick flashes and a second's pause	Device not recognized by the control unit	Repeat the recognition procedure on the control unit. Make sure that all the photocell pairs on ECSBus have correct addresses
1 very slow flash	The RX receives a perfect signal	Normal operation
1 slow flash	The RX receives a fair signal	Normal operation
1 quick flash	The RX receives a poor signal	Normal operation but you should check the TX-RX alignment and make sure the glasses are clean
1 very quick flash	he RX receives a very poor signal	It is at the limit of normal operation, you should check the TX-RX alignment and make sure the glasses are clean
Always on	The RX does not receive any signal	Check to see if there is an obstacle between TX and RX. Make sure that the LED on TX flashes once slowly. Check the TX-RX alignment

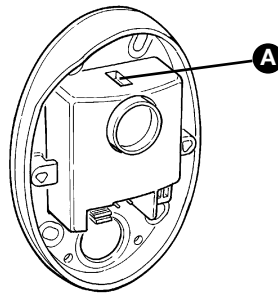

Figure 88

### 5.6.2 Flashing and courtesy lights

During the manoeuvre the flashing light flashes once every second, while the courtesy light is always on; when something is wrong the flashes are more frequent (half a second); the light flashes twice with a second's pause between flashes. The diagnostic flashing itself is signalled by the courtesy light.

**Table 15**

Quick flashes	Status	Action
1 flash 1 second's pause 1 flash	ECSBus error	At the starting of the manoeuvre, the devices present do not correspond to those recognized; check and if necessary try repeating the recognition process (see 5.3.3 "Recognition of Other Devices"). One or more devices may be faulty; check and, if necessary, replace them.
2 flashes 1 second's pause 2 flashes	Triggering of a photocell	At the starting of the manoeuvre, one or more photocells do not enable it; check to see if there are any obstacles. If there is an obstacle impeding the movement no action is required.
3 flashes 1 second's pause 3 flashes	Activation of the "motor force" limiting device	During the movement, the door experienced excessive friction; identify the cause
4 flashes 1 second's pause 4 flashes	Activation of the STOP input	During the movement the STOP input was activated; identify the cause

### 5.6.3 Control Unit

On the control unit there is a set of LED's each of which can give special indications both during normal operation and in case of malfunctions.

**Table 16**

LED ECSBus [A]	Status	Action
Off	Malfunction	Make sure there is power supply; check to see if there are blown fuses; identify the cause of the malfunction and then replace blown fuses with others having the same characteristics
On	Serious malfunction	There is a serious malfunction; try switching off the control unit for a few seconds; if the condition persists it means there is a malfunction and the electronic board has to be replaced
One flash every second	Everything OK	Normal operation of control unit
2 long flashes	The status of the inputs has changed	This is normal when there is a change in one of the inputs: OPEN, STOP, triggering of photocells or the radio transmitter is used
Series of flashes separated by a pause	It corresponds to the flashing and courtesy light's signal. (See Table 14)	
LED STOP [B]	Status	Action
Off	Cutting in of the STOP input	Check the devices connected to the STOP input
On	Everything OK	STOP input active
LED OPEN [C]	Status	Action
Off	Everything OK	OPEN input not active
On	Cutting in of the OPEN input	This is normal only if the device connected to the OPEN input is actually active
LED P1 [D]	Status	Action
Off	Everything OK	No memorization in progress
On	Memorization in Mode 1	This is normal during memorization in mode 1 which lasts maximum 10s
Series of quick flashes, from 1 to 4	Memorization in Mode 2	This is normal during memorization in mode 2 which lasts maximum 10s
LED P2 [E]	Status	Action
Off	Everything OK	"Slow" speed selected
On	Everything OK	"Fast" speed selected
1 flash every second	No device has been memorized or an error has occurred during the recognition process	There may be faulty devices; check and, if necessary, try repeating the recognition process (see paragraph 3.5.1 "Recognition of Connected Devices")
2 flashes per second	Device recognition stage in progress	It indicates that the search for the connected devices is under way (this stage lasts a few seconds at the most)
LED P3 [F]	Status	Action
Off	Everything OK	Cyclic operation
On	Everything OK	Complete cyclic operation
1 flash every second	the positions have not been acquired.	Repeat the procedure (see paragraph 3.5.2. "learning the door's open and closed positions")
2 flashes every second	position learning procedure in progress	

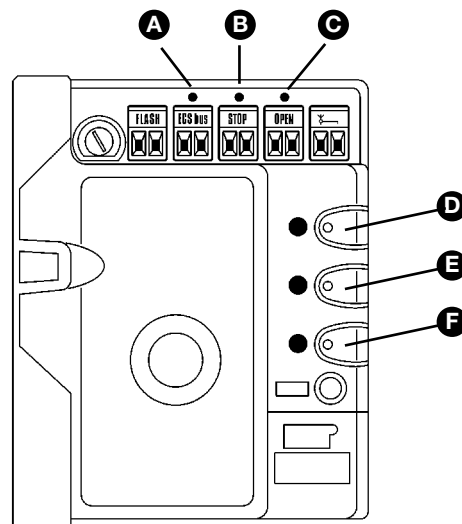

Figure 89

## 6 Technical characteristics

GD is produced by NICE S.p.a. (TV) I, MHOUSE S.r.l. is an affiliate of the NICE S.p.a. group.

Nice S.p.a., in order to improve its products, reserves the right to modify their technical characteristics at any time without prior notice. In any case, the manufacturer guarantees their functionality and fitness for the intended purposes.

Note: all the technical characteristics refer to a temperature of 20°C.

Technical characteristics		
Model type	GD1K	GD10K
Type	Electromechanical gearmotor for automated sectional and up-and-over doors incorporating a control unit complete with radio receiver for "TX4" transmitters.	
Adopted technology	24Vdc motor, helical teeth reduction gear; drive guide with timing belt and mechanical release A transformer inside the motor but separated from the control unit reduces mains voltage to the nominal voltage of 24Vdc used by the automation system	
Peak thrust [corresponds to the force necessary to move a leaf]	10.8Nm [600N]	18Nm [1000N]
Nominal torque [corresponds to the force necessary to keep a leaf moving]	5.4Nm [300Nm]	9Nm [500Nm]
Idling speed	0.10 m/s in "slow" speed mode; 0.18 m/s in "fast" speed mode	0.10 m/s in "slow" speed mode; 0.15 m/s in "fast" speed mode
Velocità alla coppia nominale	0.05m/s in velocità "lenta" 0.09m/s in velocità "veloce"	0.05m/s in velocità "lenta" 0.08m/s in velocità "veloce"
Maximum frequency of cycles	50 complete cycles per day (For a maximum of approx. 10 cycles per hour. A maximum of 5 cycles per hour is permitted at 50°C.)	
Maximum continuous cycle time	approx. 4 minutes (the control unit limits the continuous operation)	
Working Limits	Its structural characteristics make it suitable for use on sectional and up-and-over doors with counterweights that are within the dimensions and limits indicated in table 7.	
Power supply GD Power supply GD/V1	230Vac (±10%) 50/60Hz 120Vac (±10%) 50/60Hz	
Max. absorbed power	250W	370W
Insulation class	1 (a safety grounding system is required)	
Emergency power supply	---	with PR1 accessory
Flashing light output	For visual signalling devices with 12V lamp, maximum 21W	
Courtesy light	12V lamp maximum 21 W BA15 socket (automotive type lamp), stays on 60s after the manoeuvre	
ECSBus output	One output with a maximum load of 1 ECSBus unit	One output with a maximum load of 6 ECSBus unit
"OPEN" input	For normally open contacts (the closing of the contact causes the "OPEN" command)	
STOP input	For normally open contacts and/or for 8,2KΩ, constant resistance, or normally closed contacts with recognition of the "normal" status (any variation from the memorized status causes the "STOP" command)	
Radio aerial input	52Ω for RG58 or similar type of cable	
Maximum cable length	Mains power supply: 30m; inputs/outputs: 20m with aerial cable preferably shorter than 5m (observe the directions regarding the minimum gauge and type of cable)	
Remote control possibility	With TX4 transmitters the control unit can receive one or more of the following commands: "OPEN", "Open partially", "Open only" and "Close only"	
TX4 transmitters memorized	Up to 150 if memorized in mode 1	
Range of TX4 transmitters	From 10 to 50 m without aerial, from 50 to 100 m with aerial incorporated in the FL1 flashing light. The range can vary if there are obstacles or electromagnetic disturbances, and is affected by the position of the receiving aerial incorporated in the flashing light.	
Programmable functions	"Cycle" or "Complete cycle" operation (automatic closing) "Slow" or "fast" motor speed The pause time in the "complete cycle" mode can be set at 10, 20, 40, 80 seconds The type of pedestrian opening can be selected from 4 modes The sensitivity of the obstacle detection system can be selected from 4 levels The operation of the "Open" command can be selected from 4 modes	
Self-programmed functions	Automatic detection of devices connected to the ECSBus Output Automatic detection of the type of "STOP" device (NO or NC contact or 8,2KΩ resistance) Automatic detection of door length and calculation of deceleration points	
Operating ambient temperature	-20 ÷ 50°C	
Not suitable for use in acid, saline or potentially explosive atmosphere	No	
Mounting	Horizontal	
Protection class	IP40	
Dimensions / weight	380 x 280 x h 110mm / 4kg	380 x 280 x h 110mm / 5kg

<b>PH1 Photocells (optional)</b>	
Type	Presence detector for automated gates and doors (type D according to EN standard 12453) consisting of a "TX" transmitter and an "RX" receiver
Adopted technology	Optical, by means of direct TX-RX interpolation with modulated infrared ray
Detection capacity	Opaque objects located on the optical axis between TX and RX, larger than 50mm and moving slower than 1.6m/s
TX transmission angle	approx. 20°
RX reception angle	approx. 20°
Useful capacity	Up to 10m for maximum TX-RX misalignment of ± 5° (the device can signal an obstacle even in the case of adverse weather conditions)
Power supply/output	The device can be connected only to "ECSSBus" networks from which it receives the power supply and sends the output signals.
Absorbed power	1 ECSSBus unit
Maximum cable length	Up to 20 m (observe the directions regarding the minimum gauge and type of cable)
Addressing possibility	Up to 7 detectors with protection function and 2 with opening command function. The automatic synchronism prevents any interference among the various detectors
Operating ambient temperature	-20 ÷ 50°C
Use in acid, saline or potentially explosive atmosphere	No
Mounting	Vertical, wall-mounted
Protection class	IP44
Dimensions / weight (TX and RX)	95 x 65 h 25mm / 65g

<b>KS1 Key-Operated Selector Switch (optional)</b>	
Type	Key-operated double switch suitable for control of automatic gates and doors. Illuminated for night operation.
Adopted technology	Activation protected by a lock, the insertion and clockwise turning of the key causes the closing of a contact, the counter-clockwise turning of the key causes the closing of the second contact; spring-loaded for return of key to the middle position.
Tamper-proof	The selector switch can be opened to access the connections only by inserting the key and turning it in either direction
Security lock	Key with 450 different key
Power supply/contacts	The device can only be connected to the "OPEN" and "STOP" terminals on the MHOUSE automation control units, to which it sends the control signals and by which it is energized for night illumination
Operating ambient temperature	-20 ÷ 50°C
Use in acid, saline or potentially explosive atmosphere	No
Mounting	Vertical, wall-mounted
Protection class	IP44
Dimensions / weight	95 x 65 h 36mm / 135g

<b>FL1 Flashing light (optional)</b>	
Type	Flashing signalling light for automatic gates and doors. The device incorporates a receiving aerial for remote control
Adopted technology	Visual signalling device with 12V 21W lamp, controlled by MHOUSE automation control units
Lamp	12V 21W BA15 socket (automotive type lamp)
Power supply	The device can be connected only to the "FLASH" and "AERIAL" terminals on the MHOUSE automatic gate control units
Operating ambient temperature	-20 ÷ 50°C
Use in acid, saline or potentially explosive atmosphere	No
Mounting	Horizontal surface-mounted or vertical wall-mounted
Protection class	IP44
Dimensions / weight	120 x 60 h 170mm / 285g

**TX4 transmitters**

Type	Radio transmitters for remote control of automatic sectional and up-and-over doors
Adopted technology	AM OOK coded modulation of radio carrier
Frequency	433.92 Mhz
Coding	Rolling code with 64 Bit code (18 billion million combinations)
Buttons	4, each button sends a command and can be used for the different controls of the same control unit or to control different control units.
Irradiated power	approx. 0,0001W
Power supply	6V +20% -40% with two CR2016 type lithium batteries
Battery life	3 years, estimated on the basis of 10 commands/day, each lasting 1s at 20°C (at low temperatures the efficiency of the batteries decreases)
Operating ambient temperature	-20 ÷ 50°C
Use in acid, saline or potentially explosive atmosphere	No
Protection class	IP40 (suitable for use indoors or in protected environments)
Dimensions / weight	72 x 31 h 11mm / 18g

## 7 Annexes

The following annexes are designed to help you prepare the technical documentation

### 7.1 Annexe 1: CE Declaration of Conformity of GD Components

CE Declaration of Conformity of GD components; this statement must be attached to the technical documentation.

### 7.2 Annexe 2: CE Declaration of Conformity of Power Operated Sectional or Up-and-over Door

CE Declaration of Conformity to be filled in and delivered to the owner of the power operated Sectional or Up-and-over Door.

### 7.3 Annexe 3: Operating Guide

Brief guide to be used as an example for drafting the operating guide to be delivered to the owner of the power operated sectional or up-and-over door.



# Declaration of Conformity

CE Declaration of Conformity according to the directives 98/37/CE, 73/23/CEE, 89/336/CEE and 1999/5/CEGD1 and GD10 are produced by NICE S.p.a. (TV) I, MHOUSE S.r.l. is an affiliate of the NICE S.p.a. group.

Number: 171/GD1/GB      Date: 02/02/2005      Revision: 01

The undersigned Lauro Buoro, managing director, declares under his sole responsibility that the following product:

Manufacturer's name: NICE S.p.a.  
Address: Via Pezza Alta 13, 31046 Z.I. Rustignè, Oderzo (TV) Italia  
Type: Electromechanical gearmotor with incorporated control unit and radio receiver  
Model: GD1, GD10  
Accessories: TX4, PH1, KS1, FL1

Satisfies the essential requirements of the following Directives:

Reference	Heading
98/37/CE (modified 89/392/EEC)	DIRECTIVE 98/37/EC OF THE EUROPEAN PARLIAMENT AND OF THE COUNCIL of June 22, 1998, for the harmonisation of the legislations of member States regarding machines.
According to Annexe II, part B (EC declaration of conformity by the manufacturer)	

As specified in the 98/37EC directive, the use of this product is not admitted until the machine, on which this product is mounted, has been identified and declared as conforming to the directive 98/37/CE.

Satisfies the essential requirements of the following Directives, as amended by the directive 93/68/EEC of the European Council of 22nd July 1993:

Reference	Heading
73/23/EEC	DIRECTIVE 73/23/EEC OF THE EUROPEAN COUNCIL of 19th February 1973 for the harmonization of the legislation of member States regarding electrical equipment designed to be used within certain voltage limits.
According to the following harmonised standards: EN 60335-1; EN 60335-2-95.	
89/336/EEC	DIRECTIVE 89/336/EEC OF THE EUROPEAN COUNCIL of 3rd May 1989, for the harmonization of the legislations of member States regarding electromagnetic compatibility.
According to the following harmonised standards: EN 61000-6-2; EN 61000-6-3.	

Furthermore, the product complies with the essential requisites specified in article 3 of the following EC directive, for the use the products have been manufactured for:

Reference	Heading
1999/5/EC	DIRECTIVE 1999/5/EC OF THE EUROPEAN PARLIAMENT AND OF THE COUNCIL of 9th March 1999 concerning radio equipment and telecommunications terminal equipment and mutual recognition of their conformity.
According to the following standards: ETSI EN 300 220-3; ETSI EN 301 489-1; ETSI EN 301 498-3.	

Oderzo, 2<sup>nd</sup> February 2005

Lauro Buoro  
(Managing Director)





# Declaration of Conformity

According to Directive 98/37/EEC, ANNEXE II, part A (CE declaration of conformity for machines)

The undersigned / Company

\_\_\_\_\_  
*(name or business name of person who has put the power operated sectional or up-and-over door into service)*

\_\_\_\_\_  
*(address)*

Declares under his/her sole responsibility that:

The automation : power operated sectional or up-and-over door

Serial number: : \_\_\_\_\_

Year of manufacture : \_\_\_\_\_

Location (address) : \_\_\_\_\_

**Satisfies the essential requirements of the following Directives:**

98/37/EC            Machine Directive  
89/336/EEC        Electromagnetic Compatibility Directive  
73/23/EEC         Low Voltage Directive  
95/5/EC            "R&TTE" Directive

And the provisions of the following harmonised standards:

EN 12445            "Industrial, commercial and garage doors and gates.  
Safety in use of power operated doors – Test methods"  
EN 12453            "Industrial, commercial and garage doors and gates.  
Safety in use of power operated doors – Requirements"

Name \_\_\_\_\_ Signature \_\_\_\_\_

Date \_\_\_\_\_ Location \_\_\_\_\_





## 7.3 Annexe 3. OPERATING GUIDE

This guide should be stored in an accessible location and made available to all users of the automation.

### 7.3.1 Safety regulations

- **Keep an eye on the moving door and keep at a safe distance until the door has completely opened or closed; do not cross the opening until the door has completely opened and stopped.**
- **Do not allow children to play near the door or with its controls.**
- **Keep the transmitter out of the reach of children.**
- **Stop using the automation system immediately if you notice anything abnormal (strange noise or jerky movements); failure to observe this warning may result in serious danger and accidents.**

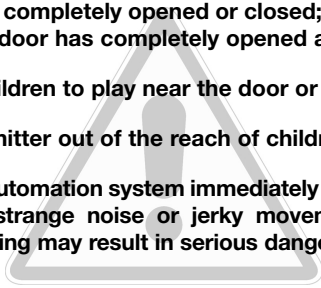

- **Do not touch any components while they are moving.**
- **Have periodic checks made according to the instructions provided in the maintenance schedule.**
- **Maintenance operations and repairs can only be performed by qualified technicians.**

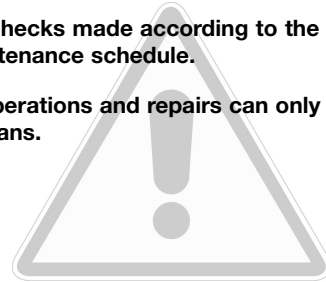

### 7.3.2 Door Control

#### With radio transmitter

The radio transmitter is ready for use and the four buttons have the following functions:

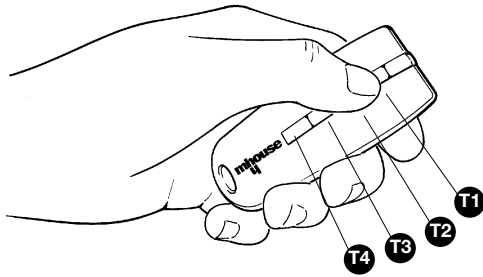

Figure 90

Function(*)	
T1 button	
T2 button	
T3 button	
T4 button	

(\*) This table must be prepared by the person who has programmed the system:

#### With pushbutton (incorporated)

The movement of the door can be controlled by operating the orange button directly **[A]**.

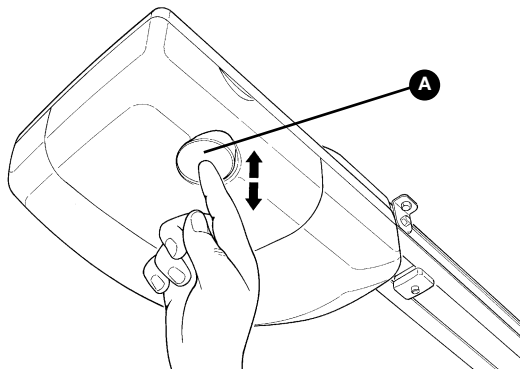

Figure 91

#### With selector switch (optional accessory)

With selector switch (optional accessory)

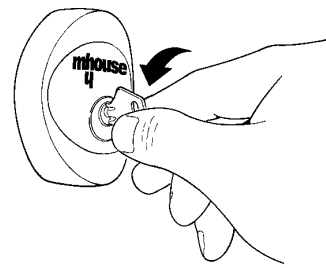

Figure 92

Action	Function
Rotated to the right: "OPEN"	(*)
Rotated to the left: "STOP"	It stops the movement of the sectional or up-and-over door

(\*) This item must be drafted by the person who has programmed the system:

#### Control with safety devices out of order

If the safety devices are out of order or malfunctioning, it is still possible to control the door.

**1** Operate the gate control device (remote control or key-operated selector switch). If the safety devices enable the operation, the door will open normally, otherwise: actuate the control again within 3 seconds and keep it actuated.

**2** After approximately 2s the gate will start moving in the "man present" mode, i.e. so long as the control is maintained the gate will keep moving; as soon as the control is released the door will stop.

If the safety devices are out of order the automation must be repaired as soon as possible.

### Gearmotor release

The gearmotor is equipped with a mechanical system which allows the door to be opened and closed manually (i.e. as if GD were not present). The manual operation must be resorted to in case of power failures or system malfunctions.

- 1 Pull the release cord until you hear the carriage being released.
- 2 At this point you can move the door manually
- 3 To restore the functionality of the automation system, move the door back in position until you hear the carriage being engaged.

The activation of the manual release may cause an uncontrollable movement of the door if the springs are weak or broken, or if the door is off-balance.

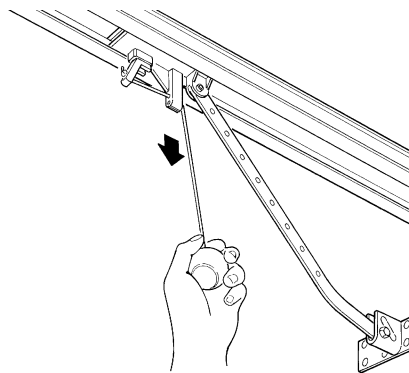

Figure 93

### 7.3.3 Maintenance Operations to Be Performed by the User

The operations that must be periodically performed by the user are listed below

- Periodically check the system, especially cables, springs and supports, for possible imbalance or signs of wear or damage. Do not use the automation system if repair or adjustment is necessary, in as much that a fault or an incorrectly balanced door could cause injury.

- Disconnect the power supply to the automation before you proceed to remove leaves and debris, to prevent anyone from activating the door

- Use a slightly damp cloth (not wet) to clean the surface of the devices. Do not use any substances containing alcohol, benzene, diluents or other flammable substances. The use of these substances could damage the devices, start fires or generate electric shocks.

### 7.3.4 Replacing the Remote Control Battery

If the range of the remote control is significantly diminished and the light emitted by the LED is feeble, the remote control battery is probably exhausted. The remote control houses two CR2016 type lithium batteries. To replace them proceed as follows:

- 1 Open the bottom by pulling it.

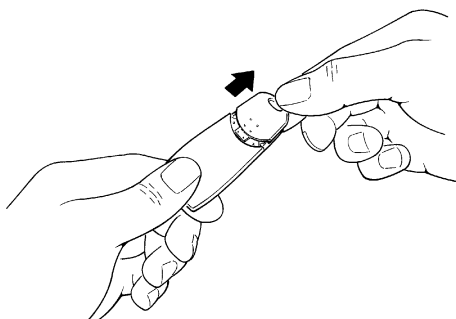

Figure 94

- 2 Insert a small pointed tool in the slit and prise the batteries out.

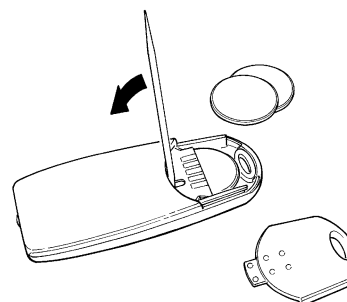

Figure 95

- 3 Insert the new battery, observing the polarity (the "+" symbol towards the bottom).

- 4 Close the bottom until it clicks.

**The batteries contain polluting substances: do not dispose of them together with other waste but use the methods established by local regulations.**

### 7.3.5 Lamp replacement

Before proceeding, disconnect GD from the power supply.

- 1 Aprire il coperchio svitando la vite [A] e premendo il bottone [B].

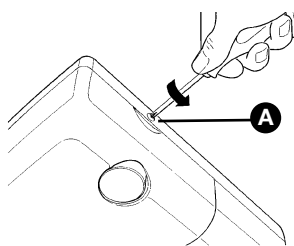

Figure 96

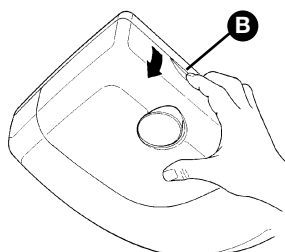

Figure 97

- 2 Push the lamp up and rotate to remove. Insert a new 12V / 21W lamp with BA15 socket.

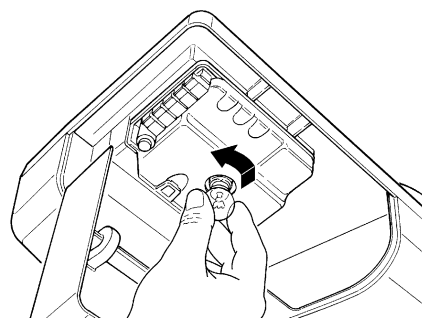

Figure 98



**Mhouse**

Via Pezza Alta, 13 - Z.I. Rustignè  
31046 Oderzo TV Italia  
Tel. +39 0422 20 21 09  
Fax +39 0422 85 25 82  
info@mhouse.biz  
[www.mhouse.biz](http://www.mhouse.biz)

